

PAKISTAN STANDARD

Polyvinyl chloride insulated cables of rated voltages up to and including 450/750 V

Part-2: Test methods



(All Rights Reserved)

**PAKISTAN STANDARDS AND QUALITY CONTROL AUTHORITY,
STANDARDS DEVELOPMENT CENTRE,
PSQCA Complex Street 7 A Block –3
Scheme –36 Gulistan –e- johar Karachi**

Polyvinyl chloride insulated cables of rated voltages up to and including 450/750 V

Part-2: Test methods

0. FOREWORD

- 0.1 This Pakistan Standard was adopted by the authority of the Board of Directors of Pakistan Standard and Quality Control Authority after the draft prepared by the Technical Committee for “**Electric Cables**” (TC-7)” had been approved and endorsed by the National Standards Committee on 27 June 2007.
- 0.2 This Pakistan Standard was adopted on the basis of IEC: 60227-2 since IEC Standard have been established in 1997, hence it is deemed necessary to adopt the International standard to keep abreast with the latest technology and as par with IEC standard.
- 0.3 This Pakistan Standard is an adoption of IEC: 60227-2-2007 Polyvinyl chloride insulated cables of rated voltages up to and including 450/750 V Part-2 Test methods,” and its use hereby acknowledged with thanks.
- 0.4 This standard is subject to periodical review in order to keep pace with the development in industry. Any suggestions for improvement shall be recorded and placed before the revising committee in due course.
- 0.5 This standard is intended chiefly to cover the technical provisions relating to this standard and it does not include all the necessary provisions of a Contract.

CONTENTS

FOREWORD	
1 General.....	
1.1 General requirements	
1.2 Applicable tests	
1.3 Classification of tests according to the frequency with which they are carried out	
1.4 Sampling	
1.5 Pre-conditioning.....	
1.6 Test temperature	
1.7 Test voltage.....	
1.8 Checking of the durability of colours and markings	
1.9 Measurement of insulation thickness.....	
1.10 Measurement of sheath thickness	
1.11 Measurement of overall dimensions and ovality	
2 Electrical tests	
2.1 Electrical resistance of conductors	
2.2 Voltage test carried out on completed cables.....	
2.3 Voltage test on cores	
2.4 Insulation resistance	
3 Tests of mechanical strength of completed flexible cables	
3.1 Flexing test.....	
3.2 Bending test.....	
3.3 Snatch test	
3.4 Test for separation of cores	
3.5 Static flexibility test	
3.6 Tensile strength of the central heart of lift cables.....	
Figure 1 – Flexing apparatus	
Figure 2 – Bending test apparatus	
Figure 3 – Static flexibility test	
Table 1 – Mass of weight and diameter of pulleys	

POLYVINYL CHLORIDE INSULATED CABLES OF RATED VOLTAGES UP TO AND INCLUDING 450/750 V –

Part 2: Test methods

1 General

1.1 General requirements

The methods of carrying out the tests specified in all parts of IEC 60227 are given in this part and the following publications:

IEC 60227-1:1993, *Polyvinyl chloride insulated cables of rated voltages up to and including 450/750 V – Part 1: General requirements*

IEC 60332-1:Tests on electric cables under fire conditions – Part 1: Test on a single vertical insulated cable

IEC 60811-1-1:1993, *Common test methods for insulating and sheathing materials of electrical cables – Part 1: Methods for general application – Section 1: Measurement of thickness and overall dimensions – Test for determining the mechanical properties*

1.2 Applicable tests

The tests applicable to the types of cables are given in the particular specifications (IEC 60227-3, IEC 60227-4, etc.).

1.3 Classification of tests according to the frequency with which they are carried out

The tests specified are type tests (symbol T) and/or sample tests (symbol S) as defined in 2.2 of IEC 60227-1.

The symbols T and S are used in the relevant tables of the particular specifications (IEC 60227-3, IEC 60227-4, etc.).

1.4 Sampling

If a marking is in relief in the insulation or sheath, the samples used for the tests shall be taken so as to include such marking.

For multicore cables, except for the test specified in 1.9, not more than three cores (of different colours, if applicable) shall be tested unless otherwise specified.

1.5 Pre-conditioning

All the tests shall be carried out not less than 16 h after the extrusion of the insulating or sheathing compounds.

1.6 Test temperature

Unless otherwise specified, tests shall be made at ambient temperature.

1.7 Test voltage

Unless otherwise specified, the test voltages shall be a.c. 49 Hz to 61 Hz of approximately sine-wave form, the ratio peak value/r.m.s. value being equal to $\sqrt{2}$ with a tolerance of $\pm 7\%$.

The values quoted are r.m.s. values.

1.8 Checking of the durability of colours and markings

Compliance with this requirement shall be checked by trying to remove the marking of the manufacturer's name or trade mark and the colours of cores or numerals by rubbing lightly ten times with a piece of cotton wool or cloth soaked in water.

1.9 Measurement of insulation thickness

1.9.1 Procedure

The thickness of insulation shall be measured in accordance with 8.1 of IEC 60811-1-1. One sample of cable shall be taken from each of three places, separated by at least 1 m.

Compliance shall be checked on each core of cables having up to five cores, and on any five cores of cables with more than five cores.

If withdrawal of the conductor is difficult, it shall be stretched in a tensile machine or the piece of core shall be loosened by stretching or some other suitable means that does not damage the insulation.

1.9.2 Evaluation of results

The mean of the 18 values (expressed in millimetres) obtained from the three pieces of insulation from each core shall be calculated to two decimal places and rounded off as given below, and this shall be taken as the mean value of the thickness of insulation.

If in the calculation the second decimal figure is 5 or more, the first decimal figure shall be raised to the next number, thus, for example, 1,74 shall be rounded off to 1,7 and 1,75 to 1,8.

The lowest of all values obtained shall be taken as the minimum thickness of insulation at any place.

This test may be combined with any other measurements of thickness, for instance those of 5.2.4 of IEC 60227-1.

1.10 Measurement of sheath thickness

1.10.1 Procedure

The thickness of sheath shall be measured in accordance with 8.2 of IEC 60811-1-1.

One sample of cable shall be taken from each of three places, separated by at least 1 m.

1.10.2 Evaluation of results

The mean of all the values (expressed in millimetres) obtained from the three pieces of sheath shall be calculated to two decimal places and rounded off as given below, and this shall be taken as the mean value of the thickness of sheath.

If in the calculation the second decimal figure is 5 or more, the first decimal figure shall be raised to the next number, thus, for example, 1,74 shall be rounded off to 1,7 and 1,75 to 1,8.

The lowest of all values obtained shall be taken as the minimum thickness of sheath at any place.

This test may be combined with any other measurements of thickness, for instance those of 5.5.4 of IEC 60227-1.

1.11 Measurement of overall dimensions and ovality

The three samples taken in accordance with 1.9 or 1.10 shall be used.

The measurement of the overall diameter of any circular cable and of the overall dimensions of flat cables with a major dimension not exceeding 15 mm shall be carried out in accordance with 8.3 of IEC 60811-1-1.

For the measurement of flat cables with a major dimension exceeding 15 mm, a micrometer, a profile projector or similar appliance shall be used.

The mean of the values obtained shall be taken as the mean overall dimension.

For checking the cable ovality of circular sheathed cables, two measurements shall be made at the same cross-section of the cable.

2 Electrical tests

2.1 Electrical resistance of conductors

In order to check the electrical resistance of conductors, the resistance of each conductor shall be measured from a sample of cable of at least 1 m in length, and the length of each sample shall be measured.

If necessary, a correction to 20 °C and to a length of 1 km shall be obtained by the formula:

$$R_{20} = R_t \frac{254,5}{234,5 + t} \cdot \frac{1\ 000}{L}$$

where

t is the temperature of the sample at the moment of measurement, in degrees Celsius

R_{20} is the resistance at 20 °C, in ohm/kilometre

R_t is the resistance of L metres of cable at t °C in ohms

L is the length of the sample of cable, in metres (length of the complete sample and not of the individual cores or wires)

2.2 Voltage test carried out on completed cables

A sample of cable, as delivered, shall be immersed in water if the cable has no metallic layer. The length of the sample, the temperature of the water and the duration of immersion are given in table 3 of IEC 60227-1.

A voltage shall be applied in turn between each conductor and all the others connected together and to the metallic layer, if any, or to the water, then between all conductors connected together and the metallic layer or water.

The voltage and the duration of its application are given for each case in table 3 of IEC 60227-1.

2.3 Voltage test on cores

The test applies to sheathed cables and to flat non-sheathed cords but not to flat tinsel cords.

The test shall be made on a sample of cable of 5 m length. The sheath and any other covering or filling shall be removed without damaging the cores.

In the case of a flat non-sheathed cord, a short cut shall be made in the insulation between the cores, and the cores shall be separated by hand for a length of 2 m. The voltage and the duration of its application are given for each case in table 3 of IEC 60227-1.

The cores shall be immersed in water as specified in table 3 of IEC 60227-1, and a voltage shall be applied between the conductors and the water.

The voltage and the duration of its application are given for each case in table 3 of IEC 60227-1.

2.4 Insulation resistance

This test applies to all cables. It shall be made on the core samples, 5 m in length, previously submitted to the test described in 2.3 or, if this is not applicable, to the test described in 2.2.

The sample shall be immersed in water previously heated to the specified temperature, a length of about 0,25 m at each end of the sample being kept above the water.

The length of the samples, the temperature of the water and the duration of immersion are given in table 3 of IEC 60227-1.

A d.c. voltage of between 80 V and 500 V shall then be applied between the conductor and the water.

The insulation resistance shall be measured 1 min after application of the voltage and this value shall be related to 1 km.

None of the resulting values shall be below the minimum insulation resistance value prescribed in the particular specifications (IEC 60227-3, IEC 60227-4, etc.).

The values of the insulation resistance specified in the particular specifications (IEC 60227-3, IEC 60227-4, etc.) are based on a volume resistivity of $1 \times 10^8 \Omega \cdot \text{m}$; they have been calculated from the formula:

$$R = 0,0367 \log_{10} \frac{D}{d}$$

where:

R is the insulation resistance, in megohm kilometre

D is the nominal outer diameter of the insulation

d is the diameter of the circumscribed circle of the conductor or, for tinsel cords, the nominal inner diameter of the insulation

3 Tests of mechanical strength of completed flexible cables

3.1 Flexing test

3.1.1 General

The requirements are given in 5.6.3.1 of IEC 60227-1.

This test does not apply to tinsel cords, nor to single-core cables with flexible conductors for fixed wiring, nor to multi-core flexible cables having cores of nominal cross sectional area greater than 2,5 mm².

3.1.2 Apparatus

This test shall be carried out by means of the apparatus shown in figure 1. This apparatus consists of a carrier C, a driving system for the carrier and four pulleys for each sample of cable to be tested. The carrier C supports two pulleys A and B, which are of the same diameter. The two fixed pulleys, at either end of the apparatus, may be of a different diameter from pulleys A and B, but all four pulleys shall be so arranged that the sample is horizontal between them. The carrier makes cycles (forward and backward movements) over a distance of 1 m at an approximately constant speed of 0,33 m/s between each reversal of the direction of movement.

The pulleys shall be made of metal and have a semi-circular shaped groove for circular cables and a flat groove for flat cables. The restraining clamps D shall be fixed so that the pull is always applied by the weight from which the carrier is moving away. The distance from one restraining clamp to its support, while the other clamp is resting on its support, shall be of 5 cm maximum.

The driving system shall be such that the carrier turns smoothly and without jerks when it reverses from one direction to another.

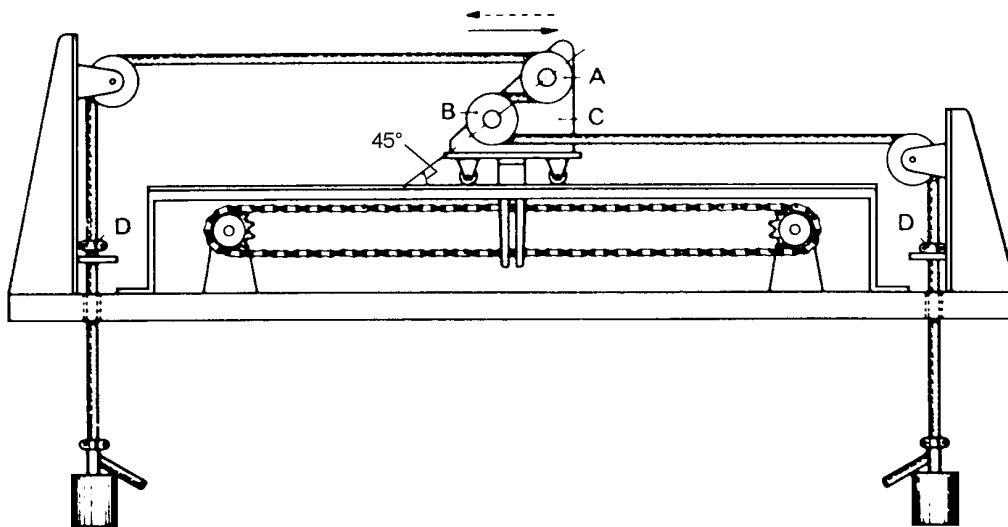

Figure 1 – Flexing apparatus

3.1.3 Sample preparation

A sample of flexible cable about 5 m long shall be stretched over the pulleys, as shown in figure 1, each end being loaded with a weight. The mass of this weight and the diameter of pulleys A and B are given in table 1.

Table 1 – Mass of weight and diameter of pulleys

Types of flexible cables	Number of cores ²⁾	Nominal cross-sectional area mm ²	Mass of weight kg	Diameter of pulleys ¹⁾ mm
Flat non-sheathed cord	2	0,5	0,5	60
		0,75	1,0	60
Light polyvinyl chloride sheathed cable Ordinary polyvinyl chloride sheathed cable	2	0,5	0,5	60
		0,75	1,0	80
		1	1,0	80
		1,5	1,0	80
		2,5	1,5	120
	3	0,5	0,5	80
		0,75	1,0	80
		1	1,0	80
		1,5	1,0	80
	4	0,5	0,5	80
		0,75	1,0	80
		1	1,0	80
1,5		1,5	120	
Light polyvinyl chloride sheathed cable Ordinary polyvinyl chloride sheathed cable	5	0,5	1,0	80
		0,75	1,0	80
		1	1,0	120
		1,5	1,5	120
		2,5	2,0	120
Ordinary polyvinyl chloride sheathed cable	6	0,5	1,0	120
		0,75	1,5	120
		1	1,5	120
		1,5	2,0	120
		2,5	3,5	160
	7	0,5	1,0	120
		0,75	1,5	120
		1	1,5	120
		1,5	2,0	160
		2,5	3,5	160
	12	0,5	1,5	120
		0,75	2,0	160
		1	3,0	160
		1,5	4,0	160
		2,5	7,0	200
	18	0,5	2,0	160
		0,75	3,0	160
		1	4,0	160
		1,5	6,0	200
		2,5	7,5	200
<p>¹⁾ Diameter measured at the lowest point of the groove.</p> <p>²⁾ Cables with numbers of cores between 7 and 18, but not specified in this table, are non-preferred cable types. They may be tested using the mass of weight and the pulley diameter for the same conductor size at the next higher specified number of cores.</p>				

3.1.4 Current loading of cores

For the current loading, either a low voltage or a voltage about 230/400 V may be used.

During the flexing test, the cable sample shall be loaded as follows:

- two and three core cables: all cores to be loaded with $1 \text{ A/mm}^2 \begin{smallmatrix} +10 \\ 0 \end{smallmatrix} \%$;
- four and five core cables: three cores to be loaded with $1 \text{ A/mm}^2 \begin{smallmatrix} +10 \\ 0 \end{smallmatrix} \%$ or all cores to be loaded with $\sqrt{3/n} \text{ A/mm}^2 \begin{smallmatrix} +10 \\ 0 \end{smallmatrix} \%$, where n is the number of cores.

Cables having more than five cores shall not be loaded. On cores which are not loaded, a signal current shall be applied.

3.1.5 Voltage between cores

For two-core cables the voltage between the conductors shall be about 230 V a.c. For all other cables having three or more cores, a three-phase a.c. voltage of about 400 V shall be applied to three conductors, any additional conductors being connected to the neutral. Three adjacent cores shall be tested. In case of a two-layer construction, they shall be taken from the outer layer. This also applies when a low voltage current loading system is used.

3.1.6 Fault detection (construction of the flexing apparatus)

The flexing apparatus shall be constructed so that it will detect and stop if the following occurs during the flexing test:

- interruption of the current;
- short circuit between the conductors;
- short circuit between the test sample and the pulleys (flexing apparatus).

3.2 Bending test

The requirements are given in 5.6.3.2 of IEC 60227-1.

A sample of cord of appropriate length shall be fixed in the apparatus as shown in figure 2, and loaded with a weight having a mass of 0,5 kg. A current of about 0,1 A shall be passed through the conductors.

The sample shall be bent backwards and forwards in a direction perpendicular to the plane of the axes of the conductors, the two extreme positions making an angle of 90° on both sides of the vertical.

A flexing is a movement through 180° . The rate of flexing is 60 per minute.

If the sample does not comply with the test, this shall be repeated with two additional samples, both of which shall then comply with the repeated test.

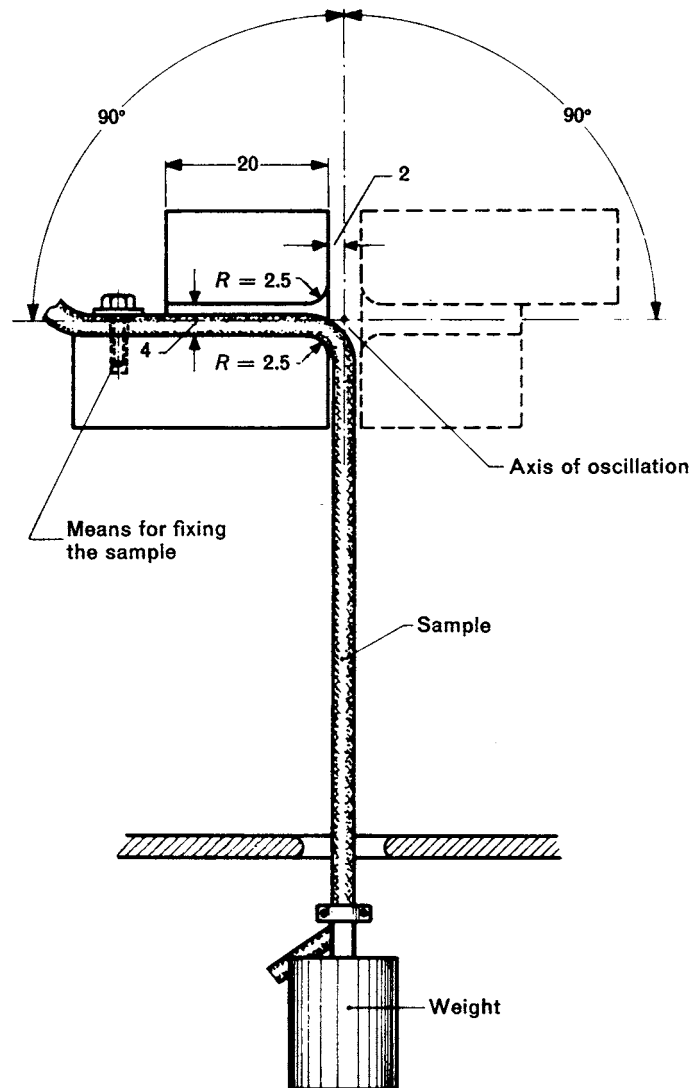

267/79

*Dimensions in millimetres***Figure 2 – Bending test apparatus****3.3 Snatch test**

The requirements are given in 5.6.3.3 of IEC 60227-1.

A sample of cord of appropriate length shall be attached by one end to a rigid support and a weight having a mass of 0,5 kg shall be secured to the sample 0,5 m below the point of attachment. A current of about 0,1 A shall be passed through the conductors. The weight shall be raised to the point of attachment and then dropped, five times.

3.4 Test for separation of cores

The requirements are given in 5.6.3.4 of IEC 60227-1.

This test applies to flat non-sheathed cords.

On a short sample of cord, a cut shall be made in the insulation between the cores. The force necessary to separate them at a speed of 5 mm/s shall be measured by means of a tensile machine.

3.5 Static flexibility test

The requirements are given in the specific parts of IEC 60227.

This test shall be applied to cables with conductor cross-sectional areas up to and including 2,5 mm².

Before the test, the cable shall be conditioned at (20 ± 5) °C for 24 h in a vertical position.

A sample with a length of $(3 \pm 0,05)$ m shall be tested in an apparatus similar to that shown in figure 3. Two clamps, A and B, shall be located at a height of at least 1,5 m above ground level.

Clamp A shall be fixed and clamp B shall move horizontally at the level of clamp A.

The ends of the sample shall be clamped vertically (and remain vertical during the test), one end in clamp A, the other in the movable clamp B which shall be at a distance $l = 0,20$ m from clamp A. The cable takes roughly the shape indicated in figure 3 by the dotted lines.

The movable clamp B shall then be moved away from the fixed clamp A until the loop formed by the cable takes the shape, indicated in figure 3 by the continuous outline, of the U enclosed wholly between two plumb lines through the clamps and set up tangentially to the external generatrix of the cable. This test shall be done twice, the cable being turned in the clamp, after the first test, through 180°.

The mean of the two values of l' shall be measured between the two plumb lines.

If the results of the test are unfavourable, the sample shall be preconditioned by winding it two times on and off a reel with a barrel diameter of approximately 20 times the smallest dimension of the cable; after one winding the sample shall be turned through 180°. After this preconditioning, the sample shall be subjected to the test described above and shall meet the specified requirements.

3.6 Tensile strength of the central heart of lift cables

The requirements are given in the specific parts of IEC 60227.

A sample of the completed cable, 1 m long, shall be weighed.

After removal of all covering and cores over a distance of about 0,20 m at both ends of the sample, the central heart including the strain-bearing centre shall be subjected to a tensile force, corresponding to the mass of 300 m of cable.

The force shall be applied for 1 min.

A freely hanging weight or a suitable mechanical strength testing machine capable of applying a constant force may be used.

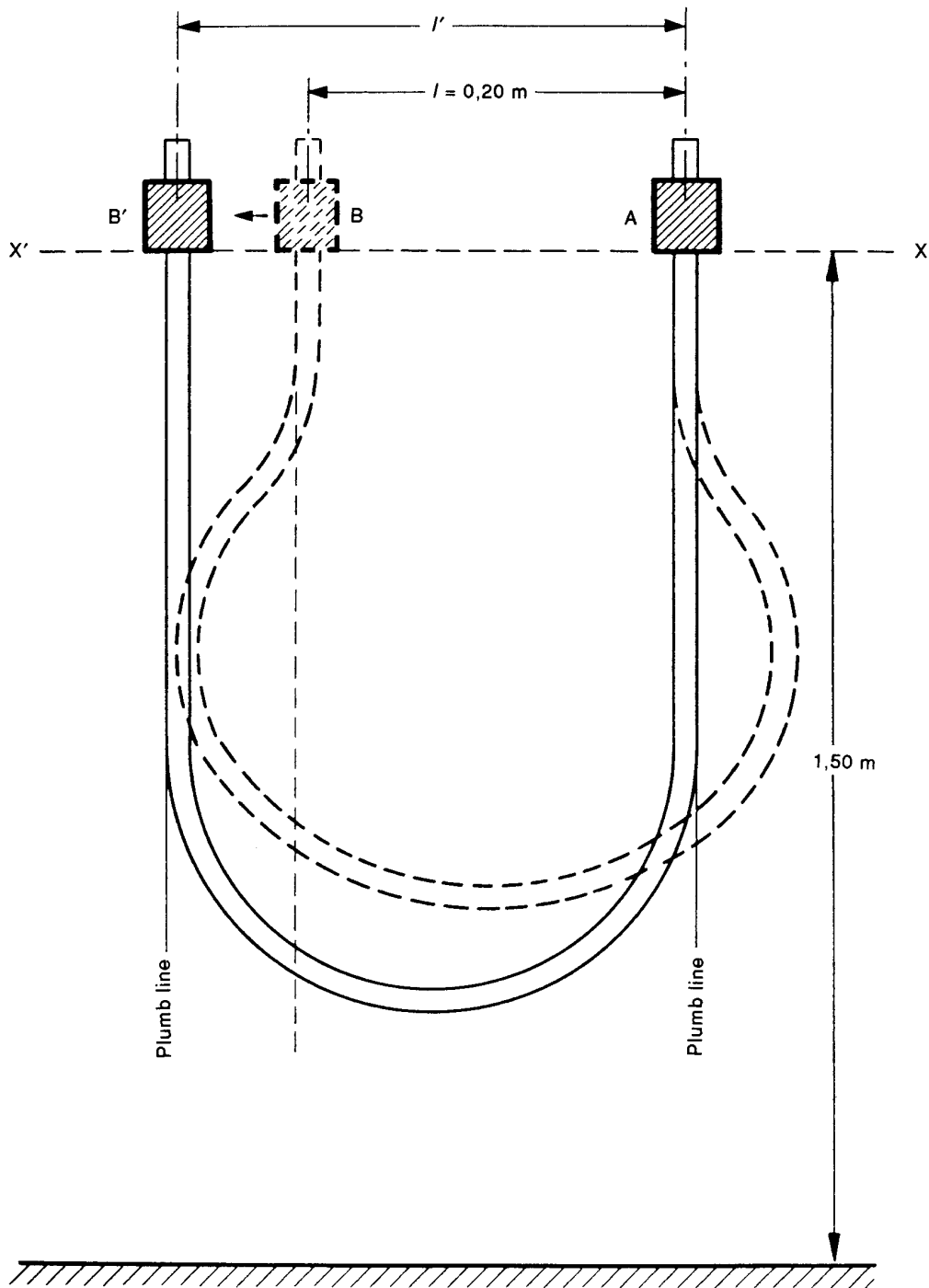

Figure 3 – Static flexibility test