

PS: IEC 62040-3 /2013

ICS No. 29.200

PAKISTAN STANDARD

UNINTERRUPTIBLE POWER SYSTEMS (UPS)

**PART 3: METHOD OF SPECIFYING THE PERFORMANCE
AND TEST REQUIREMENTS**



(All Rights Reserved)

**PAKISTAN STANDARDS AND QUALITY CONTROL AUTHORITY,
STANDARDS DEVELOPMENT CENTRE,
PSQCA COMPLEX, PLOT NO. ST – 7/A, BLOCK NO. 3,
SCHEME – 36, GULISTAN-E-JAUHAR,
KARACHI**

PS: IEC 62040-3/2013

PAKISTAN STANDARD SPECIFICATION
FOR
UNINTERRUPTIBLE POWER SYSTEMS (UPS) –
PART 3: METHOD OF SPECIFYING THE PERFORMANCE AND TEST
REQUIREMENTS

0. FOREWORD

- 0.1 This Pakistan Standard was adopted by the authority of the Board of Directors of Pakistan Standards and Quality Control Authority (PSQCA), after the draft prepared by the Technical Committee for "Power electronics. Industrial-process measurement and control (ESTC-3)" had been approved and endorsed by the National Standards Committee for Electronics on 21-03-2013.
- 0.2 This Standard is an adoption of IEC Publication IEC 62040-3-2011: Uninterruptible power systems (UPS) – Part 3: Method of specifying the performance and test requirements.
- 0.3 This Standard has been prepared and finalized after taking into consideration the views and suggestions put forwarded by the representative section of technologists, manufacturers and utilizing agencies.
- 0.4 This Standard is subject to periodical review in order to keep pace with the changing requirements and latest development in the industry. Any suggestion for improvement will be recorded and placed before the revising committee in due course.
- 0.5 This Standard covers the technical provisions and it does not purport to include all the necessary provisions of a contract.
-

CONTENTS

FOREWORD.....	
1 Scope.....	
2 Normative references	
3 Terms and definitions	
3.1 Systems and components.....	
3.2 Performance of systems and components	
3.3 Specified values- General	
3.4 Input values.....	
3.5 Output values	
4 Environmental conditions.....	
4.1 Introduction	
4.2 Normal conditions	
4.2.1 Operation	
4.2.2 Storage and transportation	
4.3 Unusual conditions	
4.3.1 Introduction	
4.3.2 Operation	
4.3.3 Storage and transportation	
5 Electrical conditions, performance and declared values.....	
5.1 General.....	
5.1.1 UPS configuration	
5.1.2 Markings and instructions.....	
5.1.3 Safety.....	
5.1.4 Electromagnetic compatibility	
5.2 UPS input specification	
5.2.1 Conditions for normal mode operation	
5.2.2 Characteristics to be declared by the manufacturer	
5.2.3 Characteristics and conditions to be identified by the purchaser	
5.3 UPS output specification	
5.3.1 Conditions for the UPS to supply a load.....	
5.3.2 Characteristics to be declared by the manufacturer	
5.3.3 Characteristics and conditions to be identified by the purchaser	
5.3.4 Performance classification.....	
5.4 Stored energy specification	
5.4.1 General	
5.4.2 Battery	
5.5 UPS switch specification	
5.6 Communication circuits	
6 UPS tests	
6.1 Summary.....	
6.1.1 Venue, instrumentation and load	
6.1.2 Routine test.....	
6.1.3 Site test.....	
6.1.4 Witness test.....	
6.1.5 Type test	
6.1.6 Schedule of tests.....	

6.2	Routine test procedure	
6.2.1	Environmental	
6.2.2	Electrical	
6.3	Site test procedure	
6.4	Type test procedure (electrical)	
6.4.1	Input – a.c. supply compatibility	
6.4.2	Output – Linear load	
6.4.3	Output – Non-linear load	
6.4.4	Stored and restored energy	
6.5	Type test procedure (environmental)	
6.5.1	Environmental and transportation test methods	
6.5.2	Transportation	
6.5.3	Storage	
6.5.4	Operation	
6.5.5	Acoustic noise	
6.6	UPS functional unit tests (where not tested as a complete UPS)	
6.6.1	UPS rectifier tests	
6.6.2	UPS inverter tests	
6.6.3	UPS switch tests	
6.6.4	Stored energy / battery tests	
Annex A	(informative) Uninterruptible power system (UPS) configurations	
Annex B	(informative) Topologies – Uninterruptible power system (UPS)	
Annex C	(informative) UPS switch applications	
Annex D	(informative) Purchaser specification guidelines	
Annex E	(normative) Reference non-linear load	
Annex F	(informative) Information on backfeed protection	
Annex G	(normative) Input mains failure – Test method	
Annex H	(informative) Dynamic output performance – Measurement techniques	
Annex I	(informative) UPS Efficiency values	
Annex J	(normative) UPS efficiency – Methods of measurement	
Annex K	(informative) UPS functional availability	
	Bibliography	
	Figure 1 – Typical “non-sinusoidal” output voltage waveform	
	Figure 2 – Curve 1 – Dynamic output performance classification 1	
	Figure 3 – Curve 2 – Dynamic output performance classification 2	
	Figure 4 – Curve 3 – Dynamic output performance classification 3	
	Figure 5 – Linear load test method	
	Figure 6 – Reference non-linear load test method	
	Figure A.1 – Single UPS – Basic	
	Figure A.2 – Single UPS with bypass	
	Figure A.3 – Parallel UPS with common bypass	
	Figure A.4 – Parallel UPS with distributed bypass	
	Figure A.5 – Stand-by redundant UPS	
	Figure A.6 – Dual bus UPS	

Figure A.7 – Stand-by redundant dual bus UPS	
Figure B.1 – Double conversion topology	
Figure B.2 – Line-interactive topology	
Figure B.3 – Stand-by topology	
Figure C.1 – UPS interrupter	
Figure C.2 – UPS interrupters in parallel UPS application	
Figure C.3 – UPS interrupters in split load application	
Figure C.4 – Bypass transfer switch	
Figure C.5 – Isolation of bypass transfer switch	
Figure C.6 – Isolation of interrupters	
Figure C.7 – Isolation switches with interrupter function	
Figure C.8 – Internal maintenance bypass switch	
Figure C.9 – External maintenance bypass switch	
Figure C.10 – Tie switch in dual bus application	
Figure C.11 – Tie switches in triple bus application	
Figure C.12 – Multiple function bypass, interrupter and isolation switch	
Figure E.1 – Reference non-linear load	
Figure G.1 – Connection of test circuit	
Figure H.1 – Example: instantaneous voltage variation in compliance with curve 1 of Figure 2	
Figure I.1 – Example of VFI-S stand-by allowance	
Figure I.2 – Example of VFI-S duty allowance	
Figure I.3 – Example of VFI-S stand-by and duty allowance	
Figure I.4 – Example of VFD duty allowance calculation	
Figure K.1 – Reliability % over time	
Figure K.2 – Maintainability % over time	
Table 1 – Power derating factors for use at altitudes above 1 000 m	
Table 2 – Compatibility levels for individual harmonic voltages in low voltage networks	
Table 3 – UPS test schedule	
Table 4 – Free fall testing	
Table D.1 – UPS technical data – Manufacturer’s declaration	
Table I.1 – Efficiency for UPS rated from 0,3 kVA to less than 10,0 kVA with classification “VFI – S...”	
Table I.2 – Efficiency for UPS rated from 0,3 kVA to less than 10,0 kVA with classification VI and VFI, except “VFI – S...”	
Table I.3 – Efficiency for UPS rated from 0,3 kVA to less than 10,0 kVA with classification VFD	
Table I.4 – Efficiency for UPS rated from 10,0 kVA (inclusive) and above with classification “VFI – S...”	
Table I.5 – Efficiency for UPS rated from 10,0 kVA (inclusive) and above with classification VI and VFI, except “VFI – S...”	
Table I.6 – Efficiency for UPS rated from 10,0 kVA (inclusive) and above with classification VFD	
Table I.7 – UPS efficiency allowances for input or output isolation transformer	

Table I.8 – UPS efficiency allowances for input harmonic current filtering

Table K.1 – Reliability integrity levels for UPS

only for research purposes
not for sale
copyright www.psqca.com.pk

UNINTERRUPTIBLE POWER SYSTEMS (UPS) –

Part 3: Method of specifying the performance and test requirements

1 Scope

This International Standard applies to movable, stationary and fixed electronic **uninterruptible power systems** (UPS) that deliver single or three-phase fixed frequency a.c. output voltage not exceeding 1 000 V a.c. and that incorporate an **energy storage system**, generally connected through a d.c. link.

This standard is intended to specify performance and test requirements of a complete UPS and not of individual **UPS functional units**. The individual UPS functional units are dealt with in IEC publications referred to in the bibliography that apply so far that they are not in contradiction with this standard.

The primary function of the UPS covered by this standard is to ensure continuity of an a.c. power source. The UPS may also serve to improve the quality of the power source by keeping it within specified characteristics. UPS have been developed over a wide range of power, from less than hundred watts to several megawatts, to meet requirements for availability and quality of power to a variety of loads. Refer to Annexes A and B for information on typical UPS configurations and topologies.

This standard also covers UPS test and performance when power switches form integral part of a UPS and are associated with its output. Included are interrupters, bypass switches, isolating switches and tie switches. These switches interact with other functional units of the UPS to maintain **continuity of load power**.

This standard does not cover

- conventional a.c. input and output distribution boards or d.c. boards and their associated switches (e.g. switches for batteries, rectifier output or inverter input);
- stand-alone static transfer systems covered by IEC 62310-3;
- systems wherein the output voltage is derived from a rotating machine.

NOTE 1 This standard recognises that power availability to information technology (IT) equipment represents a major UPS application. The UPS output characteristics specified in this standard are therefore also aimed at ensuring compatibility with the requirements of IT equipment. This, subject any limitation stated in the manufacturer's declaration, includes requirements for steady state and transient voltage variation as well as for the supply of both linear and non-linear load characteristics of IT equipment.

NOTE 2 Test loads specified in this standard simulate both linear and non-linear load characteristics. Their use is prescribed with the objective of verifying design and performance, as declared by the manufacturer, and also of minimising any complexity and energy consumption during the tests.

NOTE 3 This standard is aimed at 50 Hz and 60 Hz applications but does not exclude other frequency applications within the domain of IEC 60196. This is subject to an agreement between manufacturer and purchase in respect to any particular requirements arising.

NOTE 4 Single phase and three-phase voltage UPS covered by this standard include without limitation UPS supplying single-phase, two-wire; single-phase, three-wire; two-phase, three-wire, three-phase, three-wire and three-phase, four-wire loads.

2 Normative references

The following referenced documents are indispensable for the application of this document. For dated references, only the edition cited applies. For undated references, the latest edition of the referenced document (including any amendments) applies.

IEC 60038, *IEC standard voltages*

IEC 60068-2-1, *Environmental testing - Part 2-1: Tests – Test A: Cold*

IEC 60068-2-2, *Environmental testing – Part 2-2: Tests – Test B: Dry heat*

IEC 60068-2-27, *Environmental testing – Part 2-27: Tests – Test Ea and guidance: Shock*

IEC 60068-2-31:2008, *Environmental testing – Part 2-31: Tests – Test Ec: Rough handling shocks, primarily for equipment-type specimens*

IEC 60068-2-78, *Environmental testing – Part 2-78: Tests – Test Cab: Damp heat, steady state*

IEC 60146-1-1:2009, *Semiconductor converters – General requirements and line commutated converters – Part 1-1: Specification of basic requirements*

IEC 60146-2:1999, *Semiconductor converters – Part 2: Self-commutated semiconductor converters including direct d.c. converters*

IEC 60196, *IEC standard frequencies*

IEC 60364-1, *Low-voltage electrical installations – Part 1: Fundamental principles, assessment of general characteristics, definitions*

IEC 60364-5-52, *Low-voltage electrical installations – Part 5-52: Selection and erection of electrical equipment – Wiring systems*

IEC 60947-3, *Low-voltage switchgear and controlgear – Part 3: Switches, disconnectors, switch-disconnectors and fuse-combination units*

IEC 60947-6-1, *Low-voltage switchgear and controlgear – Part 6-1: Multiple function equipment – Transfer switching equipment*

IEC 60950-1, *Information technology equipment – Safety – Part 1: General requirements*

IEC 60990, *Methods of measurement of touch current and protective conductor current*

IEC 61000-2-2:2002, *Electromagnetic compatibility (EMC) – Part 2-2: Environment – Compatibility levels for low-frequency conducted disturbances and signalling in public low-voltage power supply systems*

IEC 61000-3-2, *Electromagnetic compatibility (EMC) – Part 3-2: Limits – Limits for harmonic current emissions (equipment input current ≤ 16 A per phase)*

IEC/TS 61000-3-4, *Electromagnetic compatibility (EMC) – Part 3-4: Limits – Limitation of emission of harmonic currents in low-voltage power supply systems for equipment with rated current greater than 16 A*

IEC 61000-3-12, *Electromagnetic compatibility (EMC) – Part 3-12: Limits – Limits for harmonic currents produced by equipment connected to public low-voltage systems with input current > 16 A and ≤ 75 A per phase*

IEC 61000-4-30, *Electromagnetic compatibility (EMC) – Part 4-30: Testing and measurement techniques – Power quality measurement methods*

IEC 61672-1, *Electroacoustics – Sound level meters – Part 2: Pattern evaluation tests*

IEC 62040-1:2008, *Uninterruptible power systems (UPS) – Part 1: General and safety requirements for UPS*

IEC 62040-2, *Uninterruptible power systems (UPS) – Part 2: Electromagnetic compatibility (EMC) requirements*

IEC 62310-3:2008, *Static transfer systems (STS) – Part 3: Method for specifying performance and test requirements*

ISO 7779:2010, *Acoustics – Measurement of airborne noise emitted by information technology and telecommunications equipment*

3 Terms and definitions

For the purposes of this document, the following terms and definitions apply.

NOTE In this standard, IEC 60050 definitions are referenced wherever possible, particularly those of IEC 60050(551).

When an existing IEC 60050 definition needs amplification or additional information, this is indicated by adding the word "modified" after the IEC 60050 reference.

3.1 Systems and components

3.1.1

uninterruptible power system

UPS

combination of convertors, switches and energy storage devices (such as batteries), constituting a power system for maintaining **continuity of load power** in case of input power failure

NOTE Input power failure occurs when voltage and frequency are outside rated steady-state and transient tolerance bands or when distortion or interruptions are outside the limits specified for the **UPS**.

3.1.2

(electronic) (power) converter or convertor

an operative unit for electronic power conversion, comprising one or more electronic valve devices, transformers and filters if necessary and auxiliaries if any

NOTE In English, the two spellings "converter" and "convertor" are in use, and both are correct.

[IEC 60050-551:1998, 551-12-01]

3.1.3

UPS functional unit

functional unit, for example, a UPS rectifier, a UPS inverter or a UPS switch

3.1.4

UPS rectifier

electronic converter for rectification

[IEC 60050-551:1998, 551-12-07, modified]

3.1.5

UPS inverter

electronic converter for inversion

[IEC 60050-551:1998, 551-12-10, modified]

3.1.6

energy storage system

system consisting of single or multiple devices and designed to provide power to the UPS inverter for the required stored energy time

NOTE Notwithstanding challenges with respect to recharge, examples of energy storage systems include but are not limited to battery, double-layer capacitor ("super" or "ultra" capacitor), flywheel and fuel-cell systems.

3.1.7

d.c. link

direct current power interconnection between the rectifier or rectifier/charger and the inverter functional unit

NOTE 1 The voltage of the energy storage system may differ from that of the d.c. link.

NOTE 2 The d.c. link may include converters.

3.1.8

battery

set of electrochemical cells of the same type so connected as to act together

[IEC 60050-151:2001, 151-12-11, modified]

3.1.9

secondary battery (of electrochemical cells)

composite system in which electric energy produces chemical reactions or, conversely, in which the energy produced by chemical reactions is mainly delivered as electric energy

[IEC 60050-111:1996, 111-15-10]

NOTE 1 A valve regulated secondary battery consists of cells which are closed but have a valve which allows the escape of gas if the internal pressure exceeds a predetermined value. Valve regulated lead-acid cells are abbreviated as VRLA cells [IEC 60050-482:2004, 482-05-15, modified].

NOTE 2 A vented secondary battery consists of cells having a cover provided with an opening through which products of electrolysis and evaporation are allowed to escape freely, or through a venting system, from the cell to the atmosphere [IEC 60050-482:2004, 482-05-14, modified].

3.1.10

flywheel storage system

mechanical energy storage system wherein stored kinetic energy can be converted to d.c. power during stored energy mode of operation

3.1.11

battery charger

device for changing alternating current power to direct current power for the purpose of charging a battery

3.1.12**UPS switch**

controllable switch used in accordance with applicable requirements for load power continuity to interconnect or isolate power ports of UPS units, bypass or load

NOTE 1 Annex C details UPS switch applications.

NOTE 2 Examples of ports include a group of terminals and sockets.

3.1.13**transfer switch**

UPS switch used to transfer power from one source to another

NOTE **Transfer** represents the act of switching the supply path to the load from one source to another.

3.1.14**electronic (power) switch**

UPS switch comprising at least one controllable valve device

[IEC 60050-551:1998, 551-13-01, modified]

NOTE A static bypass switch is an example of an electronic (power) switch.

3.1.15**mechanical (power) switch**

UPS switch with mechanically separable contacts

3.1.16**hybrid (power) switch**

UPS switch with mechanically separable contacts in combination with at least one controlled electronic valve device

3.1.17**self-commutated electronic switch**

electronic switch where the commutating voltage is supplied by components within the electronic switch

3.1.18**line-commutated electronic switch**

electronic switch where the commutating voltage is supplied by the line

3.1.19**interrupter**

UPS switch which is capable of making, carrying and breaking currents under normal circuit conditions, making and carrying currents for a specified time and breaking currents under specified unusual circuit conditions

3.1.20**isolation switch**

mechanical UPS switch that provides in the open position an isolating distance and that may be capable of making, carrying and breaking currents in accordance with UPS operational requirements

NOTE Resettable circuit-breakers and manual disconnectors are examples of isolation switches.

3.1.21**tie switch**

UPS switch which can connect two or more a.c. busbars together

3.1.22**maintenance bypass switch**

UPS switch designed to isolate a UPS, or part thereof, from the load and to maintain **continuity of load power** via an alternative path during maintenance activities

3.1.23**a.c. input power**

primary or stand-by power supplied to UPS and bypass circuits (maintenance bypass included)

3.1.24**bypass**

power path alternative to the a.c. converter

3.1.25**maintenance bypass (path)**

alternative power path provided to maintain **continuity of load power** during maintenance activities

3.1.26**static bypass (electronic bypass)**

power path (primary or stand-by) alternative to the indirect a.c. converter where control is via an electronic power switch, for example transistors, thyristors, triacs or other semiconductor device or devices

3.1.27**UPS unit**

complete UPS consisting of at least one of each of the following functional units: UPS inverter, UPS rectifier and battery, or other energy storage means

NOTE A UPS unit may operate with other UPS units to form a parallel or redundant UPS.

3.1.28**single UPS**

UPS comprising only one UPS unit

3.1.29**parallel UPS**

UPS comprising two or more UPS units operating in parallel

3.1.30**redundant system**

addition of functional units or groups of functional units in a system to enhance the **continuity of load power**

3.1.31**stand-by redundant UPS**

UPS in which one or more UPS are held in reserve until the operating UPS unit fails

3.1.32**parallel redundant UPS**

UPS with a number of paralleled load sharing UPS units which, upon failure of one or more UPS units, can take over full load with the remainders

3.2 Performance of systems and components

3.2.1

primary power

external electrical power source usually the public mains supply or other equivalent source such as user's own generation

3.2.2

stand-by power

external electrical power source intended to replace primary power in the event of primary power failure

3.2.3

backfeed

condition in which a voltage or energy available within the **UPS** is fed back to any of the input terminals, either directly or by a leakage path while operating in the **stored energy mode** and while **a.c. input power is not available**

3.2.4

linear load

load where the current drawn from the supply is defined by the relationship:

$$I = U/Z$$

where

I is the load current;

U is the supply voltage

Z is the constant load impedance

NOTE Application of a linear load to a sinusoidal voltage results in a sinusoidal current.

3.2.5

non-linear load

load where the parameter Z (load impedance) is no longer a constant but is a variable dependent on other parameters, such as voltage or time

3.2.6

power failure

any variation in power supply which can cause unacceptable performance of the load equipment

3.2.7

continuity of load power

voltage and frequency within rated steady-state and transient tolerance bands and with distortion and power interruptions within the limits specified for the load

3.2.8

battery ripple current

superimposed effective (r.m.s.) alternating component of the battery current

3.2.9

normal mode of UPS operation

stable mode of operation that the UPS attains under the following conditions:

- a) a.c. input supply is within required tolerances and supplies the UPS;
- b) the **energy storage system** remains charged or is under recharge;

- c) the load is within the specified rating of the UPS;
- d) the bypass is available and within specified tolerances (if applicable)

3.2.10

stored energy mode of UPS operation

stable mode of operation that the UPS attains under the following conditions:

- a) a.c. input power is disconnected or is out of required tolerance;
- b) all power is derived from the energy storage system;
- c) the load is within the specified rating of the UPS

3.2.11

bypass mode of UPS operation

mode of operation that the UPS attains when the load is supplied via the **bypass** only

3.2.12

UPS double conversion

any UPS operation, where **continuity of load power** is maintained by a UPS inverter, with energy supplied from the d.c. link in normal mode of operation or from the energy storage system in stored energy mode of operation

NOTE 1 The output voltage and frequency are independent of input voltage and frequency conditions.

NOTE 2 See Clause B.2.

3.2.13

UPS double conversion with bypass

UPS double conversion with the addition of an alternative bypass path for load supply

3.2.14

UPS line interactive operation

any UPS operation where, in normal mode of operation, the load is supplied with conditioned a.c. input power at the input supply frequency and where, in stored energy mode of operation, the load is supplied from the output of an inverter

NOTE See Clause E.3.

3.2.15

UPS line interactive operation with bypass

UPS line interactive with the addition of an alternative bypass path for load supply.

3.2.16

UPS passive stand-by operation

any UPS operation where the normal mode of operation consists of supplying the load from the primary power source, except when the latter is outside stated limits in which case the load is supplied from the UPS inverter operating in stored energy mode.

NOTE 1 The primary power may be regulated by additional devices, e.g. ferro-resonant or static regulators.

NOTE 2 See Clause B.4.

3.2.17

manual (control)

control of an operation by human intervention

[IEC 60050-441:1984, 441-16-04]

3.2.18**automatic (control)**

control of an operation without human intervention, in response to the occurrence of predetermined conditions

[IEC 60050-441:1984, 441-16-05]

3.2.19**semi-automatic (control)**

control of a switch where one of the operations (opening or closing) is automatically controlled while the other is manually controlled

3.2.20**synchronous transfer**

transfer within a limited voltage and phase angle difference as required for proper functioning of the load

3.2.21**synchronization**

adjustment of an a.c. power source to match another a.c. source in frequency and phase

3.2.22**asynchronous transfer**

transfer while the voltage phase angle difference is out of a tolerance band as declared by the manufacturer

3.2.23**electromagnetic interference****EMI**

degradation of the performance of an equipment, transmission channel or system caused by an electromagnetic disturbance

[IEC 60050-161:1990, 161-01-05]

3.2.24**equipment mobility**

NOTE Subclauses below are derived from IEC 60950-1.

3.2.24.1**movable equipment**

equipment which is either 18 kg or less in mass and not fixed, or equipment with wheels, castors or other means to facilitate movement by the operator as required to perform its intended use

3.2.24.2**stationary equipment**

equipment that is not movable equipment

3.2.24.3**fixed equipment**

stationary equipment which is fastened or otherwise secured at a specific location

3.2.24.4**equipment for building-in**

equipment intended to be installed in a prepared recess such as in a wall, or similar situation

3.2.25 accessibility

NOTE Subclauses below are derived from IEC 60950-1.

3.2.25.1 operator access area

area to which, under normal operating conditions, one of the following applies:

- a) access can be gained without the use of a tool;
- b) access can be gained without the use of a tool, the means of access being deliberately provided to the operator;
- c) the operator is instructed to enter regardless of whether or not tools are needed to gain access

The terms “access” and “accessible”, unless qualified, relate to operator access area as defined above.

3.2.25.2 service access area

area, other than an **operator access area**, to which it is necessary for service personnel to have access even with the equipment switched on

3.2.25.3 restricted access location

room or space where equipment is located, and where either:

- a) access can only be gained by service personnel with the use of a special tool or lock and key;
- b) access is controlled

3.2.25.4 tool

screwdriver or any other object which can be used to operate a screw, latch or similar fixing means

NOTE Derived from IEC 60950-1.

3.2.26 circuit characteristics

NOTE Subclauses below are derived from IEC 60950-1.

3.2.26.1 primary circuit

internal circuit which is directly connected to primary power

It includes the primary windings of transformers, motors, other loading devices and the means of connection to the primary power.

3.2.26.2 secondary circuit

circuit which has no direct connection to primary power

3.2.27 service personnel or service person

person having appropriate technical training and experience necessary to be aware of hazards to which that person may be exposed in performing a task and of measures to minimize the risks to that person or other persons

3.2.28**operator**

any person, other than a service person

NOTE The term operator in this standard is the same as the term user in IEC 62040-1. The two terms can be interchanged.

3.2.29**protective conductor current**

current in the protective conductor as measured by an ammeter of negligible impedance

NOTE Derived from IEC 60990.

3.2.30**type test**

testing of a representative sample of the equipment with the objective of determining if the equipment, as designed and manufactured, can meet the requirements of this standard

3.2.31**routine test**

test made for quality control by the manufacturer on every device or representative samples, or on parts or materials or complete equipments as required to verify during production that the product meets the design specification

[IEC 60050-151:2001, 151-16-17]

3.2.32**reliability integrity level RIL**

for a UPS, the probability of output power failure per hour in high demand or continuous mode of operation

RIL is a discrete level (one out of a possible four) for specifying the integrity requirements of the functions to be allocated to the UPS, where RIL level 4 has the highest level of integrity and RIL level 1 has the lowest.

NOTE The target failure measures for the four reliability integrity levels for UPS are specified in Annex K.

3.3 Specified values – General**3.3.1****rating**

set of rated values and operating conditions of a machine or a device or equipment

[IEC 60050-151:2001, 151-16-11, modified]

3.3.2**rated value**

value of a quantity used for specification purposes, generally established by a manufacturer for a specified set of operating conditions of a component, device, equipment, or system

[IEC 60050-151:2001, 151-16-08]

3.3.3**rated load**

load or condition in which the output of the UPS delivers the power for which the UPS is rated

NOTE 1 The rated load is expressed in apparent power (VA) and active power (W) resulting in a (rated) power factor that includes the effect of any applicable combination of linear and of non-linear load as prescribed in Annex E.

NOTE 2 Rated load is a value of load used for specification purposes, generally established by a manufacturer for a specified set of operating conditions of a component, device, equipment, or system.

3.3.4**reference linear load**

linear load or (linear) condition in which the output of the UPS delivers the apparent and active power for which the UPS is rated

NOTE 1 The reference linear load is expressed in apparent power (VA) and active power (W) resulting in a displacement power factor.

NOTE 2 The numerical value of the reference linear load equals that of the **rated load**.

NOTE 3 When applying the reference linear load, the UPS output current distortion should mirror the UPS output voltage distortion i.e. the reference linear load itself should not inject harmonic currents into the UPS.

3.3.5**reference test load**

load or condition in which the output of the UPS delivers the active power (W) for which the UPS is rated

NOTE This definition permits when in test-mode and subject to local regulations, the UPS output to be injected into the input a.c. supply.

3.3.6**reference non-linear load**

non-linear load that when connected to a UPS, consumes the apparent and active power for which the UPS is rated in accordance with Annex E

3.3.7**nominal value**

value of a quantity used to designate and identify a component, device, equipment, or system

NOTE The nominal value is generally a rounded value.

[IEC 60050-151:2001, 151-16-09]

3.3.8**limiting value**

in a specification of a component, device, equipment, or system, the greatest or smallest admissible value of a quantity

[IEC 60050-151:2001, 151-16-10]

3.3.9**current limit (control)**

function that maintains a current within its prescribed value

3.3.10**tolerance band**

range of values of a quantity within specified limits

3.3.11**deviation**

difference between the actual value and the desired value of a variable (quantity) at a given instant

[IEC 60050-351:2006, 351-21-04]

3.3.12**rated voltage**

the input or output voltage assigned by the manufacturer for a specified operating condition

[IEC 60050-442:1998, 442-01-03, modified]

3.3.13**rated voltage range**

input or output voltage range as declared by the manufacturer expressed by its lower and upper rated voltages

3.3.14**r.m.s. voltage variation**

difference between the r.m.s. voltage and the corresponding previously undisturbed r.m.s. voltage

NOTE For the purposes of this standard, the term "variation" has the following meaning: the difference of the values of a quantity before and after a change of an influence quantity.

3.3.15**peak voltage variation**

difference between the peak voltage and the corresponding value of the previously undisturbed waveform

3.3.16**phase angle**

angle (usually expressed in electrical degrees or radians) between reference points on one or more a.c. waveforms

3.3.17**rated current**

the input or output current of the equipment assigned by the manufacturer for a specified operating condition

[IEC 60050-442:1998, 442-01-02]

3.3.18**active power**

under periodic conditions, mean value, taken over one period T , of the instantaneous power p :

$$P = \frac{1}{T} \cdot \int_0^T p \cdot dt$$

NOTE 1 Under sinusoidal conditions, the active power is the real part of the complex power.

NOTE 2 The SI unit for active power is the watt.

NOTE 3 DC fundamental and harmonic voltages contribute directly to the magnitude of the active power. Appropriate instruments used to measure active power provide sufficient bandwidth to measure relevant non-symmetrical and harmonic power components.

[IEC 60050-131:2002, 131-11-42]

3.3.19**power factor**

ratio of the absolute value of the active power P to the apparent power S :

$$\lambda = \frac{|P|}{S}$$

[IEC 60050-131:2002, 131-11-46, modified]

NOTE For the purpose of this standard, the load power factor is determined assuming an ideal sinusoidal supply voltage. Where the load is non-linear, the load power factor includes harmonic power components.

3.3.20**apparent power**

product of the r.m.s. values of voltage and current at a port

$$S = UI$$

[IEC 60050-131:2002, 131-11-41, modified]

3.3.21**displacement power factor**

displacement component of the power factor; ratio of the active power of the fundamental wave to the apparent power of the fundamental wave

3.3.22**UPS efficiency**

ratio of output active power to input active power under specified testing conditions

NOTE Test conditions for UPS efficiency are found in Annex J.

3.3.23**rated frequency**

input or output frequency of the equipment assigned by the manufacturer for a specified operating condition

3.3.24**rated frequency range**

input or output frequency range as declared by the manufacturer, expressed by its lower and upper rated frequencies

3.3.25**frequency variation**

variation of the input or output frequency

3.3.26**total harmonic distortion****THD**

ratio of the r.m.s. value of the harmonic content of an alternating quantity to the r.m.s. value of the fundamental component quantity

[IEC 60050-551:1998, 551-17-06]

3.3.27**individual harmonic distortion**

ratio of the r.m.s. value of a special harmonic component to the r.m.s. value of the fundamental component

3.3.28**harmonic components**

components of the harmonic content as expressed in terms of the order and r.m.s. values of the Fourier series terms describing the periodic function

3.3.29**harmonic content**

quantity obtained by subtracting the fundamental component from an alternating quantity

[IEC 60050-551:1998, 551-17-04, modified]

NOTE The harmonic content may be given as a time-function or as an r.m.s. value.

3.3.30**transient**

behaviour of a variable during transition between two steady states

[IEC 60050-351:2006, 351-24-07, modified]

3.3.31**recovery time**

time interval between a step change in one of the control quantities or influence quantities and the instant when the stabilized output quantity returns to and stays within the steady-state tolerance band

3.3.32**stored energy time**

minimum time during which the UPS, under specified service conditions, will ensure **continuity of load power**, when the primary power fails

NOTE The energy storage system is assumed sufficiently charged according to 3.3.34.

3.3.33**cut-off voltage**

specified voltage of the energy storage system at which it is considered depleted

3.3.34**restored energy time**

maximum time required to, under normal mode of operation and with the charging capacity installed, recharge the energy storage system of the UPS so that stored energy time can again be achieved

3.3.35**ambient temperature**

temperature of the air or other medium where the equipment is to be used

[IEC 60050-826:2004, 826-10-03, modified]

3.4 Input values**3.4.1****input voltage tolerance**

maximum variation of steady-state input voltage specified by the manufacturer for normal mode operation

3.4.2**input frequency tolerance**

maximum variation of steady-state input frequency specified by the manufacturer for normal mode operation

3.4.3**input power factor**

ratio of the input active power to the input apparent power with the UPS operating in normal mode, at rated input voltage, rated load and with a fully charged energy storage system

3.4.4**UPS rated input current**

input current with UPS operating in normal mode, at rated input voltage, rated load and with a fully charged energy storage system

3.4.5**UPS maximum input current**

input current with UPS operating in normal mode, at worst-case input voltage, rated load and with a fully depleted energy storage system

3.4.6**UPS inrush current**

maximum instantaneous value of the input current when the UPS is switched on for normal mode

3.4.7**input current distortion**

maximum input current harmonic distortion, in normal mode

3.4.8**supply impedance**

impedance at the input terminals to the UPS with the UPS disconnected

3.4.9**high impedance failure**

failure where the supply impedance is regarded as infinite

3.4.10**low impedance failure**

failure where the supply impedance is negligible

3.4.11**short-circuit power****S_{sc}**

value of the three-phase short-circuit power calculated from the nominal interphase system voltage U_{nominal} and the line impedance Z of the system at the PCC:

$S_{\text{sc}} = U_{\text{nominal}}^2 / Z$, where Z is the system impedance at the power frequency

NOTE PCC means point of common coupling, see IEC 60050-161, Amendment 2:1998, 161-07-15.

3.4.12**rated apparent power of the equipment****S_{equ}**

value calculated from the rated line current I_{equ} of the piece of equipment stated by the manufacturer and the rated voltage U_p (single phase) or U_i (interphase) as follows:

- $S_{\text{equ}} = U_p I_{\text{equ}}$ for single-phase equipment and the single-phase part of hybrid equipment;
- $S_{\text{equ}} = U_i I_{\text{equ}}$ for interphase equipment;
- $S_{\text{equ}} = \sqrt{3} U_i I_{\text{equ}}$ for balanced three-phase equipment and the three-phase part of hybrid equipment;
- $S_{\text{equ}} = 3 U_p I_{\text{equ max}}$ for unbalanced three-phase equipment, where $I_{\text{equ max}}$ is the maximum of the r.m.s. currents flowing in any one of the three phases

In the case of a voltage range, U_p or U_i is a nominal system voltage according to IEC 60038 (for example: 120 V or 230 V for single-phase or 400 V line-line for three-phase).

3.4.13**short-circuit ratio** **R_{sce}**

impedance relation between a UPS and its a.c. input supply, defined as follows:

- a) $R_{sce} = S_{sc} / (3 S_{equ})$ for single-phase UPS;
- b) $R_{sce} = S_{sc} / (2 S_{equ})$ for interphase UPS;
- c) $R_{sce} = S_{sc} / S_{equ}$ for all three-phase UPS

3.5 Output values**3.5.1****output voltage**

r.m.s. value (unless otherwise specified for a particular load) of the voltage across the UPS output terminals

3.5.2**output voltage tolerance**

maximum variation of steady-state output voltage with the UPS operating in normal mode or in stored energy mode

3.5.3**periodic output voltage variation (modulation)**

periodic variation of the output voltage amplitude at frequencies less than the fundamental output frequency

3.5.4**output frequency tolerance**

maximum variation of steady-state output frequency with the UPS operating in normal mode or in stored energy mode

3.5.5**output current**

r.m.s. value of the current (unless otherwise specified for a particular load) from the output terminals

3.5.6**overload capability (or overload current)**

ratio of UPS output current capability over a given time to rated UPS output current, with the output voltage remaining within applicable limits, in normal or in stored energy mode

NOTE The power factor may be specified.

3.5.7**output active power**

active power available at the UPS output terminals

3.5.8**load sharing (between power sources)**

simultaneous supply of power to a load from two or more power sources

NOTE 1 Examples of load sharing include one load bus being supplied from two or more paralleled inverters.

NOTE 2 The share allocated to each power source is not necessarily the same.

3.5.9**load power factor**

characteristics of an a.c. load in terms expressed by the ratio of active power to apparent power assuming an ideal sinusoidal voltage

NOTE For practical reasons, the total load power factor including harmonic components may be stated in the manufacturer's technical data sheets.

3.5.10**output apparent power**

product of the r.m.s. output voltage and r.m.s. output current

3.5.11**rated output apparent power**

continuous output apparent power as declared by the manufacturer

3.5.12**rated output active power**

output active power as declared by the manufacturer

3.5.13**transfer time**

time interval between initiation of transfer and the instant when the output quantities have been transferred

NOTE The total transfer time in a UPS is the interval between the occurrence of an abnormality or out-of-tolerance condition and the instant when the output quantities have been transferred. This time equals the transfer time plus any detection time during which the abnormality is tolerated.

3.5.14**unbalanced load**

load, as seen by the supply, where current or power factor differs between any of the phases

3.5.15**step load**

instantaneous addition or removal of electrical loads to a power source

3.5.16**sinusoidal output voltage**

output voltage waveform complying with the compatibility levels for harmonic voltages in low voltage networks (refer to Table 1 of IEC 61000-2-2)

3.5.17**non-sinusoidal output voltage**

output voltage waveform not complying with the compatibility levels for harmonic voltages in low voltage networks (refer to Table 1 of IEC 61000-2-2)

3.5.18**voltage unbalance, voltage imbalance**

in a polyphase system, a condition in which the r.m.s. values of the phase voltages or the phase angles between consecutive phases are not all equal

[IEC 60050-161:1990, 161-08-09]

3.5.19

unbalance ratio

difference between the highest and the lowest r.m.s. values of the fundamental components in a three-phase a.c. system, referred to the average between three phases of the r.m.s. values of the fundamental components of the currents or voltages respectively

NOTE Unbalance may be expressed either by unbalance ratio (as prescribed by this standard) or by unbalance factor. Refer to IEC 60146-2 for further guidance.

4 Environmental conditions

4.1 Introduction

A UPS that complies with this standard shall, unless other values are agreed between manufacturer/supplier and purchaser, be capable of withstanding the conditions of an environment with pollution degree 2 and the conditions defined in this subclause.

NOTE Pollution degree is a characteristic of an environment and detailed in IEC 60664-1 from where the following is derived.

- Pollution degree 1 applies where there is no pollution or only dry, non-conductive pollution.
- Pollution degree 2 applies where there is only non-conductive pollution that might temporarily become conductive due to occasional condensation.
- Pollution degree 3 applies where a local environment within the equipment is subject to conductive pollution, or to dry non-conductive pollution that could become conductive due to expected condensation.

Transportation, storage and operation within the normal conditions prescribed (or specific unusual conditions if agreed upon) is essential. Nevertheless, the effective life of certain components, in particular the life of the energy storage device and/or its stored energy time may depend on the actual conditions to which the UPS is subjected. Refer to the UPS manufacturer for details on life limitations. Where the energy storage device, e.g. a battery, is purchased separately, refer to the battery manufacturer.

Additional conditions may be instructed by the UPS manufacturer, e.g. limiting the storage duration of an incorporated battery due to recharging requirements.

4.2 Normal conditions

4.2.1 Operation

4.2.1.1 Ambient temperature and relative humidity

A UPS conforming to this standard shall be able to perform as rated when operating within the following minimum ambient ranges:

- temperature 0 °C to +40 °C;
- relative humidity 20 % to 80 %.

A minimum ambient temperature range from +10 °C to +35 °C is tolerated for a UPS intended for indoor office applications.

4.2.1.2 Altitude

A UPS conforming to this standard shall be designed to operate as rated at an altitude up to and including 1 000 m above sea level.

If agreed between the manufacturer/supplier and the purchaser that the UPS shall operate at a specific altitude in excess of 1 000 m, the manufacturer shall state, for that altitude:

- new rated output power, if different from the **rated output power** specified for normal conditions;
- conditions, if any, for the UPS to support its rated overvoltage category 2, a requirement of IEC 62040-1.

NOTE 1 Overvoltage categories are specified in IEC 60664-1.

NOTE 2 The following Table 1 is provided for guidance. It is an example of the power derating required by altitude.

Table 1 – Power derating factors for use at altitudes above 1 000 m

Altitude		Derating factor	
m	feet	Convection cooling	Forced air cooling
1 000	3 300	1,000	1,000
1 200	4 000	0,994	0,990
1 500	5 000	0,983	0,975
2 000	6 600	0,970	0,950
2 500	8 300	0,955	0,925
3 000	10 000	0,940	0,900
3 500	11 600	0,925	0,875
3 600	12 000	0,922	0,870
4 000	13 200	0,910	0,850
4 200	14 000	0,904	0,840
4 500	15 000	0,895	0,825
5 000	16 500	0,880	0,800

NOTE 1 This table was derived from ANSI C57.96-1999 for loading of dry-type distribution and power transformers.

NOTE 2 Interpolation is allowed for altitudes not listed.

4.2.2 Storage and transportation

4.2.2.1 Ambient temperature and relative humidity

UPS equipment conforming to this standard shall accept stationary storage within a building and be transportable in its normal shipping container by a commercial and pressurised aircraft or by truck, within the following minimum ambient ranges:

- temperature $-25\text{ }^{\circ}\text{C}$ to $+55\text{ }^{\circ}\text{C}$;
- relative humidity 20 % to 95 % (non-condensing).

Containers not designed for wet (condensing) ambient conditions shall be marked by adequate warning labels.

NOTE When a battery is included, the duration of high or low ambient temperature may be limited as this may affect the battery life. The battery manufacturer's transportation and storage instructions should be observed.

4.2.2.2 Altitude

Unless otherwise declared by the UPS manufacturer, UPS equipment conforming to this standard shall be able to be stored at an altitude of 5 000 m above sea-level or less (or in an environment with equivalent air pressure).

4.3 Unusual conditions

4.3.1 Introduction

This subclause lists conditions that, subject to an agreement between the manufacturer and the purchaser, may require special design and/or special protection features. The purchaser shall identify any requirements that deviate from the normal conditions in Subclause 4.2.

4.3.2 Operation

Unusual environmental conditions to be identified include situations different from those normally encountered:

- pollution degree in excess of 2 (see Note in Subclause 4.1);
- temperature and relative humidity conditions exceeding those listed in 4.2;
- altitude conditions exceeding those listed in 4.2;
- exposure to abnormal vibration, shocks, tilting;
- exposure to earthquake acceleration forces;

NOTE Refer to IEC 60068-3-3.

- electromagnetic immunity exceeding the normative requirements of IEC 62040-2;
- radioactive immunity to radiation levels exceeding those of the natural background;
- any of the following: moisture, steam, fungus, insects, vermin dust, abrasive dust, corrosive gases, salt laden air or contaminated cooling refrigerant, damaging fumes, explosive mixtures of dust or gases, restriction of ventilation (for UPS and/or battery), radiated or conducted heat from other sources.

4.3.3 Storage and transportation

Unusual storage and transportation conditions to be identified include situations different from those normally applied to electronic equipment and batteries:

- temperature and relative humidity conditions exceeding those listed in 4.2;
- altitude conditions exceeding those listed in 4.2;
- exposure to abnormal vibration, shocks, tilting and to earthquake acceleration forces;
- special transportation and equipment handling requirements.

5 Electrical conditions, performance and declared values

5.1 General

5.1.1 UPS configuration

The UPS manufacturer/supplier shall declare and describe the UPS configuration, including

- quantity of UPS units and their topology;
- redundancy configuration as applicable;
- any major **UPS switch** necessary for connection, interruption, transfer, bypass or isolation;
- **operator access** or **restricted access** classification in accordance with IEC 62040-1.

NOTE 1 See IEC 60950-1 for the definition of operator and restricted access areas.

NOTE 2 The declaration and its description may reference the applicable subclauses and figures in Annexes A, B and C and be contained in a technical data sheet. Annex D presents a technical data sheet for guidance. This data sheet may be included in the UPS user manual.

5.1.2 Markings and instructions

UPS complying with this standard shall be marked and supplied with adequate instructions for the installation and operation of the UPS and its controls and indications. As a minimum, such markings and instructions shall be in accordance with the requirements detailed in Subclause 4.7, Markings and instructions, of IEC 62040-1.

5.1.3 Safety

For the purpose of protecting users, operators and service personnel against potential hazards including electric shock; energy related hazards; fire; heat related hazards; mechanical hazards; radiation; chemical hazards, UPS complying with this standard shall comply with the safety requirements of UPS prescribed in IEC 62040-1.

5.1.4 Electromagnetic compatibility

A UPS conforming to this standard shall conform to the electromagnetic emission and immunity requirements of IEC 62040-2.

5.2 UPS input specification

5.2.1 Conditions for normal mode operation

A UPS conforming to this standard shall be compatible with public low-voltage supplies and be capable of remaining in **normal mode of operation** when connected to an a.c. input supply presenting characteristics as follows:

- a) rated voltage;
- b) r.m.s. voltage variation $\pm 10\%$ of rated voltage;
- c) rated frequency;
- d) frequency variation $\pm 2\%$ of rated frequency;
- e) for three-phase input, voltage unbalance with an unbalance ratio of 5 %;
- f) total harmonic distortion (THD) of voltage $\leq 8\%$ with a maximum level of individual harmonic voltages according to the compatibility levels for individual harmonic voltages in low-voltage networks of IEC 61000-2-2. See Note 4 below;
- g) transient voltages, superimposed high-frequency voltages and other electrical noise such as that caused by lightning or capacitive or inductive switching; within the electromagnetic immunity levels prescribed in IEC 62040-2.

NOTE 1 A decrease in frequency is assumed not to coincide with an increase in a.c. line voltage and vice versa.

NOTE 2 If a bypass is used, its input should be within tolerances acceptable for the load.

NOTE 3 The above limits apply to public low voltage supplies. UPS designed for industrial applications or separately generated supplies may be required to meet more severe conditions. The purchaser should specify such conditions as applicable. In the absence of such information, the manufacturer/supplier may apply his experience as to the compatibility of the design for the intended installation.

NOTE 4 Compatibility levels for individual harmonic voltages in public low-voltage networks are specified in IEC 61000-2-2. The Table 2 below is an extract from IEC 61000-2-2 presenting such compatibility levels (r.m.s. values as percent of r.m.s. value of the fundamental component).

Table 2 – Compatibility levels for individual harmonic voltages in low voltage networks

Odd harmonics non-multiple of 3		Odd harmonics multiple of 3 ^a		Even harmonics	
Harmonic order n	Harmonic voltage %	Harmonic order n	Harmonic voltage %	Harmonic order n	Harmonic voltage %
5	6	3	5	2	2
7	5	9	1,5	4	1
11	3,5	15	0,3	6	0,5
13	3	21	0,2	8	0,5
17 ≤ n ≤ 49	$2,27 \times (17/n) - 0,27$	21 ≤ n ≤ 45	0,2	10 ≤ n ≤ 50	$0,25 \times (10/n) + 0,25$

NOTE All of the harmonic levels in this table are assumed not to occur simultaneously.

^a The levels given for odd harmonics that are multiples of three apply to zero sequence harmonics. Also, on a three-phase network without a neutral conductor or without load connected between line and ground, the values of the 3rd and 9th harmonics may be much lower than the compatibility levels, depending on the unbalance of the system.

5.2.2 Characteristics to be declared by the manufacturer

The manufacturer shall declare the actual and applicable input characteristics. In addition to those covered in 5.2.1, the following characteristics shall be declared:

- number of phases;
- neutral requirements;
- rated current;
- power factor at rated current;
- inrush current characteristics;
- maximum continuous current at the worst-case condition, including the effect of battery charging, mains tolerance (e.g. ± 10 % voltage tolerance) and any continuously permitted overload;
- overload current (where applicable curve of current against time);
- total harmonic distortion** (THD) of current;
- minimum **short-circuit power** capacity required from the a.c. input supply for compliance with maximum harmonic current distortion levels permitted in IEC 61000-3-2 (UPS ≤ 16 A), IEC 61000-3-12 (16 A < UPS ≤ 75 A), or IEC/TS 61000-3-4 (UPS > 75 A) where applicable. Where none of the standards mentioned apply, individual harmonic input current levels (n ≤ 40) measured or calculated at rated input current shall be declared when supplied with a voltage source of negligible distortion;
- earth leakage current characteristics (where in excess of 3,5 mA);
- a.c. power distribution system compatibility (TN, TT or IT as defined in IEC 60364-1).

NOTE The declaration may be in the form of a technical data sheet and may be included in the user manual. Annex D presents a technical data sheet for guidance.

5.2.3 Characteristics and conditions to be identified by the purchaser

The purchaser shall identify any conditions and characteristics that are more severe than those declared by the manufacturer.

Further, the purchaser shall identify any particular conditions that may be required by national wiring regulation and any adverse or special service conditions including

- a) pre-existing harmonic voltage distortion when in excess of 75 % of the IEC 61000-2-2 compatibility levels at the intended point of coupling of the UPS. Refer to Note 4 in 5.2.1;
- b) requirements for compatibility with characteristics of protective devices of the UPS input supply;
- c) requirements for all-pole isolation of the UPS from the a.c. input supply;
- d) stand-by generator characteristics, if any.

NOTE IEC 60034-22 may be consulted regarding characteristics for internal combustion engine-driven generating sets.

Such service conditions and deviations may require special design and/or protection features.

5.3 UPS output specification

5.3.1 Conditions for the UPS to supply a load

Subject to either

- the input conditions of 5.2.1 being satisfied, or
- the **energy storage system** being available,

a UPS conforming to this standard shall be capable of supplying loads (single or three-phase, as applicable) intended for connection to the public low voltage and that are compatible with the output characteristics of the UPS as declared by the manufacturer.

5.3.2 Characteristics to be declared by the manufacturer

The manufacturer shall declare the actual and applicable output characteristics, including

- a) performance classification (V ___ ___ in accordance with 5.3.4);
- b) rated voltage and steady state variation;
- c) rated frequency and free-running (non-synchronized) variation;
- d) maximum frequency range accepted by the UPS inverter for synchronization with bypass and maximum resulting **phase** angle between the inverter and bypass voltage waveforms;
- e) rate of change of frequency (slew-rate) when synchronizing;
- f) number of phases available;
- g) neutral availability;
- h) a.c. power distribution system compatibility (TN, TT or IT as defined in IEC 60364-1);
- i) total harmonic distortion (THD) of voltage while supplying rated steady state linear load and when supplying rated steady-state reference non-linear load as specified in Annex E and while operating
 - in normal mode,
 - in stored energy mode;
- j) output voltage transient deviation (r.m.s, time integral) and recovery time for a step change in load current for both linear and non-linear loads (see Annex E);
- k) rated active and apparent output power (W/kVA) and rated current¹;
- l) overload capability;

¹ Characteristic to be declared also for the bypass transfer switch when included with a single or parallel UPS.

NOTE 1 The figures given are valid under floating voltage of the energy storage system, if not otherwise agreed to.

- m) current limit identification given by the ratio of current limitation to rated output current which can be supplied by the UPS for a specified time while the UPS output voltage collapses accordingly;
- n) fault clearing capability: the rated fault clearing capability shall be given as the maximum load protective device rating with which the UPS can co-ordinate under fault conditions¹;
- o) rated **load power factor**¹;
- p) permissible **displacement power factor** range of the load ($\cos \Phi$)¹;
- q) voltage unbalance and phase angle displacement between line-to-line or line-to-neutral voltages resulting from 100 % load unbalance (multi-phase only);
- r) **UPS efficiency** at 25 %, 50 %, 75 % and at 100 % **reference test load** (refer to Annex J for guidance);

NOTE 2 The declaration may be in the form of a technical data sheet and may be included in the user manual. Annex D presents a technical data sheet for guidance.

NOTE 3 Particular performance characteristics under abnormal conditions, e.g. transfer time from UPS to bypass under non-synchronized conditions, may be declared.

5.3.3 Characteristics and conditions to be identified by the purchaser

The purchaser shall identify any condition and characteristic that are more severe than those declared by the manufacturer.

Further, the purchaser shall identify any particular condition that may be required by national wiring regulation and any adverse or special load condition, including

- a) loads generating harmonic currents, in particular even harmonic currents, except for loads complying with the maximum levels permitted in IEC 61000-3-2 (load ≤ 16 A), IEC 61000-3-12 (16 A < load ≤ 75 A), or IEC/TS 61000-3-4 (load > 75 A);
- b) asymmetric loads requiring circulation of a d.c. current, for example half-wave;
- c) independent earth of the output neutral required;
- d) load distribution facilities;
- e) requirements for all-pole isolation of the UPS from the load;
- f) requirements for coordination with characteristics of protective devices of the UPS load;
- g) future extension/expansion requirements;
- h) stand-by generator characteristics, if any;
- i) Functional availability (see Annex K) and degree of redundancy (see Annex A);
- j) output overvoltage protection.

5.3.4 Performance classification

The manufacturer shall classify UPS complying with this standard in accordance with the coding.

AAA BB CCC

where

AAA = Input dependency characteristic

¹ Characteristic to be declared also for the bypass transfer switch when included with a single or parallel UPS.

describing to which extent, for operation in normal mode, the load power depends on the quality of the a.c. input supply.

NOTE 1 This classification is performance-based and does not exclude any specific technology or topology as the means for achieving compliance with such classification.

“VFD”:

UPS classified VFD shall protect the load from power outage.

The output of the VFD UPS is dependent on changes in a.c., input voltage and frequency and is not intended to provide additional corrective functions, such as those arising from the use of tapped transformers.

Compliance with VFD classification is verified when performing test of 6.2.2.7 and by observing that as a minimum the UPS switches from normal mode of operation to battery mode while input voltage is interrupted

“VI”:

UPS classified VI shall protect the load as requested for VFD and in addition from:

- under-voltage applied continuously to the input;
- over-voltage applied continuously to the input.

An output voltage tolerance band narrower than input voltage window shall be defined by the manufacturer. The output of the VI UPS is dependent on a.c. input frequency and the output voltage shall remain within prescribed voltage limits (provided by additional corrective voltage functions, such as those arising from the use of active and/or passive circuits).

Compliance with VI classification is verified when performing tests of 6.4.1.1 and by observing that as a minimum the UPS output voltage remains within the prescribed limits and that the UPS remains in normal mode of operation while the input voltage is kept continuously (at least 1 min) at the maximum and the minimum value of the input voltage limits.

“VFI”:

UPS classified VFI is independent of supply (mains) voltage and frequency variations as specified in 5.2 and shall protect the load against adverse effects from such variations without depleting the stored energy source.

Compliance with VFI classification is verified when performing tests of 6.4.1.1 and 6.4.1.2 and by observing that as a minimum the output voltage and frequency remain within a specified output tolerance band while input voltage and frequency are moved in a wider input voltage and frequency tolerance band.

BB = Voltage waveform characteristic

describing the steady-state waveform of the voltage when operating in:

- normal or bypass mode (1st character);
- stored energy mode (2nd character).

“S”: voltage waveform is sinusoidal

- presenting total harmonic distortion $\leq 8\%$ and individual harmonic distortion within limits of Table 2 under all linear and reference non-linear load conditions.

“X”: voltage waveform is sinusoidal/non-sinusoidal

- meeting “S” specification under all linear load condition;
- not meeting “S” specification under rated non-linear load condition.

“Y”: voltage waveform is non-sinusoidal

- not meeting “S” specification under reference linear load condition.

Non-sinusoidal voltage waveforms shall present:

- peak voltage $U_p \leq \text{rated voltage} \times \sqrt{2}$;
- rise/fall rates $dU/dt \leq 10 \text{ V}/\mu\text{s}$.

Refer to the typical non-sinusoidal voltage waveform shown in Figure 1.



IEC 2038/03

Figure 1 – Typical “non-sinusoidal” output voltage waveform

Compliance with the voltage waveform classification declared is verified by performing the applicable steady-state electrical type tests described in 6.4.2.1 to 6.4.2.4 and 6.4.3.1, 6.4.3.2 and by observation that test results obtained are within the limits of applicable s, x, or y characteristics.

NOTE 2 Non-linear loads such as switch mode power supplies may tolerate non-sinusoidal voltage waveforms for a limited time. Subject to requirements from the load equipment manufacturer, this time is the stored-energy time (typically 5 min to 30 min).

CCC = Dynamic output performance

describes the voltage variation caused by:

- change of mode of operation (1st character),
- linear load step application (2nd character),
- non-linear load step application (3rd character),

where each character takes form of either 1, 2 or 3 with the following meaning:

“1”: performance is required for sensitive critical loads

The UPS output voltage remains within the limits of curve 1 of this subclause.

“2”: performance is accepted by most types of critical load

The UPS output voltage remains within the limits of curve 2 of this subclause.

“3”: performance is accepted by general purpose IT loads e.g. switched-mode power supplies.

The UPS output voltage remains within the limits of curve 3 of this subclause.

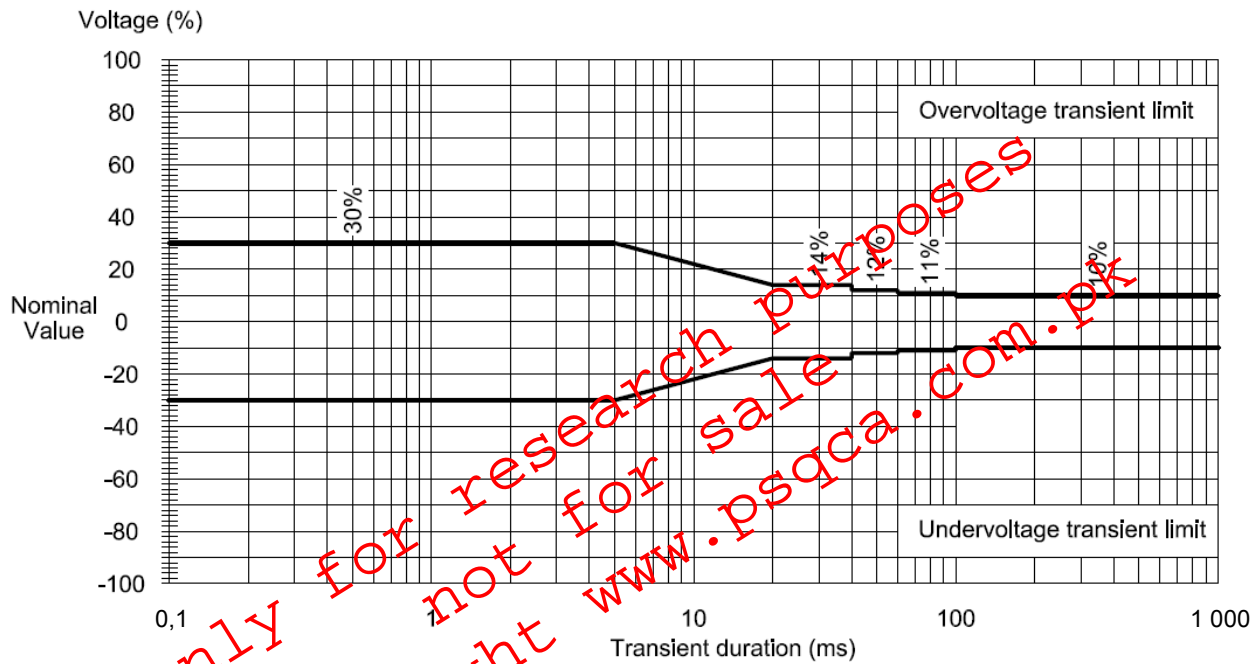

Figure 2 - Curve 1 - Dynamic output performance classification 1

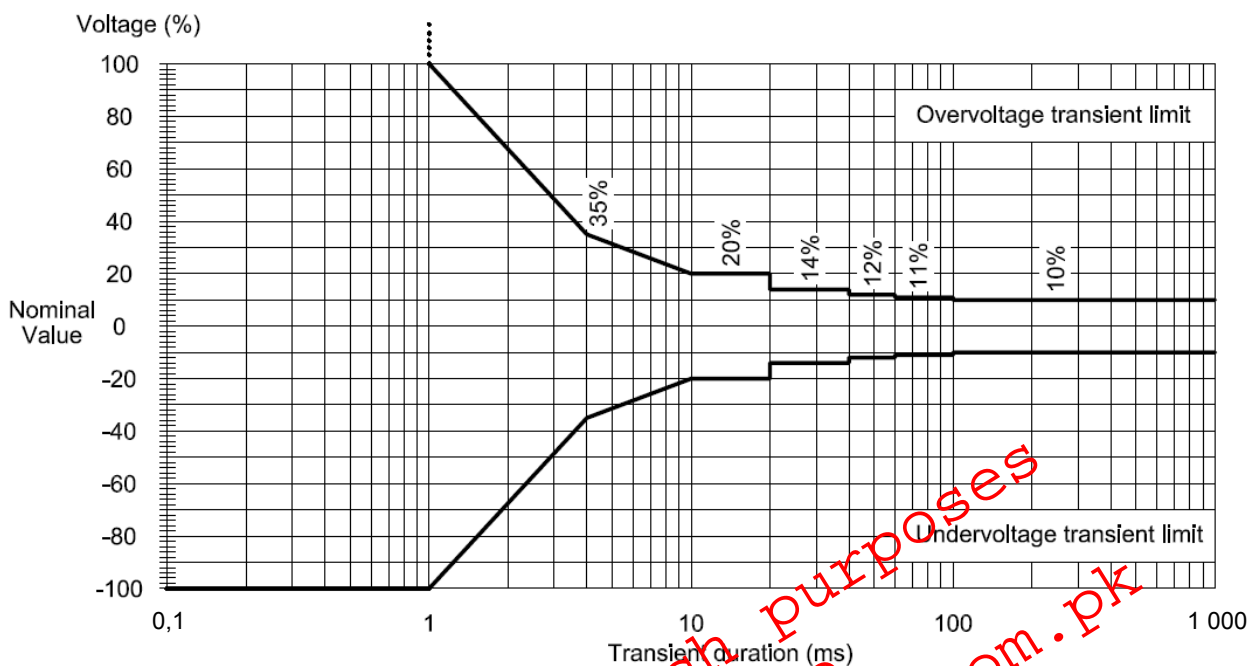

Figure 3 – Curve 2 – Dynamic output performance classification 2

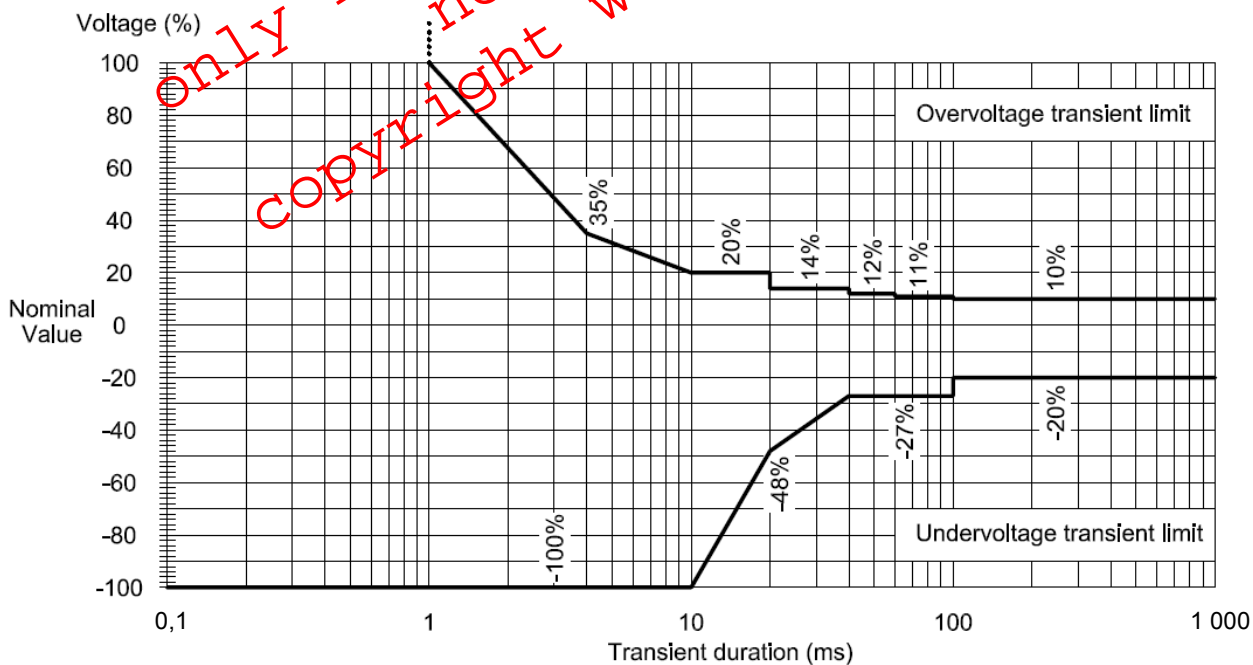

Figure 4 – Curve 3 – Dynamic output performance classification 3

Compliance with the dynamic output performance declared is verified by performing the electrical type tests described in 6.4.2.11 and 6.4.3.3 and by observation that test results obtained are within the limits of the applicable curve 1, 2 or 3.

NOTE 3 The objective of classifying UPS by performance is to provide a common base on which all UPS manufacturer's/supplier's data are evaluated. This enables purchasers, for similar UPS power ratings, to compare different manufacturer's products under the same measurement conditions.

NOTE 4 Purchasers are reminded that due to the diversity of load types, UPS manufacturers' data are based on industry standard test loads that simulate typical load applications expected.

NOTE 5 The actual performance in a given application may be subject to variation under transient conditions since actual load ratings, individual sequencing, and start currents may differ from standardized test situations.

NOTE 6 Single-cord connected UPS designed to be installed by the operator for use in an office environment, either desk or floor-mounted, and/or intended to be marketed by a third party without reference to the manufacturer, should, within the UPS rating, be capable of accepting any load suitable for connection to the public low voltage a.c. supply, unless any limitations are stated by the manufacturer within the user instructions.

NOTE 7 Non-linear step loading is performed as described in 6.4.3.3.3 and 6.4.3.3.4.

NOTE 8 Refer to Annex H for guidance on measurement techniques.

NOTE 9 Refer to Annex B for examples of applicable UPS topologies.

5.4 Stored energy specification

5.4.1 General

This subclause specifies details that apply to a **secondary battery**, presently the most common technology selected to provide energy storage for use when the a.c. input supply is unavailable.

It is recognised that other technologies, e.g. flywheel systems, may replace the need for a battery system. Such technologies may be fully compatible with UPS characteristics primarily intended for batteries. With this in mind, subject to an agreement between the manufacturer/supplier and the purchaser and where applicable, the specification may be used for other stored energy technologies.

5.4.2 Battery

5.4.2.1 Requirements for all batteries

A battery intended to serve as an energy storage system for a UPS complying with this standard shall comply with the IEC 62040-1 requirements for location, ventilation, marking and protection of a battery.

5.4.2.2 Characteristics to be declared by the manufacturer

The manufacturer shall declare the following battery characteristics e.g. in the user manual or in the UPS Technical data sheet (see Clause D.6):

- a) life (either design life or float service life - but not both);
- b) quantity of blocks or cells and of paralleled strings;
- c) nominal voltage of total battery;
- d) battery technology (vented or valve-regulated, lead-acid, NiCd, etc.);
- e) nominal capacity of total battery;
- f) stored energy time (see 6.4.4.1);
- g) restored energy time;
- h) ambient reference temperature;

- i) earth condition of d.c. link/isolation of d.c. link from input and/or output (remote battery only);
- j) r.m.s. ripple current during normal mode of UPS operation (if exceeding 5 % of the numerical Ah capacity [C10]);

When a remote battery is part of the supply, and if the power cabling and/or battery protection is not part of the supply, the following additional characteristics shall be declared:

- k) nominal discharge current during stored energy mode;
- l) d.c. fault current rating;
- m) cable voltage drop recommendation;
- n) protection requirements.

The manufacturer/supplier shall supply following additional information if requested by the purchaser:

- o) charging regime, i.e. constant voltage, constant current, boost or equalization capability, two-state charging;
- p) charging voltage and tolerance band;
- q) end of discharge voltage;
- r) charging current limit or range.

5.4.2.3 Characteristics and conditions to be identified by the purchaser

The purchaser shall identify any requirements, characteristics and conditions that deviate or are more severe than those listed in 5.4.2.1 and 5.4.2.2. This includes any particular conditions required by national regulation and any adverse or special service conditions including when a battery is supplied by 3rd parties.

NOTE National regulations may specify a minimum back-up autonomy time and define the type of energy storage to be used.

5.5 UPS switch specification

UPS switches supplied as an integral part of a UPS are covered by the prescribed electrical service conditions and performance requirements in this Clause 5 and need not to be specified separately.

Switches that are supplied separately and intended to operate in conjunction with the UPS shall be compatible with the applicable electrical service conditions and performance requirements of the UPS and shall specified in compliance with their own product standard.

Examples of product standards that apply to particular switches are:

- static transfer systems (STS): IEC 62310-3;
- automatic transfer systems (ATS): IEC 60947-6-1;
- manual isolation, tie and transfer switches: IEC 60947-3.

5.6 Communication circuits

The manufacturer shall provide adequate instructions for use and installation of any communication and signalling circuits supplied as an integral part of the UPS and intended to be connected to information technology equipment, e.g. programmable logic computers, local area networks (LAN) or to telecommunication networks.

6 UPS tests

6.1 Summary

6.1.1 Venue, instrumentation and load

6.1.1.1 Test venue

A UPS shall generally be tested at the manufacturer's premises and in accordance with Table 3.

Tests may be performed on the UPS in its complete form or, alternatively, on a functional unit or on a subassembly.

Testing of UPS may require facilities that are not available at the manufacturer's premises and/or facilities that are not economically justified within the scope of a particular supply. The manufacturer may then elect to

- a) use a 3rd party competent body to carry out compliance testing on the manufacturer's behalf. Evidence of 3rd party certification shall be deemed sufficient to prove compliance with the relevant clauses;
- b) demonstrate by calculation or by experience and/or testing of similar designs or sub-assemblies in similar conditions and through compilation of a technical construction file that the design is compliant. Evidence through a technical construction file shall be deemed sufficient to prove compliance with the relevant clauses;
- c) defer, subject to an agreement with the purchaser, applicable tests to be performed on site (see 6.3).

Separate tests on diverse functional units or subassemblies may be necessary for large and/or complex UPS configurations that cannot be completely tested prior to delivery on site. When such necessity arises, the functional unit test of 6.6 applies and the manufacturer/supplier and the purchaser should agree on conditions for final site testing. The manufacturer's recommendation should be followed in this respect.

6.1.1.2 Test instrumentation

Instruments used for the measurement of electrical parameters shall have sufficient bandwidth to accurately measure true r.m.s. value on waveforms which may be other than a fundamental sinewave, i.e. may present considerable harmonic content. Whichever type of instrumentation is used, its accuracy shall be in relation to the characteristic being measured and regularly calibrated in accordance with applicable standards. Refer to IEC 61000-4-30 for guidance on selection of instrumentation.

6.1.1.3 Test load

Load tests are performed as prescribed in the relevant test clause, by connecting loads to the UPS output to simulate representative actual load conditions, or by connecting the actual load when available.

Routine load tests are performed, where not otherwise prescribed in the relevant test clause, with **reference test load**.

Linear load tests are performed, where not otherwise prescribed in the relevant test clause, with **reference linear load**.

Non-linear load tests are performed, where not otherwise prescribed in the relevant test clause, with **reference non-linear load**. Large UPS that operate in parallel connection may be load-tested by testing individual UPS units separately.

NOTE In particular cases, a special load, including the actual site load, may be used if agreed upon between manufacturer/supplier and purchaser.

6.1.2 Routine test

Routine tests shall be performed on each UPS to verify that the requirements of this standard are met. Routine tests are generally performed before delivery, at the manufacturer's premises. Routine tests are listed in Table 3 and detailed in 6.2.

Test of characteristics other than those covered by routine tests is subject to an agreement between the manufacturer and the purchaser.

6.1.3 Site test

Uninterruptible power systems covered by this standard vary from complete small movable UPS with integral batteries, to large multi-module UPS that may be delivered as separate functional units intended for final assembly and wiring on site. Such large UPS may require their final performance test to be completed on site. Refer to 6.3 for more details.

6.1.4 Witness test

In addition to the routine tests performed by the manufacturer, the purchaser may wish their representative to witness testing of selected items of Table 3 and/or of other specific items.

Witness tests are subject to an agreement between the manufacturer and the purchaser.

NOTE The purchaser should evaluate the need for witness testing taking into account the manufacturer's quality assurance status.

6.1.5 Type test

Type tests shall be performed on a UPS that represents a series of substantially identical products. Type tests are intended to assure that such identical products become compliant with their full specification when produced under relevant quality standards and after having passed the routine tests detailed in 6.2. The UPS used for type-testing is not necessarily supplied to any purchaser. Type tests are listed in Table 3 and detailed in 6.4 and 6.5.

NOTE For UPS in series production, some of the type tests should be repeated at specified intervals on production samples to verify that the quality of the product is maintained.

6.1.6 Schedule of tests

Tests shall be performed in accordance with Table 3.

Table 3 – UPS test schedule

Test description	Routine test	Type test	Subclause
Cable and interconnection check	X	X	6.2.2.2
Control device(s)	X	X	6.2.2.3.a
Protective device(s)	X	X	6.2.2.3.b
Auxiliary device(s)	X	X	6.2.2.3.c
Supervisory, monitoring, signalling device(s)	X	X	6.2.2.3.d
Auto transfer to stored energy mode and back to normal	X	X	6.2.2.3.e
Auto transfer to bypass / isolation mode and back to normal	X	X	6.2.2.3.f
Manual transfer to bypass/isolation mode and back to normal	X	X	6.2.2.3.g
No load	X	X	6.2.2.4
Full load	X	X	6.2.2.5

Test description	Routine test	Type test	Subclause
Synchronization	X		6.2.2.6
AC input failure	X	X	6.2.2.7
AC input return	X	X	6.2.2.8
Parallel redundant UPS fault		X	6.4.2.12
Transfer test to bypass	X	X	6.2.2.9
Input supply compatibility			
Steady-state input voltage tolerance		X	6.4.1.1
Input frequency tolerance		X	6.4.1.2
Input inrush current		X	6.4.1.3
Harmonic distortion of input current		X	6.4.1.4
Power factor		X	6.4.1.5
Efficiency		X	6.4.1.6
Stand-by generator compatibility		X	6.4.1.9
Output – Linear load			
Normal mode – No load		X	6.4.2.1
Normal mode – Full load		X	6.4.2.2
Stored energy mode – No load		X	6.4.2.3
Stored energy mode – Full load		X	6.4.2.4
3-phase voltage unbalance		X	6.4.2.5
DC voltage component		X	6.4.2.6
Current division across paralleled UPS		X	6.4.2.7
Output overvoltage test		X	6.4.2.8
Periodic output voltage variation test (modulation)		X	6.4.2.9
Overload – Normal mode		X	6.4.2.10.1
Overload – Stored energy mode		X	6.4.2.10.2
Fault clearing capability – Normal mode		X	6.4.2.10.3
Fault clearing capability – Stored energy mode		X	6.4.2.10.4
Dynamic performance – Normal to stored energy mode		X	6.4.2.11.1
Dynamic performance – Stored energy to normal mode		X	6.4.2.11.2
Dynamic performance – Normal to bypass mode - overload		X	6.4.2.11.3
Dynamic performance – Step load – Normal mode		X	6.4.2.11.4
Dynamic performance – Step load – Stored energy mode		X	6.4.2.11.5
Output – Non-linear load			
Normal mode – Full load		X	6.4.3.1
Stored energy mode – Full load		X	6.4.3.2
Dynamic performance – Normal to stored energy mode		X	6.4.3.3.1
Dynamic performance – Stored energy to normal mode		X	6.4.3.3.2
Dynamic performance – Step load – Normal mode		X	6.4.3.3.3
Dynamic performance – Step load – Stored energy mode		X	6.4.3.3.4
Stored and restored energy times			
Stored energy time		X	6.4.4.1
Restored energy time		X	6.4.4.2
Battery ripple current		X	6.4.4.3

Test description	Routine test	Type test	Subclause
Restart test		X	6.4.4.4
Environmental			
Repetitive shock during transportation		X	6.5.2.1
Free-fall during transportation		X	6.5.2.2
Storage in dry heat, damp heat and cold environments		X	6.5.3
Operation in dry heat, damp heat and cold environments		X	6.5.4
Acoustic noise		X	6.5.5
Safety		X	Refer IEC 62040-1
Electromagnetic compatibility		X	Refer IEC 62040-2

6.2 Routine test procedure

6.2.1 Environmental

No routine tests are required.

NOTE Refer to 6.5 for environmental type tests.

6.2.2 Electrical

6.2.2.1 Insulation and dielectric

Insulation and dielectric is a safety requirement not within the scope of this standard.

NOTE Insulation and dielectric compliance is verified during the applicable UPS safety certification. See 8.2 of IEC 62040-1.

6.2.2.2 Cable and interconnection check

The UPS shall be inspected in accordance with the manufacturer's installation and wiring diagrams to determine that:

- all a.c. and d.c. supply terminals are connected to the a.c. input supply, to the stored energy source (as applicable) and to the load;
- any communication circuit is connected as required.

Further, all temporary test connections introduced or removed during any insulation and dielectric tests shall be confirmed as having been restored to their normal condition.

6.2.2.3 Light load and functional test

The light load test is a functional test carried out to verify that the UPS is correctly connected and that all functions operate properly. The load applied is limited, for practical and cost reasons, to a percentage of the rated value, for example 10 %. Correct operation of the following shall be verified:

- a) all control switches and other means to activate UPS operation;
- b) protective devices (refer to 7.5.3 of IEC 60146-1-1);
- c) auxiliary devices, such as contactors, fans, outlets, annunciators and communication devices;
- d) supervisory, monitoring and remote signalling devices (if any);

- e) auto transfer to stored energy mode and back to normal mode by failing and subsequently restoring the a.c. input voltage;

NOTE 1 This test may be performed in conjunction with a.c. fail/return tests of 6.2.2.7 and 6.2.2.8.

- f) auto transfer to bypass or isolation of the inverter from a common a.c. output bus (as applicable) and back to normal mode by failing and subsequently restoring the inverter a.c. output voltage;

NOTE 2 This test may be performed in conjunction with parallel/bypass tests of 6.2.2.9 and 6.4.2.12.

- g) manual transfer to bypass or isolation of the inverter from a common a.c. output bus and back to normal mode (as applicable) by operating appropriate switches and/or controls.

Compliance is verified by observation that the devices and functions intended to control, protect, supervise, measure and signal UPS activities perform as expected and that the load voltage remains within specified values during the manual and automatic transfers.

6.2.2.4 No load

The UPS output voltage shall remain within the specified values when the UPS operates at nominal input voltage and frequency and with no load connected at the output.

6.2.2.5 Full load

The UPS shall remain in normal mode of operation and its output voltage within the specified values when operating at nominal input voltage and frequency while supplying a reference test load.

Large UPS in parallel connection may be load tested by testing the individual UPS units separately or as a whole.

6.2.2.6 Synchronization

This test shall be performed when synchronization to an external source is required. The test shall be performed in normal mode and at light load. The voltage and frequency of the external source, e.g. the bypass source shall be that prevailing at the test site and shall be stable and within the characteristics specified in 5.2.1.

Compliance is verified when, in steady-state, the phase angle between the inverter and the external source voltage waveforms is equal or less than that declared by the manufacturer.

This test may be performed in conjunction with another test if it is more convenient.

6.2.2.7 AC input failure

The test shall be performed with a battery or other appropriate d.c. source. The input failure should be conducted by interrupting the a.c. input as far upstream as practical and carried out in accordance with Annex G, Clause G.2 (and Clause G.3 for type test only).

Compliance is verified when, following the input a.c. failure, the UPS operates in stored energy mode within steady state output voltage and frequency limits specified in 5.3.4.

The UPS shall not be damaged during operation with the loss of one phase (type test only).

NOTE This test may be performed in conjunction with the light load test of 6.2.2.3.e.

6.2.2.8 AC input return

This test shall be performed either by restoring the **a.c. input power**, or simulated by energizing all UPS input feeders at the same time. This test shall normally be performed with a battery or appropriate d.c. source.

Proper operation of all UPS rectifiers, including walk-in, if applicable, shall be observed. AC output voltage and frequency variations shall also be measured.

Compliance is verified when, following the input a.c. return, the UPS operates in normal mode within steady state output voltage and frequency limits specified in 5.3.4.

The UPS shall not be damaged upon a.c. return with improper phase rotation (type test only).

NOTE 1 Walk-in is a function that controls the input a.c. current so that it increases gradually within a specified time when the UPS starts or restarts. Walk-in is also called soft-start.

NOTE 2 This test may be performed in conjunction with the light load test of 6.2.2.3.e).

6.2.2.9 Transfer to bypass

This test shall be performed for UPS with bypass capability, particularly in the case of an electronic bypass switch.

The test shall be conducted with rated load applied to the output of the UPS. By failure simulation or output overload, the load shall be transferred to the bypass automatically and then back to the UPS either automatically or operator controlled when failure simulation or output overload is removed.

The output voltage transient shall be measured and comply with the manufacturer's declared limits. The phase angle between the bypass and the UPS inverter shall also be observed during this operation.

NOTE This test may be performed in conjunction with the full load test of 6.2.2.5.

6.3 Site test procedure

UPS that are delivered as separate functional units intended for final on-site assembly and wiring require their final performance tests to be completed on site. The site test procedure generally consists of the manufacturer's commissioning procedure and of completion of any routine tests of Table 3 that were not completed prior to delivery.

Site tests shall preferably occur under conditions representing those of actual service and shall use the load available on site. The load shall not exceed the rated continuous load of the complete UPS as configured on site.

Where not otherwise prescribed in the relevant test clause, tests shall be performed with reference test load as defined in 3.3.5.

NOTE 1 The purchaser may, subject to an agreement with the UPS manufacturer, formulate a specific site acceptance test (SAT) schedule as part of a purchase contract.

NOTE 2 The purchaser should, for economic reasons and to avoid unnecessary stress to the UPS, confine the site-test schedule to verify essential characteristics not otherwise verified.

6.4 Type test procedure (electrical)

6.4.1 Input – a.c. supply compatibility

The a.c. input supply shall present the applicable power distribution characteristics declared for the UPS (see 5.2.2.k) and be capable of

- maintaining the voltage waveform within the limits of IEC 61000-2-2 when the UPS operates in normal mode at rated output apparent power. See Note 4 in 5.2.1;
- providing a variable frequency and voltage within the characteristics declared for the UPS input (see 5.2.1).

NOTE Alternative test methods in the absence of a variable frequency/voltage generator are permitted.

6.4.1.1 Steady-state input voltage tolerance

With the UPS in normal mode of operation and input frequency set at nominal frequency, the input voltage shall be adjusted to the minimum and maximum values of the tolerance range specified by the manufacturer. The UPS shall remain in normal mode of operation over the specified tolerance range with the ability to recharge the battery.

The UPS output voltage shall be measured and its tolerance recorded at nominal, minimum and maximum input voltage.

Where the design of the UPS prevents normal mode of operation above 10 % of nominal supply voltage by a change of mode to stored energy mode, the value recorded shall be the voltage prior to change of mode. The input voltage shall be the maximum rated input voltage to ensure operation without circuit damage.

6.4.1.2 Input frequency tolerance

The steady-state input voltage tolerance test (see 6.4.1.1) shall be repeated with the input frequency adjusted to the limits specified by the manufacturer in conjunction with the input voltage variations (see Note). The UPS shall remain operating in normal mode.

Where the UPS output frequency is synchronized with the input frequency, the range of synchronization shall be checked compliant with the maximum phase angle between the inverter and input voltage waveforms while the input frequency is varied at maximum slew-rate (see 5.3.2.d) and 5.3.2.e)).

NOTE A decrease in frequency is assumed not to coincide with an increase in line voltage, and vice versa.

6.4.1.3 Inrush current

Two inrush current tests shall be performed sequentially. The first test shall be performed after an absence of input voltage for more than 5 min.

The subsequent test shall be performed after an absence of input voltage for 1 s. If the UPS topology requires a time delay greater than 1 s, the test shall be performed with the manufacturer specified delay, which shall be stated in the installation instructions.

For the purpose of this test, initial current surges attributable to energization of RFI capacitors in input filters with a time duration of less than 1 ms shall be disregarded.

The **a.c. input power** supply shall be capable of providing a prospective short-circuit current so that the **short-circuit ratio R_{sce}** is at least 33. Testing at an R_{sce} lower than 33 is permitted when the test result is corrected by an appropriate calculation.

The mains input supply shall be switched on to the UPS input coincident with various angular points on the input voltage waveform in order to determine the worst-case inrush current condition.

NOTE The test should be repeated sufficiently to obtain worst-case peak current which will normally be found for transformer coupled units, when switched at the zero voltage point and for direct rectifier/capacitor loads at or near the peak of the input supply voltage waveform.

6.4.1.4 Harmonic distortion of input current

The harmonic distortion of the input current is tested at **reference test load**.

Compliance is verified when the total harmonic distortion figures of the UPS input current are within the limits declared by the manufacturer.

NOTE 1 The limits declared by the manufacturer should at least comply with those prescribed by IEC 61000-3-2 (UPS ≤ 16 A), IEC 61000-3-12 (16 A < UPS ≤ 75 A), or IEC/TS 61000-3-4 (UPS > 75 A) taking into consideration the minimum **short-circuit power** capacity of the a.c. input supply as declared by the manufacturer.

NOTE 2 Where the reference test load is implemented by means of returning the output power to the UPS input, the harmonic distortion of the input current of concern is that actually drawn by the UPS input (as opposed to that drawn from the a.c. input source).

6.4.1.5 Power factor

The input power factor is tested at **reference test load** in normal mode of operation and at rated a.c. input supply conditions.

Compliance is verified when the input power factor of the UPS input current is equal or greater than that declared by the manufacturer.

NOTE Where the reference test load is implemented by means of returning the output power to the UPS input, the input power factor of concern is that referred to the current actually drawn by the UPS input (as opposed to that drawn from the a.c. input source).

6.4.1.6 Efficiency

The **UPS efficiency** shall be measured at 25 %, 50 %, 75 % and 100 % **reference test load** as prescribed in Annex J.

Compliance is verified when the computed efficiency values are equal to or greater than those declared by the manufacturer.

NOTE Refer to Annex I for applicable minimum efficiency values to be considered.

6.4.1.7 Backfeed protection

Automatic backfeed protection is a safety requirement not within the scope of this standard.

NOTE Backfeed protection compliance is verified during the applicable UPS safety certification. See Annex I of IEC 62040-1.

6.4.1.8 Residual earth current

Residual earth current ("earth leakage") is a safety requirement not within the scope of this standard.

NOTE Earth leakage compliance is verified during the applicable UPS safety certification. See Subclause 8.1 General provisions for earth leakage of IEC 62040-1.

6.4.1.9 Stand-by generator compatibility test

The applicable routine tests listed in Table 3 shall be repeated using the output of a stand-by generator as the source of input supply. The characteristics of the stand-by generator shall be specified by the manufacturer.

NOTE 1 This test may be performed in conjunction with the input voltage and frequency tolerance tests (see 6.4.1.1 and 6.4.1.2).

NOTE 2 Subject to an agreement between the manufacturer/supplier and the purchaser, this test may be performed on site.

NOTE 3 IEC 60034-22 may be consulted regarding characteristics for internal combustion engine driven generating sets.

6.4.1.10 Electromagnetic compatibility

Electromagnetic compatibility is an emission and susceptibility requirement not within the scope of this standard.

NOTE Electromagnetic compatibility compliance is verified during the applicable UPS EMC certification. See IEC 62040-2.

6.4.2 Output – Linear load

Where the manufacturer/supplier specifies the power factor range of the load that can be connected to the UPS output, the following tests shall include measurement of parameters at each end of the power factor range in addition to any nominal power factor measurement taken.

Where not otherwise prescribed in the relevant test clause, the test shall be performed at **reference linear load**.

6.4.2.1 Normal mode – No load

With the UPS operating in normal mode of operation at no load and nominal input voltage and frequency, measure the r.m.s. output voltage and its fundamental and harmonic components.

6.4.2.2 Normal mode – Full load

Apply 100 % **reference test load** to the UPS output.

In steady-state conditions, measure the r.m.s. output voltage and its fundamental and harmonic components. Compute no-load to full-load output voltage regulation.

For UPS whose output in normal mode of operation is directly connected solely by a switching device to the input supply, the harmonic content test is unnecessary.

6.4.2.3 Stored energy mode – No load

With the UPS operating in stored energy mode and the output at no-load, measure the output voltage, frequency and its fundamental and harmonic components.

6.4.2.4 Stored energy mode – Full load

Apply 100 % reference test load to the UPS output. In steady-state conditions at the beginning of battery discharge time, measure the output voltage, frequency and its fundamental and harmonic components. Compute the no-load to full-load output voltage regulation.

NOTE This test requires instrumentation with scanning time sufficient to observe changes resulting from the storage device voltage fall with time. For UPS with a storage device rated for less than 10 min, it is permissible to connect an additional battery to enable testing and to stabilise measurements.

6.4.2.5 3-phase unbalance

Output voltage unbalance on three-phase output UPS shall be checked under symmetrical load conditions and unbalanced load conditions. For the unbalanced load condition, two phases shall be loaded phase to phase or phase to neutral if a neutral exists at nominal rated current linear load, the other phase at no load unless otherwise specified by the manufacturer/supplier.

Phase-to-phase and phase-to-neutral (if neutral provided) output voltage are to be observed. Voltage unbalance shall be given in terms of **voltage unbalance ratio**. Phase angle deviations shall be determined by calculation from the values of phase-to-phase and phase-to-neutral voltages.

6.4.2.6 DC component

The 10 s average d.c. output voltage shall be less than 0,1 % of r.m.s. value.

6.4.2.7 Load sharing test

Load sharing shall be measured for reference, (at the output of two or more UPS units in parallel configuration) in accordance with the manufacturer's specification or with any specific agreement between the manufacturer and purchaser.

6.4.2.8 Output overvoltage test

Output overvoltage protection shall be checked.

6.4.2.9 Periodic output voltage variation test (modulation)

Only when, subject to a specific agreement between the purchaser and the manufacturer, this test is specified, it shall be checked by voltage recording at different loads and operating conditions.

Compliance is verified when, during the test, the UPS output voltage remains within the limits of curve 1, 2 or 3 of Figures 2, 3 and 4, as applicable.

6.4.2.10 Overload and fault clearing capability

6.4.2.10.1 Overload – Normal mode

With the UPS operating under a light load in normal mode, apply a resistive load which shall result in the UPS output in excess of the manufacturer's full load rating. Check that the UPS continues to operate within the manufacturer's stated conditions for the time duration specified.

NOTE In some cases, the UPS will change mode of operation to bypass mode where so declared by the manufacturer.

The UPS shall not be damaged, or show signs of over-heating.

6.4.2.10.2 Overload – Stored energy mode

The test of 6.4.2.10.1 shall be repeated in stored energy mode, with the storage energy device fully charged. The UPS shall not be damaged and shall function correctly when restarted.

6.4.2.10.3 Fault clearing capability – Normal mode

With the UPS operating under normal mode test conditions of 6.4.2.1, a light load may be applied if desired (see 6.2.2.3). A short circuit shall then be applied through a suitable fuse or circuit-breaker of a current rating in accordance with the manufacturer or supplier's stated protective device clearance capability (see 5.3.2 n).

The manufacturer or supplier shall state whether a static bypass circuit takes part in the fault clearance.

Compliance is verified when the dynamic output performance remains within the limits of Figures 2, 3 or 4 during this event unless otherwise stated by the manufacturer or supplier.

If the UPS is rated for operation at multiple input and output voltages, the short circuit test shall be performed at the highest nominal rated input and output voltages.

The manufacturer may specify conditions for compliance, provided that such conditions represent realistic site conditions.

NOTE 1 A fault clearing capability test verifies the UPS output performance when applying a conditional short-circuit. The manufacturer may specify conditions for compliance, provided that such conditions represent realistic site conditions. Typical conditions may include a lower limit for the impedance of cables connecting the UPS output to the protective device and to the short-circuit.

NOTE 2 Safety requirements related to UPS short-circuit currents are specified in IEC 62040-1.

6.4.2.10.4 Fault clearing capability – Stored energy mode

The test of 6.4.2.10.3 shall be repeated in stored energy mode unless the manufacturer or supplier states that the UPS cannot co-ordinate with external protective devices in this mode of operation.

6.4.2.11 Dynamic performance

6.4.2.11.1 Normal to stored energy mode

With the UPS initially operating at full load in normal mode, the input supply shall be interrupted for a minimum of 1 s, starting at each of the following conditions independently:

- a) where the input voltage waveform passes through zero;
- b) at the peak of the input voltage waveform.

At each of these conditions, the tests shall be performed a minimum of three times to ascertain repeatability.

The UPS input and output waveforms shall be observed on suitable storage instrumentation to permit the calculation of any transient performance deviation of the output voltage waveform during the transition from normal to stored energy mode of operation.

6.4.2.11.2 Stored energy to normal mode

With the UPS initially operating a full load in stored energy mode, the input supply shall be reconnected (at any angular position on the input supply waveform) and the output observed for any deviation during the transition from stored energy mode to normal mode of operation. This test is generally performed in conjunction with the previous test (see 6.4.4.1).

Where synchronization is a feature of the UPS, during a time interval covering the transition back to normal mode, the input and output voltage waveforms shall be checked to ensure that, at the point of transition, the phase angle between the input supply voltage waveform and output voltage waveform does not exceed any limits stated.

NOTE This test requires instrumentation that can capture a delayed time event since the synchronization period prior to change of mode is a variable. In some cases, it may be possible to use communication signals from the UPS or trigger signals within the UPS to assist in this test. Where this is not possible, the test is done by comparison of both waveforms in time intervals.

6.4.2.11.3 Normal to bypass mode – Overload

Where the UPS has a bypass mode of operation which is automatic in operation under conditions of output overload or UPS inverter fault, the overload test 6.4.3.1 shall be repeated to force bypass operation due to overload. The input and output voltage waveforms shall be

observed during transitions normal to bypass mode, and vice versa, which shall remain within stated values.

Where in addition the manufacturer declares that automatic change to bypass mode is inhibited if the bypass voltage or frequency is out of tolerance (except under certain fault conditions), the input supply voltage and frequency shall be adjusted beyond the specified range to demonstrate compliance with the UPS specification beyond which the UPS operation in bypass mode is inhibited.

6.4.2.11.4 Step load – Normal mode

With the UPS operating in normal mode under no load, apply a resistive load equal to 100 % output active power, comprising two loads: one equal to 20 % and one equal to 80 %.

At the point of application of the load when the output waveform is at its peak value, observe the output waveform on suitable storage instrumentation to permit calculation of any dynamic performance deviation.

Reduce the load to 20 % of rated output active power by switching off the 80 % load. Repeat the previous measurements at the instant of disconnection and compute the value, which shall remain within the stated limits.

6.4.2.11.5 Step load – Stored energy mode

Repeat the previous test except that the UPS shall operate in stored energy mode.

only for research purposes
not for sale
copyright www.psgca.com.pk

6.4.2.11.6 Test method – Linear load

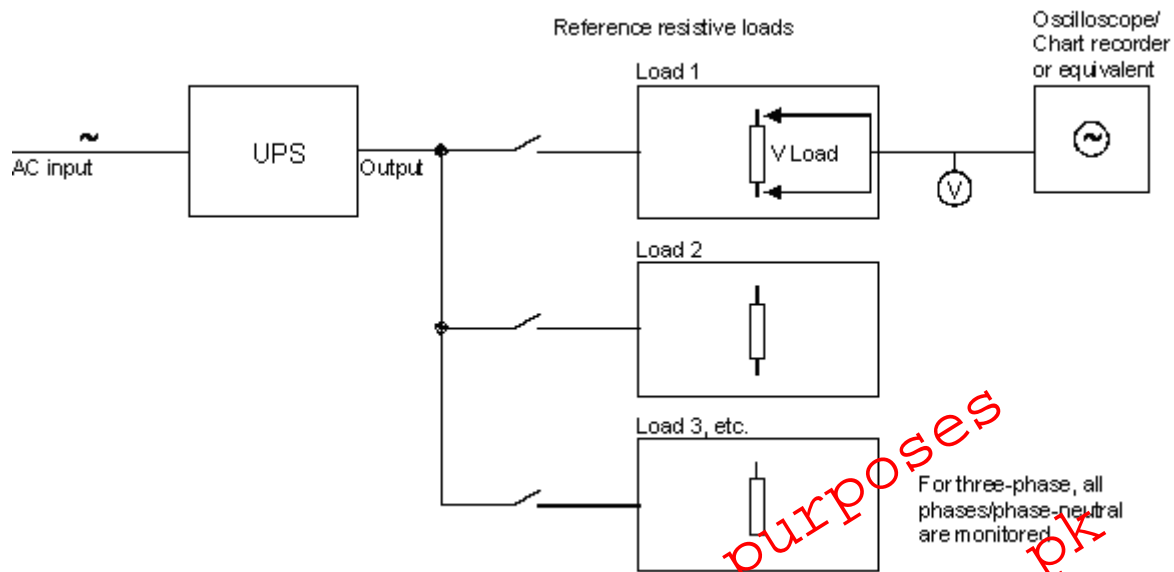

Figure 5 – Linear load test method

The UPS output voltage waveform is observed in conjunction with the current waveform to determine voltage variation and time duration of the transient.

Change of mode:

Using the test circuit of Figure 5, initiate the change of mode under conditions as required by the relevant test procedure. While initiating the change of mode, observe the change voltage and determine if compliance with the limits of applicable curve 1, 2 or 3 of 5.3.4 is achieved.

Step load:

Using the test circuit of Figure 5, apply the specific linear load step under conditions as required by the relevant test procedure. Observe the voltage deviation over time and determine if compliance with the limits of applicable curve 1, 2 or 3 of Figure 2, 3 or 4 is achieved.

6.4.2.12 Simulation of parallel redundant UPS fault

This test is required for UPS incorporating parallel redundancy. The test shall be conducted with rated load applied to the UPS. By failure simulation, the redundant functional units or UPS units shall be made to fail (e.g. inverter semiconductor failure). The output voltage transients and frequency shall be measured and shall comply with the manufacturer's declared limits. Both **high** and **low impedance failures** in redundant UPS shall be considered.

Low impedance failure mode should be simulated by shorting an appropriate power semiconductor in the redundant UPS. **High impedance failure** mode should be simulated by opening the connection to an appropriate power semiconductor in the redundant UPS.

6.4.3 Output – Non-linear load

Where not otherwise prescribed in the relevant test clause, tests shall be performed with non-linear load as defined in Annex E.

6.4.3.1 Normal mode – Full load

With the UPS operating in normal mode of operation, apply a reference non-linear load (see Annex E) set to obtain rated output apparent power for the UPS under test.

In steady-state conditions, measure the output voltage waveform and its fundamental and harmonic content. The values shall not exceed the manufacturer's stated value.

6.4.3.2 Stored energy mode – Full load

Repeat the previous test (see 6.4.3.1) except that UPS shall operate in stored energy mode.

6.4.3.3 Dynamic performance

6.4.3.3.1 Normal to stored energy mode

Repeat the change of mode test of 6.4.2.11.1 except that 100 % reference non-linear load shall be used instead of a linear load. Refer to Annex E for guidance about reference non-linear load.

6.4.3.3.2 Stored energy to normal mode

Repeat the change of mode test of 6.4.2.11.2 except that 100 % reference non-linear load shall be used instead of a linear load. Refer to Annex E for guidance about reference non-linear load.

6.4.3.3.3 Load step – Normal mode

Apply load steps in accordance with the UPS rating as follows:

a) UPS \leq 4,0 kVA rating

With the UPS operating at no load in normal mode, apply, as a base load, a reference non-linear load set to obtain 25 % of rated output apparent power (see Annex E).

In steady-state conditions, apply at the peak value of the output voltage waveform an additional reference non-linear load set to 75 % of rated output apparent power. At the instant of application of the additional load, measure the output voltage waveform transient deviation.

In steady-state conditions, switch off the reference non-linear load set to 75 % rated output apparent power at the peak value of the output voltage waveform. At the time of disconnection, repeat the measurements of output voltage waveform transient deviation.

b) UPS $>$ 4,0 kVA rating

With the UPS operating at no load in normal mode, apply, as a base load, a reference non-linear load set to obtain 33 % of rated output apparent power (see Annex E).

In steady-state conditions, apply at the peak value of the output voltage waveform an additional reference non-linear load set to 33 % of rated output apparent power. At the instant of application of the additional load, measure the output voltage waveform transient deviation.

With 66 % base load, apply at the peak of the output voltage waveform a further 33 % reference non-linear step load and repeat measurement of transient voltage deviations.

In steady-state conditions, switch off 33 % of the step reference non-linear load at the peak of the output voltage waveform. At the time of disconnection, repeat measurements of the output voltage waveform.

Repeat, switching off the next 33 % step reference non-linear load to return to the original 33 % base load and recording the transient deviation of the output waveform.

Compliance is verified in accordance with 6.4.3.3.5.

6.4.3.3.4 Load step – Stored energy mode

The previous test (see 6.4.3.3.3) shall be repeated in the stored energy mode.

Compliance is verified in accordance with 6.4.3.3.5.

6.4.3.3.5 Test method – Non-linear load

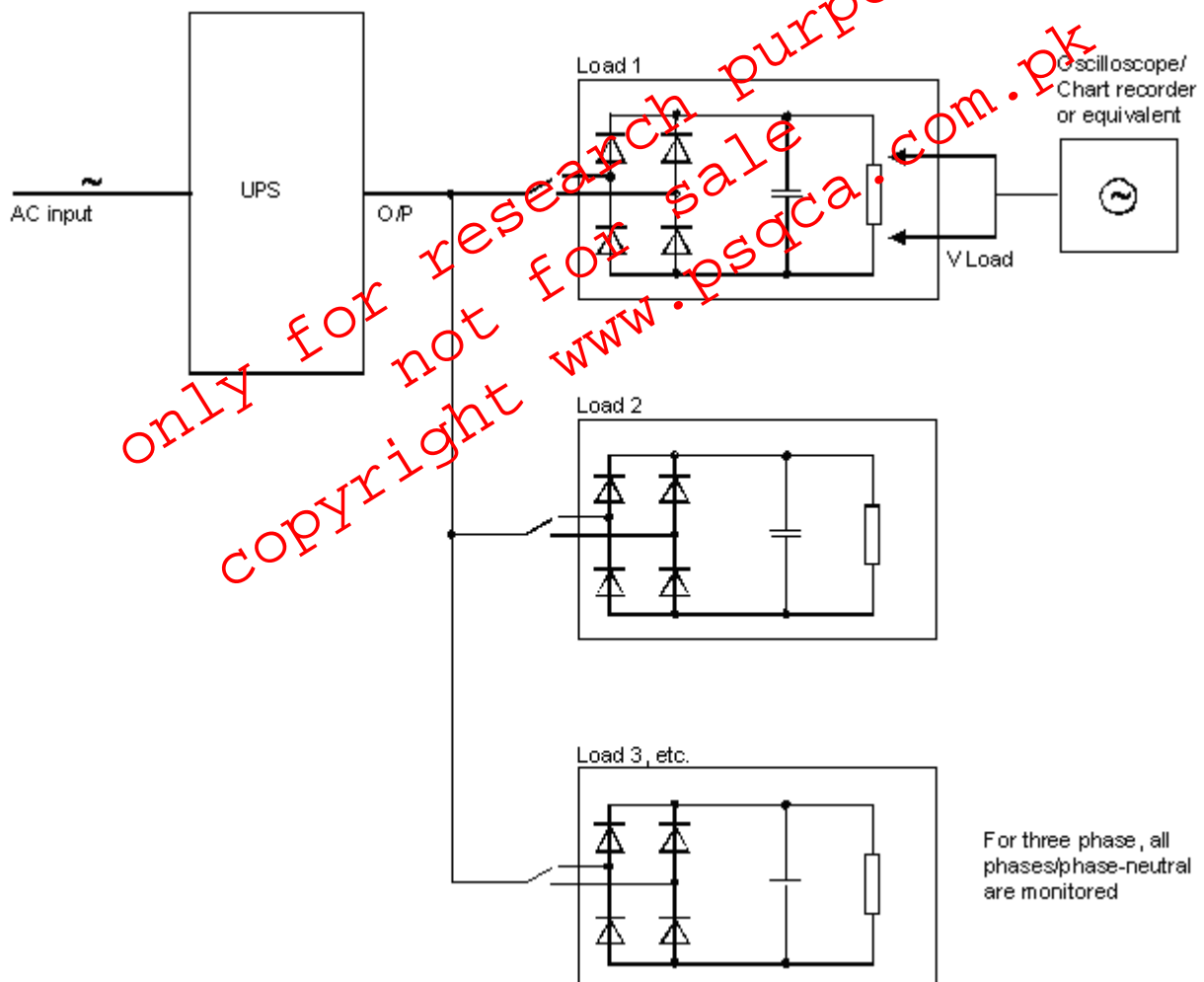

Figure 6 – Reference non-linear load test method

The capacitor voltage waveform of the non-linear load is observed to determine voltage variation and time duration of the transient.

NOTE Loads 1, 2, 3 are designed in accordance with Annex E.

Change of mode:

Using the test circuit of Figure 6, initiate the change of mode under conditions as required by the relevant test procedure. While initiating the change of mode, observe the change voltage and determine if compliance with the limits of applicable curve 1, 2 or 3 of Figure 2, 3 or 4 is achieved.

Load step:

Using the test circuit of Figure 6, apply the specific non-linear load step under conditions as required by the relevant test procedure. Observe, on a base load, the voltage deviation over time and determine if compliance with the limits of applicable curve 1, 2 or 3 of Figure 2, 3 or 4 is achieved.

6.4.4 Stored and restored energy

6.4.4.1 Stored energy time

The stored energy time shall be determined by switching off the a.c. input to the UPS operating at rated output active power and measuring the duration that the specified output power is maintained.

Assuming that the energy storage system is a battery, subject to any particular agreement between the purchaser and the UPS manufacturer, the reference temperature of the battery shall be 25 °C. The temperature of the battery bank shall be measured immediately prior to the test for the purpose of calculation of any adjustment to the expected stored energy time.

NOTE 1 Similar consideration may apply for other stored energy technologies.

The battery cut-off voltage shall not fall below the specified value before this time has elapsed.

Before carrying out this test, operate the UPS in normal mode of operation with nominal input supply and no output load applied for a period in excess of the manufacturers stated restored energy time.

Apply a linear load equal to the rated output active power and interrupt the input supply to force stored energy mode of operation.

Measure the output voltage at the beginning and end of stored energy operation. Measure the time of operation in stored energy mode until the UPS shuts down on battery end-of-discharge. Evaluate the total output voltage regulation and worst-case fundamental and harmonic levels which shall not exceed the manufacturer's declared values.

NOTE 2 Since new batteries often do not provide full capacity during a start-up period, the discharge test should be repeated after a reasonable restored energy time, if the time achieved initially is less than specified limit. A number of charge/discharge cycles may be necessary before full battery capacity is achieved.

6.4.4.2 Restored energy time (to 90 % capacity)

At the cessation of stored energy test of 6.4.4.1, reapply the input supply to the UPS and operate in normal mode of operation, at nominal input supply voltage and rated output active and apparent power. Measure maximum UPS input current at the start of restored energy time.

After the manufacturer's stated restored energy time has elapsed, the test of 6.4.4.1 shall then be repeated. Verify that the new value of stored energy time is not less than 90 % of the time previously measured.

NOTE 1 Worst-case consideration should apply where the charging capacity, in normal mode of operation, is affected by the amount of load applied to the UPS output.

NOTE 2 Stored energy and restored energy times are influenced by ambient temperature and the values stated by the manufacturer for restored energy time is the time to restore 90 % of rated capacity unless otherwise stated.

6.4.4.3 Battery ripple current measurement

The a.c. component (r.m.s. value) of the battery current shall be measured when a limit for battery ripple current is specified. The UPS shall operate in normal mode and the battery shall be fully charged. Worst-case ripple current shall be reported if this measurement is affected by the loading of the UPS. Balanced and unbalanced load conditions shall be considered.

Compliance is verified when the ripple current measured is equal or lower than that specified by the battery manufacturer.

6.4.4.4 Restart test

Automatic or other restart means shall be tested after a complete shutdown of the UPS.

6.5 Type test procedure (environmental)

6.5.1 Environmental and transportation test methods

The following test sequences are intended to simulate the environmental and transportation requirements the UPS is designed to meet.

6.5.2 Transportation

The following tests assess the construction of the UPS in the shipping container against resistance to damage by normal handling operations during transportation.

6.5.2.1 Shock test

This shall be carried out on units with mass less than 50 kg complete, but excluding the shipping container. Perform shock tests in accordance with the following.

- a) Initial measurements: perform the electrical routine tests described in 6.2.2 on the UPS and then pack it into its shipping state for transportation.
- b) Mode of operation: The UPS is non-operational and packed in its normal shipping state for transportation.
- c) Test: The packaged specimen shall be subjected, in all three planes, to two 15 g half-sine shock pulses of 11 ms nominal duration. The method of test shall be as in IEC 60068-2-27. Measurements during testing: No measurements are taken during the test.
- d) Final requirements: After the tests, the UPS shall be unpacked and checked for signs of physical damage or distortion to component parts and shall continue to function according to this standard.
- e) Final measurements: perform light load and functional test **routine test** (see 6.2.2.3).

NOTE Final measurements and requirements can be combined with those of the free fall test (see 6.5.2.2).

6.5.2.2 Free fall test

Perform free fall tests in accordance with the following.

- a) Initial measurements: perform the electrical routine tests described in 6.2.2 on the UPS.
- b) Mode of operation: The UPS is non-operational during the test and packed in its normal shipping state for transportation.

- c) Test: The specimen shall be allowed to fall freely from a point of suspension into a solid surface. The surface of the package which is caused to touch the solid surface through the fall is the surface on which the package normally rests. The method of test shall be as in IEC 60068-2-31. The following are the minimum requirements:
- 1) the test shall be carried out twice;
 - 2) the test shall be made with the specimen in its integral transport case or shipping state for transportation;
 - 3) the height of fall shall be according to Table 4;
 - 4) the height of fall shall be measured from the part of the specimen nearest to the test surface.

Table 4 – Free fall testing

Mass of unpacked specimen kg	Height of fall mm
$M \leq 10$	250
$10 < M \leq 50$	100
$50 < M \leq 100$	50
$100 < M$	25

- d) Measurements during testing: No measurement is taken during the test.
- e) Final requirements: After the test, the UPS shall be unpacked and inspected for physical damage to component parts, and the UPS shall continue to perform in accordance with the initial characteristics and meet the constructional safety requirements.
- f) Final measurements: perform light load and functional test routine test (see 6.2.2.3).

6.5.3 Storage

Perform storage tests in accordance with the following

- a) Initial measurements: Perform the electrical routine tests described in 6.2.2 on the UPS. Before carrying out these tests, any internal battery shall have been charged for the period defined in the manufacturer's instructions and be in a state of full charge.
- b) Mode of operation: The UPS is not operational, but packed in its normal shipping state for transportation and storage with controls set in shipping state.
- c) Tests:
 - 1) Dry heat as per the normal environmental conditions: $+55\text{ °C} \pm 2\text{ °C}$ for a duration of 16 h using the test method Bb of IEC 60068-2-2.
 - 2) Damp heat as per the normal environmental conditions: $+40\text{ °C} \pm 2\text{ °C}$ at a humidity of 90 % to 95 % for a duration of 96 h using IEC 60068-2-78.
 - 3) Cold as per the normal environmental conditions: $-25\text{ °C} \pm 3\text{ °C}$ for a duration of 16 h where practicable using test method Ab of IEC 60068-2-1.
 - 4) Damp heat repeated.
- d) Measurements during test: No measurement is taken during the tests.
- e) Final requirements: After the tests, the UPS shall be unpacked and inspected for signs of damage to components or corrosion of metallic parts. The UPS shall continue to perform in accordance with the initial characteristics and meet the constructional safety requirements.
- f) Final measurements: Allow unit to return to normal ambient temperature and pressure. After tests, the UPS shall perform in accordance with the light load and functional test routine test (see 6.2.2.3).

6.5.4 Operation

Perform operation tests in accordance with the following.

- a) Initial measurements: Perform the electrical routine tests described in 6.2.2 on the UPS.
- b) Mode of operation: The UPS works in normal mode of operation at rated input voltage and rated output apparent power.
- c) Test: Tests shall be done in the following sequence:
 - 1) Dry heat as per the normal environmental conditions or as per the manufacturer's stated maximum value for a duration of 16 h using test method Bd of IEC 60068-2-2.
 - 2) Damp heat as per the normal environmental conditions: $+30\text{ °C} \pm 2\text{ °C}$ at a humidity of 82 % to 88 % for a duration of 96 h using IEC 60068-2-78.
 - 3) Cold as per the normal environmental conditions or as per the manufacturer's stated minimum temperature for a duration of 2 h using test method Ad of IEC 60068-2-1.
 - 4) Damp heat repeated.

Exceptionally, where the UPS incorporates energy storage system (s) in the form of batteries, the test temperature shall be at $+5\text{ °C}$ minimum and $+35\text{ °C}$ maximum.

- d) Measurements during testing: Measurements are taken during the tests in order to check that the UPS continues to function according to this standard in normal, stored energy and bypass modes of operation as applicable.
- e) Final measurements: Same as initial measurements.
- f) Final requirements: After the tests, the UPS shall work in accordance with the light load and functional test routine test (see 6.2.2.3) and meet applicable constructional safety requirements.

6.5.5 Acoustic noise

The manufacturer shall state in the technical documentation the acoustic noise level that shall be measured in accordance with the method of measurement specified in ISO 7779 and governed by the normal positioning expected in use (for example, table-top, wall-mounted or free-standing).

Values shall be measured when the UPS operates at rated steady-state linear load under the following conditions:

- normal mode of UPS operation, at normal input voltage;
- stored energy mode of UPS operation.

The acoustic noise level shall be referred to the 1 m distance and stated in dBA (dB referenced to acoustic weighing scale A obtained from a sound level meter complying with IEC 61672-1).

The acoustic noise from audible alarms shall not be included in the values stated.

The acoustic noise from fans required to operate under any rated condition shall be included in the values stated.

Compliance is verified when the values measured are within the values declared by the UPS manufacturer.

6.6 UPS functional unit tests (where not tested as a complete UPS)

6.6.1 UPS rectifier tests

Line-commutated rectifiers shall be tested in accordance with the applicable tests in Clause 7 of IEC 60146-1-1.

Self-commutated rectifiers shall be tested in accordance with 6.6.2.

Routine tests will cover insulation test and light load test and a checking of auxiliary protection devices and control systems.

Type tests will include additional load tests, determination of losses, temperature rise, etc.

6.6.2 UPS inverter tests

Inverter tests shall be performed in accordance with the applicable tests in Clause 7 of IEC 60146-2 that presents a schedule of routine tests, type tests and optional tests.

6.6.3 UPS switch tests

UPS switches which are regarded as integrated parts of a complete UPS and are matched to the requirements of the UPS are not tested separately.

UPS switches that are not regarded as integrated parts of a complete UPS shall be tested in accordance with their own product standard.

The UPS type test programme shall include tests to prove the rated values given in Clause 5 of this standard as far as those values are not proved by adequate calculation. If previous type tests have been performed, the original manufacturer's specifications shall be acceptable and no further tests will be required.

6.6.4 Stored energy / battery tests

Unless otherwise specified in the purchase contract, factory tests on a valve regulated **secondary battery** within a UPS or in separate UPS battery cabinets shall be limited to initial type tests and such routine production tests deemed necessary, by the UPS manufacturer, to verify the performance of the battery.

Stored and restored energy times and any additional on-site testing in accordance with shall be a matter of agreement between the UPS manufacturer or supplier, and the purchaser.

Special charging regimes, such as boost/equalization requirements required by the battery manufacturer shall be demonstrated.

Annex A (informative)

Uninterruptible power system (UPS) configurations

A.1 General

The uninterruptible power system (UPS), as described in this standard is an electronic power system. Its primary function is to provide specified continuity and quality of power to a user's equipment in the event of a partial or total failure of the normal source of power, which is usually the public low-voltage a.c. power supply system. This is accomplished by converting either power from the usual normal source and/or from some form of stored energy to supply power to the user's equipment for a specified period of time when the utility is no longer available or acceptable.

The user's equipment, typically referred to as the critical or protected load, may consist of one or many pieces of equipment located in a room or a building. This is the equipment that the user has determined needs to be provided with power that has a better continuity and quality than that power which is normally available. The critical load is predominantly some form of data processing equipment, although it may be other equipment such as lighting, instrumentation, pumps or communication equipment. The stored energy to support this load, usually in the form of batteries, may be needed to supply power to the equipment for a specified time which may be momentary or for many hours. The time interval is commonly referred to as stored energy time or back-up time.

A variety of UPS have been developed to meet the user's requirements for continuity and quality of power to different types of loads over a wide range of power from less than one hundred watts to several megawatts.

The following text outlines the variation of UPS configurations ranging from a single unit to more complex systems for added availability of load power.

Various UPS configurations are used to achieve different degrees of availability of load power and/or to increase output power rating.

This annex presents the characteristics of typical arrangements in use.

A.2 Single output bus UPS

A.2.1 General

A single UPS comprises a stored energy source and one or more static power converter(s) e.g. a rectifier/battery charger and an inverter and performs in accordance with UPS manufacturer's declaration (see 5.3.4). A single UPS generally presents an availability consistent with equipment requiring reliability integrity level 1 (RIL-1 - see Annex K).

A.2.2 Basic single UPS

A basic single UPS is a UPS unit that contains no alternative circuit path for the purpose of ensuring **continuity of load power**. See Figure A.1.

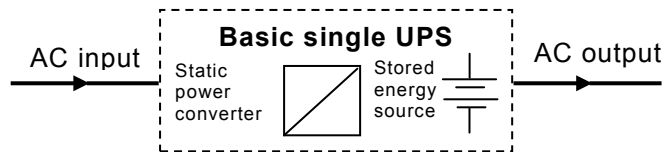

Figure A.1 – Single UPS – Basic

In the case of an a.c. input power failure, the stored energy source, e.g. a battery, will supply the power at a decreasing d.c. voltage until it is too low for satisfactory output of the inverter. The type and capacity of the battery will determine the length of time the system can operate without an a.c. input supply.

NOTE 1 Double-conversion, line-interactive and stand-by UPS topologies, as detailed in Annex B, represent examples of a basic single UPS.

NOTE 2 It is acknowledged that some applications require, in addition to the a.c. output, a source of uninterruptible d.c. power. Subject to an agreement between the UPS manufacturer and the purchaser, the d.c. power may be derived from the d.c. link. Such d.c. requirements are excluded from the scope of this standard.

A.2.3 Single UPS with bypass

A single UPS with bypass, see Figure A.2 is a basic single UPS to which an alternative (bypass) circuit path is added for the purpose of ensuring **continuity of load power** upon:

- failure of the basic single UPS,
- load current transients (overload, inrush or fault currents) exceeding those of the basic single UPS and not exceeding those of the bypass.

Subject to compatibility of the a.c. input source with the requirements for a.c. output, the addition of a bypass increases the availability of load power.

The physical implementation of the bypass may consist of semiconductors (e.g. thyristor, triac, transistors) and/or of electro-mechanical devices (e.g. relay, contactor), provided that the bypass control and activation design is compatible with the requirements specified for the UPS (see Clause 5).

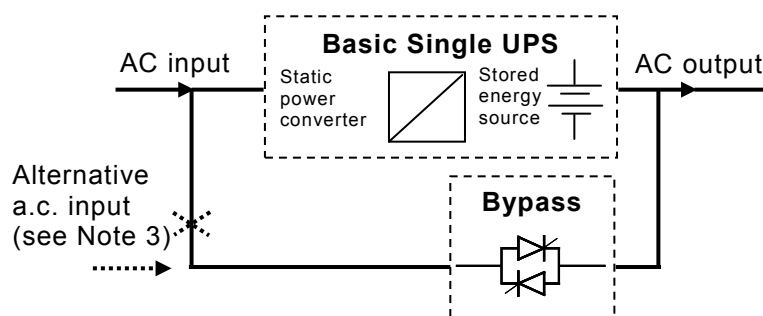

NOTE 1 The input and output frequency is normally the same and, if the voltage levels are different, a bypass transformer is used. For some loads, the UPS and the bypass a.c. input are synchronized to maintain **continuity of load power**.

NOTE 2 A UPS **interrupter** is used to connect or disconnect the basic single UPS to or from the a.c. output.

NOTE 3 Split a.c. input design can be used subject to compatibility requirements, if any, to be disclosed by the UPS manufacturer.

NOTE 4 An overall **maintenance bypass switch** can be added to the bypass for servicing purposes.

NOTE 5 The use of bypass introduces the possibility of an a.c. input disturbance affecting the load.

Figure A.2 – Single UPS with bypass

A.3 Parallel UPS

A parallel UPS comprises two or more single UPS units whose a.c. outputs, in normal mode of operation, are connected to a common a.c. output bus.

NOTE UPS **interrupters** may be used in parallel UPS applications to connect or disconnect UPS units to or from the common a.c. output bus (see Annex C).

The total quantity of single UPS units in a parallel UPS equals “n + r” where

n is the quantity of single UPS units required to support the load;

r is the quantity of redundant UPS units.

A parallel redundant UPS contains at least one redundant UPS unit (“n + 1”) and presents an availability higher than that of the single UPS corresponding because any UPS unit may be isolated in case of failure and for maintenance procedures without affecting the continuity of power to the load.

A parallel capacity UPS contains no redundant UPS module UPS unit (“n + 0”) and presents an availability lower than that of the single UPS corresponding because the failure of any module may affect the continuity of power to the load.

A.3.1 Parallel UPS with common bypass

This configuration consists of a paralleled basic single UPS with one common overall bypass fitted. See Figure A.3.

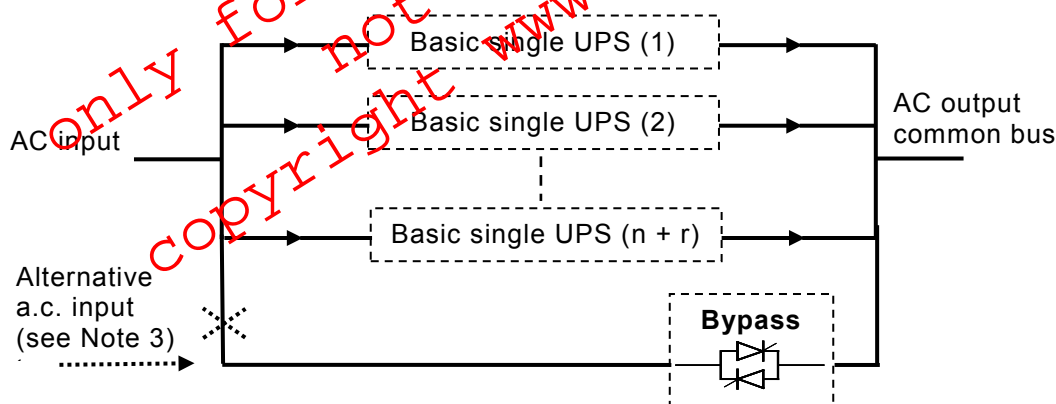

NOTE Notes 1 to 5 of Figure A.2 apply.

Figure A.3 – Parallel UPS with common bypass

A.3.2 Parallel UPS with distributed bypass

This configuration consists of paralleled UPS with bypass designed to ensure that, when the UPS operates in bypass mode; the rated load current flows through the distributed bypass units without overloading any of them. See Figure A.4.

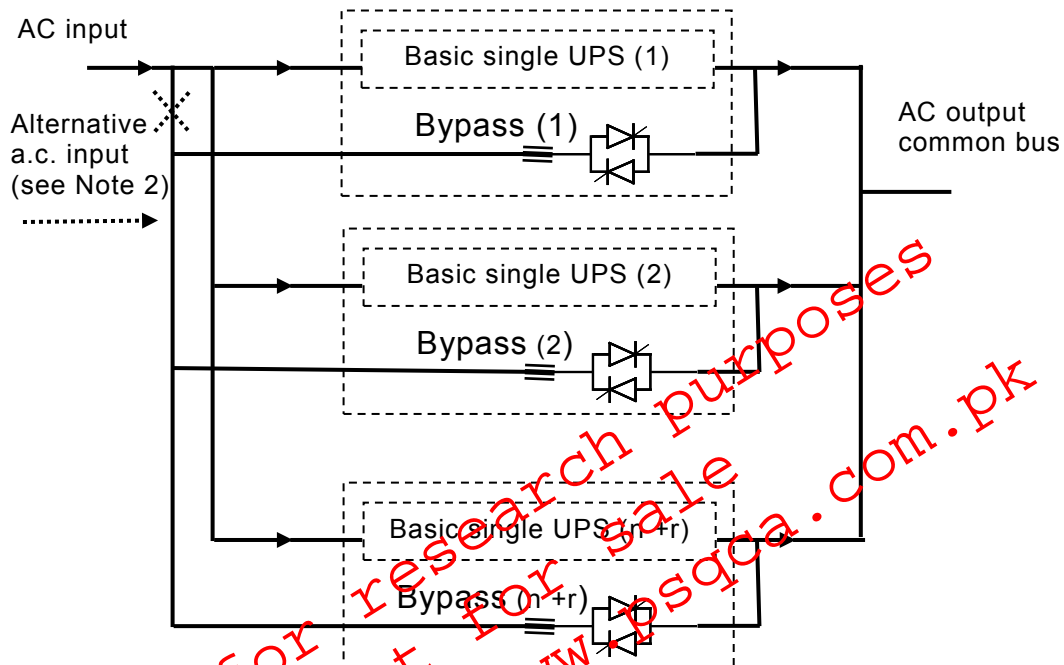

NOTE Notes 1 to 5 of Figure A.2 apply.

Figure A.4 – Parallel UPS with distributed bypass

A.3.3 Stand-by redundant UPS

The stand-by redundant UPS configuration comprises a minimum of two single UPS with bypass configuration. The bypass input of the working UPS (that supplies power to the critical load), is fed by the a.c. output of the idling UPS. Usually the basic single UPS of the working UPS supplies power to the load and transfers the load to the idling UPS in case of failure of the working UPS. See Figure A.5.

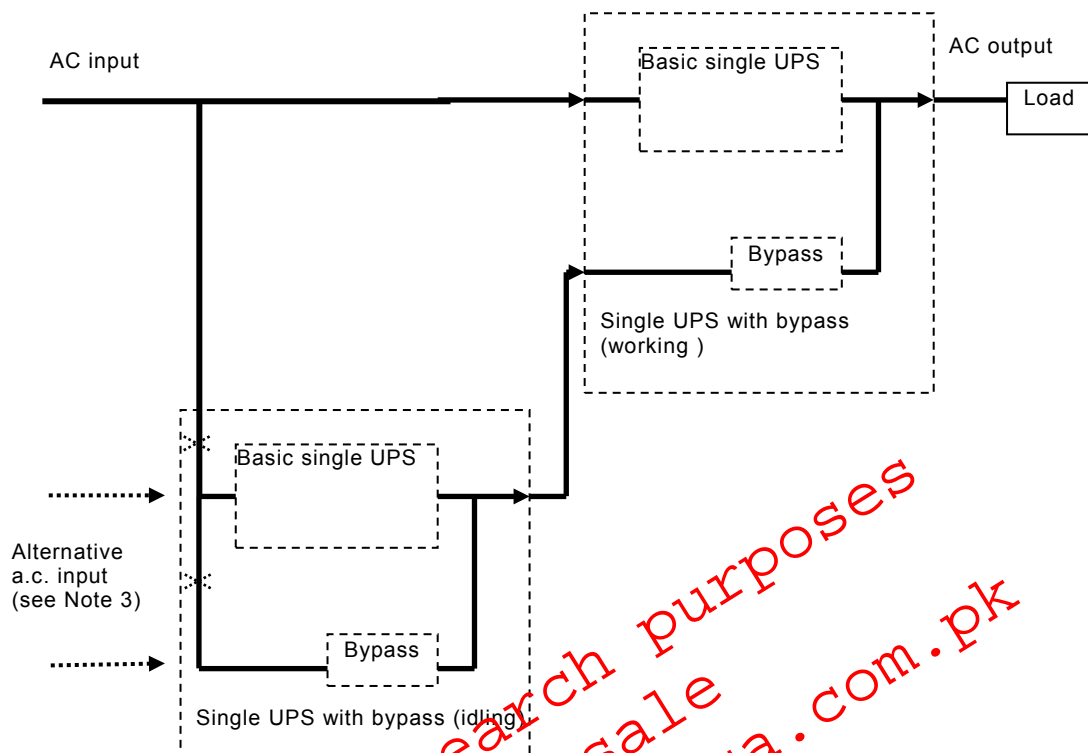

NOTE Notes 1 to 5 of Figure A.2 apply.

Figure A.5 – Stand-by redundant UPS

A variation of the stand-by redundant UPS configuration consists of two or more working UPS connected to one idling UPS.

A.4 Dual bus UPS

A.4.1 Basic dual bus UPS

A basic dual bus UPS comprises any two UPS configurations of this annex whose a.c. outputs are connected to separate buses. See Figure A.6.

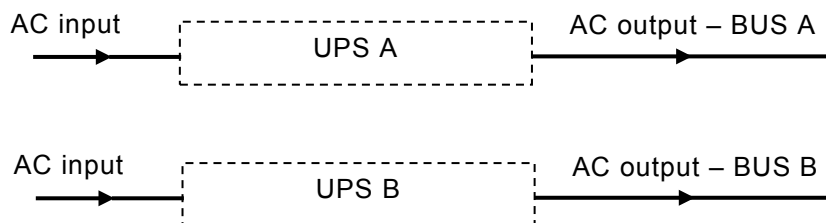

NOTE Notes 1 to 5 of Figure A.2 apply.

Figure A.6 – Dual bus UPS

Dual bus configuration is primarily intended to supply loads that accept dual input supply.

A basic dual bus configuration UPS is normally designed with redundancy so that any of the two buses is capable of supplying the total load ("2n"). The redundant dual bus UPS presents an availability higher than that corresponding a parallel redundant UPS configuration with the same quantity of UPS units. This is a result of the fault tolerant a.c. output configuration where in addition to supply redundancy; a fault on one bus does not affect the other bus.

NOTE Dual bus configuration requires duplicated supply wiring to the load.

A.4.2 Stand-by redundant dual bus UPS

Dual bus configuration intended to supply loads that accept only a single input supply may be implemented with the use of a fault tolerant transfer system. The transfer system ensures that power from only one of the two buses is supplied to the load and transfers the load to the idling bus in case of a source initiated failure. See Figure A.7. See 5.5 for references to transfer systems.

NOTE Some loads require UPS A and UPS B to be synchronized for the purpose of maintaining continuity supply transfer.

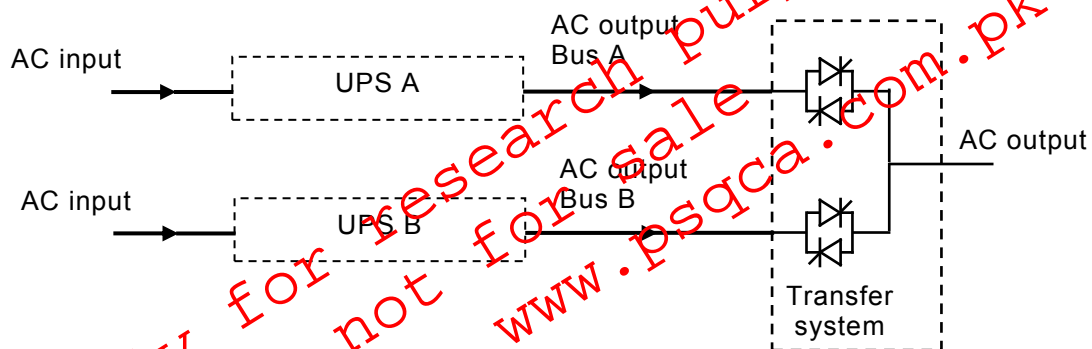

Figure A.7 – Stand-by redundant dual bus UPS

Annex B (informative)

Topologies – Uninterruptible power system (UPS)

B.1 General

This annex describes popular UPS topologies in use and the mode of operation of each of these in form of a block diagram. The stored energy source is commonly a battery and has been symbolised as such throughout this annex. But other forms of stored energy sources are equally possible. See 5.4.1.

Additional circuits and components such as filters (transient and EMC) and isolation transformers may be required depending on the topology, the load requirements and the a.c. power distribution system. These details are omitted for simplicity. The technical merits are not discussed and the purchaser should verify with the vendor the suitability of any system for the intended load equipment.

B.2 Double conversion topology

Double-conversion topology comprises an a.c. to d.c. converter, generally a rectifier, and a d.c. to a.c. converter, generally an inverter. See Figure B.1.

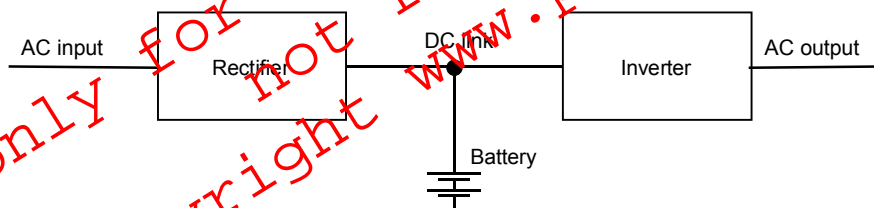

Figure B.1 – Double conversion topology

In normal mode of operation, the load is continuously supplied by the rectifier/inverter combination.

The d.c. link may be directly connected to the stored energy source or through a d.c. to d.c. converter, a switch or a semiconductor. Recharge of the stored energy source may be provided by the rectifier or by other means e.g. by a dedicated charger.

When the a.c. input supply is out of UPS preset tolerances, the UPS enters stored energy mode of operation where the battery/inverter combination continues to support the load for the duration of the stored energy time or until the a.c. input returns to UPS design tolerances, whichever is the sooner.

NOTE 1 The double-conversion topology is often referred to as an “on-line UPS” meaning the load is always supplied by the inverter irrespective of the condition of the a.c. input supply. The term “on-line” also means “on-the-mains”. To prevent confusion in definition, the term “on-line” should be avoided and the term “double-conversion” used.

NOTE 2 A double-conversion UPS is an example of a UPS providing VFI performance (see 5.3.4).

B.3 Line-interactive topology

Line-interactive topology comprises a bi-directional a.c. to d.c. converter, generally a bi-directional inverter and an a.c. power interface. See Figure B.2.

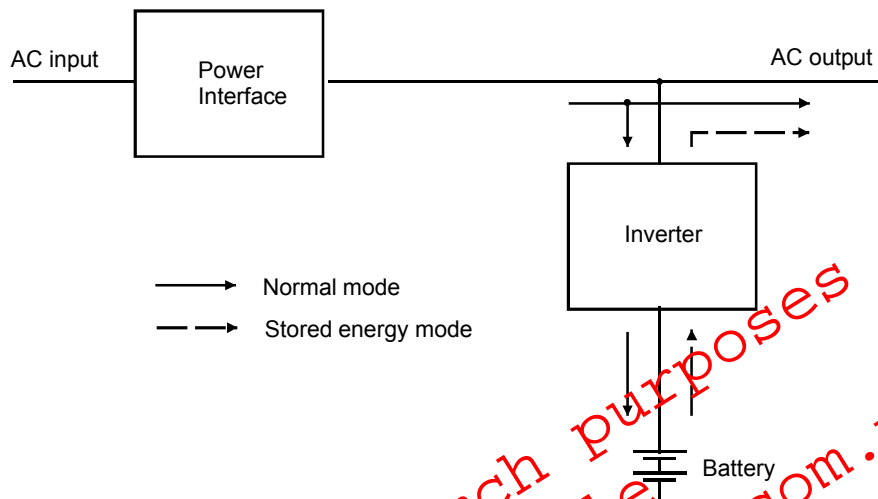

Figure B.2 – Line-interactive topology

In normal mode of operation, the load is supplied with conditioned power via a parallel connection of the a.c. input and the UPS inverter. The inverter or the power interface is operating to provide output voltage conditioning and/or battery charging. The output frequency is dependent upon the a.c. input frequency.

When the a.c. input supply voltage or frequency is out of UPS preset tolerances, the inverter and battery maintain **continuity of load power** in stored energy mode of operation and the switch disconnects the a.c. input supply to prevent backfeed from the inverter.

The unit runs in stored energy mode for the duration of the stored energy time or until the a.c. input supply returns within UPS design tolerances, whichever is the sooner.

NOTE 1 The nature of this design requires an impedance between the a.c. input power and the inverter.

NOTE 2 The inverter may be of bidirectional design as described above and the a.c. input power interface may consist of a passive impedance. Alternatively, the inverter may be unidirectional and the a.c. input power interface may consist of a power conditioner. In this case, a separate energy storage charger is incorporated.

NOTE 3 A line-interactive UPS is an example of a UPS providing VI performance (see 5.3.4).

B.4 Stand-by topology

Stand-by topology comprises a battery charger, a d.c. to a.c. converter, generally a unidirectional inverter and a UPS switch. See Figure B.3.

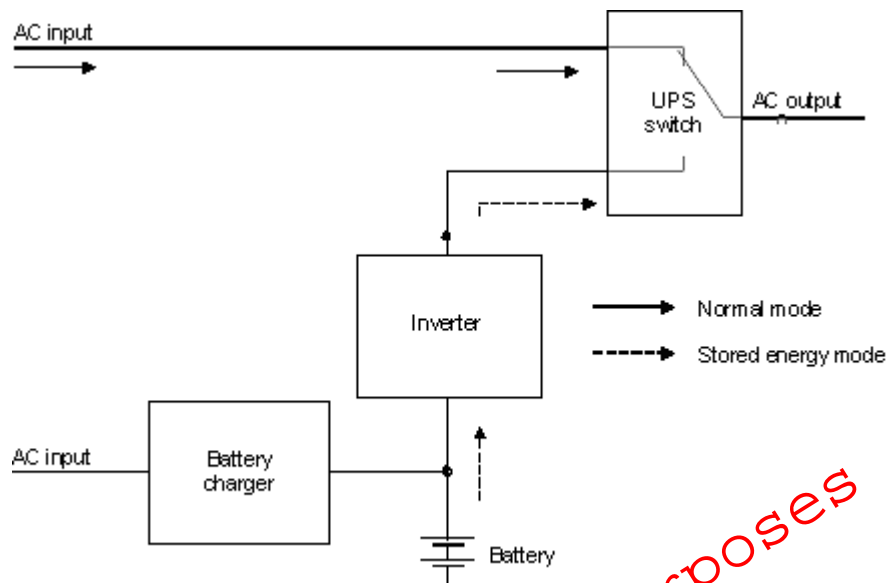

Figure B.3 – Stand-by topology

In normal mode of operation, the load is supplied with a.c. input power via the UPS switch. When the a.c. input supply is out of UPS preset tolerances, the UPS unit enters stored energy mode of operation, and the load is transferred to the inverter directly or via the UPS switch.

The battery/inverter combination maintains **continuity of load power** for the duration of the stored energy time or until the a.c. input supply returns to within UPS preset tolerances and the load is transferred back, whichever is the sooner.

In active stand-by operation, the inverter is normally operating at no load.

In passive stand-by operation, the inverter is normally not operating but activated upon a.c. input failure.

NOTE 1 Stand-by topology is often referred to as an “off-line UPS”, meaning electronically conditioned power is fed to the load only when the a.c. input supply is out of tolerance. The term “off-line” also means “not-on-the-mains” when in fact the load is fed from the mains in normal mode of operation. To prevent confusion, the term “off-line” should be avoided and the term “passive stand-by” used.

NOTE 2 The UPS transfer switch may be electro-mechanical or electronic (see Clause C.2) depending on the load requirements.

NOTE 3 A stand-by UPS is an example of a UPS providing VFD performance (see 5.3.4).

NOTE 4 Incorporation of additional devices to provide conditioning of the a.c. input e.g. a ferro-resonant transformer or an automatic tap-changer, turns a passive stand-by UPS into a line-interactive UPS.

Annex C (informative)

UPS switch applications

C.1 General

This annex describes the general characteristics and applications of UPS switches that are integral to a UPS.

UPS switches, as defined in 3.1, include interrupters, transfer switches, bypass switches, isolation switches and tie switches. These switches interact with other functional units of the UPS for the purpose of maintaining **continuity of load power** under prescribed conditions, including fault and maintenance conditions. Other switches or breakers, encountered in conventional mains distribution boards, such as rectifier input switches, battery disconnect switches and general purpose breakers or switches are not included in this discussion.

NOTE 1 Stand-alone static transfer systems (STS) that are not integral part of a UPS are excluded from the scope of this standard. STS test and performance requirements are covered in IEC 62310-3.

NOTE 2 The UPS switches shown in the diagrams of this annex are represented as separate units. In practice, a UPS switch may be contained within a UPS unit.

C.2 Interrupters

An interrupter (INT) connects or disconnects the output of a UPS unit to or from a load bus. See Figure C.1.

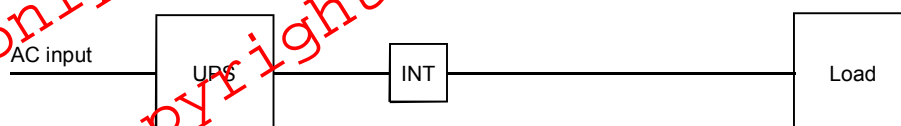
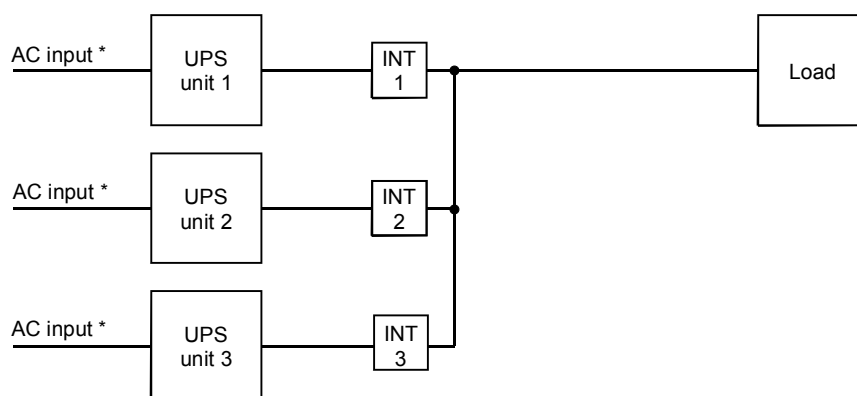

Figure C.1 – UPS interrupter

UPS interrupters may be used in parallel UPS applications (see Figure C.2) to connect or disconnect UPS units to or from a common bus. The interrupters enable operating UPS units to remain connected to the load and failed UPS units to be instantly disconnected from the load so as not to disturb the quality of the load power.



* AC inputs may be tied.

Figure C.2 – UPS interrupters in parallel UPS application

UPS interrupters may also be used to connect or disconnect one or more load branches to or from a common bus. See Figure C.3.

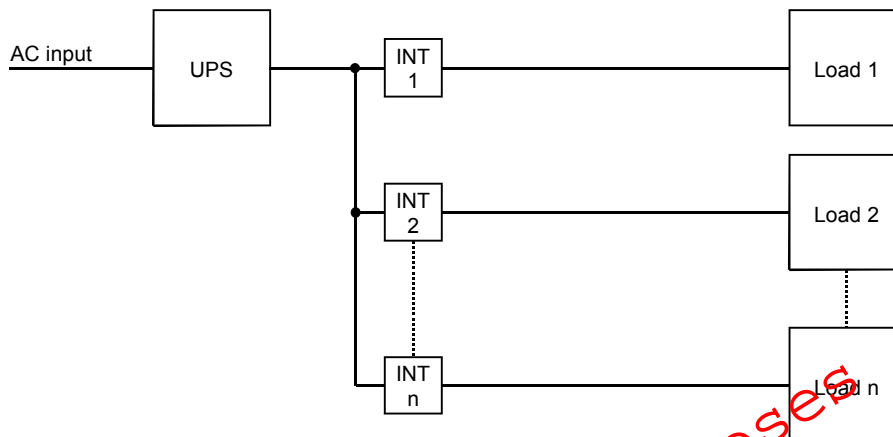

Figure C.3 – UPS interrupters in split load application

NOTE 1 An **interrupter** may be constructed with a

- **electronic power switch** – providing very fast opening and closing times;
- **mechanical power switch** – providing air-gap isolation when open and high overload capacity when closed;
- **hybrid power switch** – providing very fast closing time and high overload capacity when closed.

NOTE 2 In some UPS designs, the inverter's electronic switching devices (valves), normally used for d.c. to a.c. power conversion, are also used as an interrupter.

C.3 Transfer switches, bypass transfer switches

A transfer switch (TRA) connects the load either to the output of a UPS or to an alternative supply, e.g. the **bypass**. A transfer switch typically employs two **electronic power switches** (EPS). See Figure C.4.

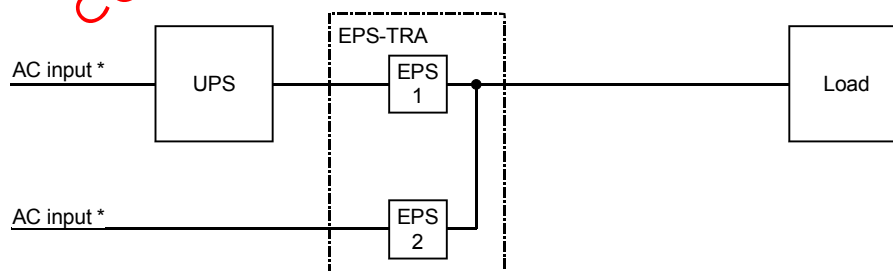

* AC inputs may be tied.

Figure C.4 – Bypass transfer switch

A bypass transfer switch is used to protect the load against power disturbances or interruption arising from inrush or fault currents that would otherwise overload the UPS or from unavailability of power during UPS failure or maintenance.

NOTE 1 Depending on the conditions prior to a transfer occurring, either **synchronous transfer** or **asynchronous transfer** occurs.

NOTE 2 **Transfer switches** can be constructed with

- **electronic power switches** – very fast opening and closing times;
- **mechanical power switches** – air-gap isolation when open and high overload capacity when closed;
- **hybrid power switches** – very fast closing time and high overload capacity when closed.

C.4 Isolation switches

UPS **isolation switches** are used to isolate electronic UPS switches from power sources for maintenance purposes. Figures C.5 and C.6 show examples of discrete UPS isolation switches. Figure C.7 shows an example of an isolation switches with interrupter function.

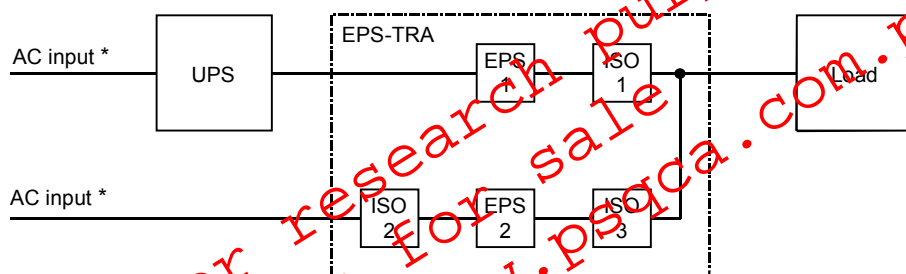

* AC inputs may be tied

Figure C.5 – Isolation of bypass transfer switch

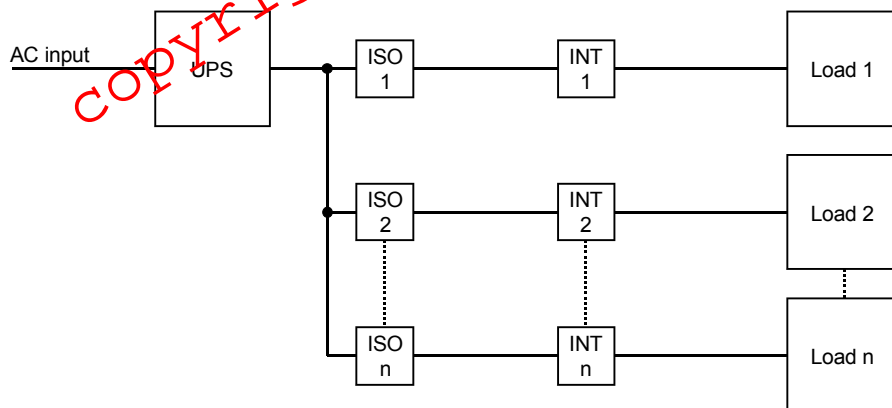

Figure C.6 – Isolation of interrupters

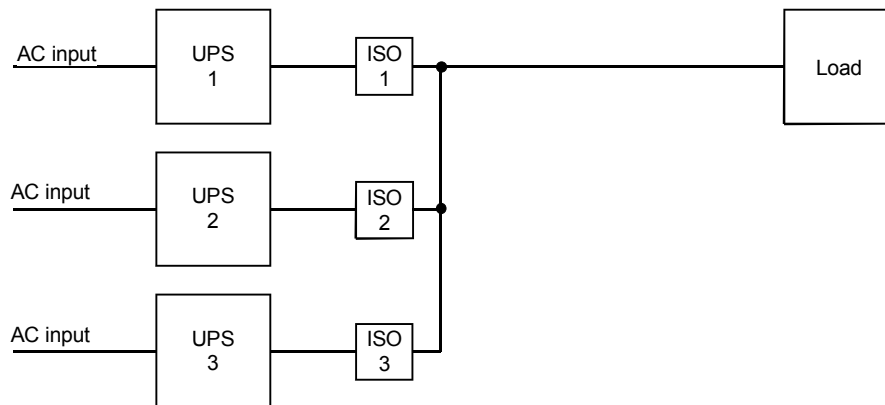
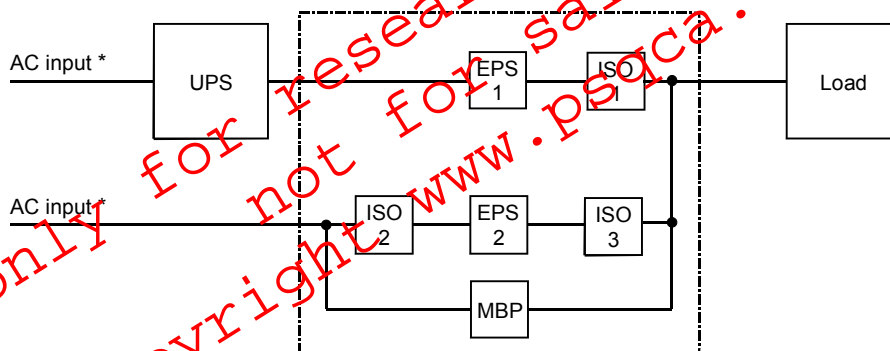

Figure C.7 – Isolation switches with interrupter function

C.5 Maintenance bypass switches

A UPS **maintenance bypass switch** is used to bypass the transfer switch and to ensure the **continuity of load power**. Figures C.8 and C.9 show examples of UPS maintenance bypass switches.



* AC inputs may be tied.

Figure C.8 – Internal maintenance bypass switch

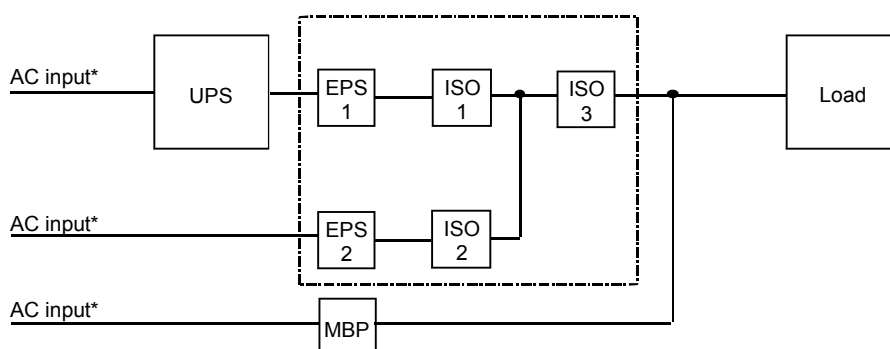

* AC inputs may be tied.

Figure C.9 – External maintenance bypass switch

C.6 Tie switches

UPS **tie switches** are typically used to connect two or more UPS output buses to two or more load buses in such a way as to permit a flexible system reconfiguration, especially during maintenance of dual bus systems. In Figure C.10, assuming that the UPS unit has sufficient capacity, the tie switch permits supply of both loads from one UPS when the other is unavailable. A similar principle applies to Figure C.11.

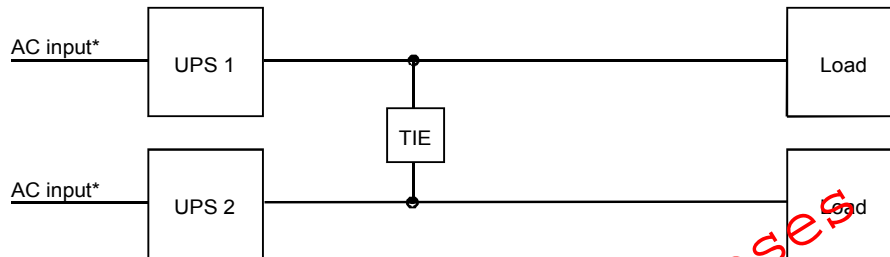

* AC inputs may be tied.

Figure C.10 – Tie switch in dual bus application

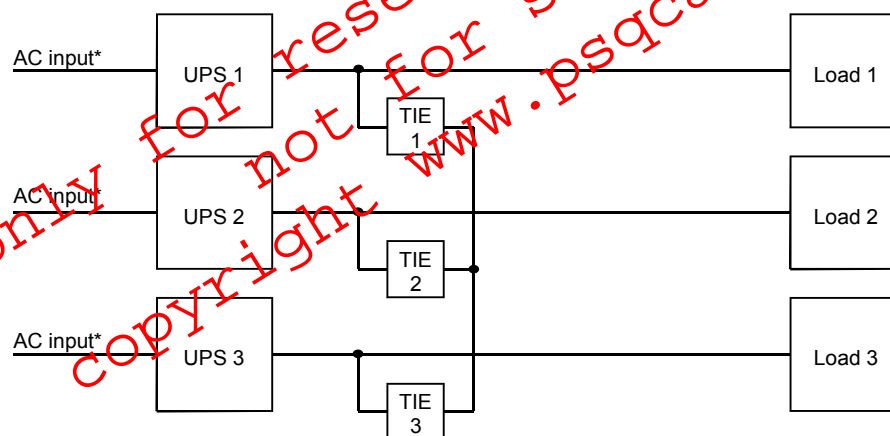

* AC inputs may be tied.

Figure C.11 – Tie switches in triple bus application

C.7 Multiple function switches

UPS switches can be combined to perform multiple functions. Figure C.12 illustrates a parallel redundant UPS with a bypass transfer switch combined with two interrupters that may also be isolation switches.

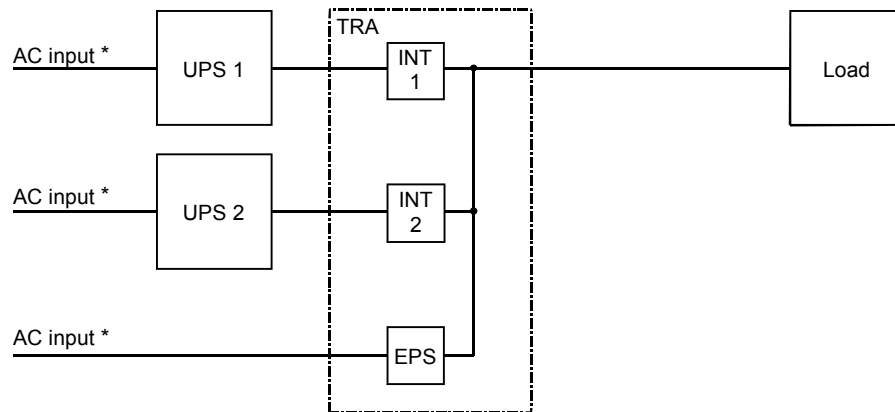

* AC inputs may be tied.

Figure C.12 – Multiple function bypass, interrupter and isolation switch

only for research purposes
not for sale
copyright www.psqca.com.pk

Annex D (informative)

Purchaser specification guidelines

D.1 General

A variety of UPS are available to meet the user requirements for continuity and quality of power to different types of loads over a wide range of power from less than one hundred watts to several megawatts.

This annex has been compiled to assist purchasers to formalise criteria important to their application and/or to confirm agreement with conditions declared by the manufacturer/supplier.

For an explanation of typical UPS configurations, modes of UPS operation and topologies, the reader's attention is drawn to Annexes A, B and C.

The "UPS technical data sheet" contained in this annex presents a summary of the normal and unusual environmental and electrical conditions to be considered. This data sheet also references the specific subclause of concern. The reader's attention is drawn to Clauses 4 (environmental conditions) and 5 (electrical conditions).

The following additional topics should also be considered.

D.2 Load to be supplied by the UPS

The diversity of types of load equipment and their relevant characteristics are always changing with technology. For this reason, the UPS output performance is characterized by loading with passive reference loads to simulate, as far as practical, the expected load types, but it cannot be taken that these are totally representative of the actual load equipment in a given application.

The UPS industry has generally specified UPS output characteristics under conditions of linear loading, i.e. resistive or resistive/inductive. Under present technology, many loads present a non-linear characteristic due to power supplies of the rectifier capacitor type either single or three-phase (see Annex E).

The effect on the output of the UPS by non-linear loads both in steady-state and dynamic is, in many cases, to cause deviation from the output characteristic specified by the manufacturer/supplier where these are quoted under linear load conditions.

Due to the higher peak to r.m.s. steady-state current ratios, the output voltage total harmonic distortion may be increased beyond the stated limit. Compatibility with the load for higher levels of THD is a matter of agreement between the manufacturer/supplier and the purchaser.

Application of non-linear load steps may result in a deviation from the linear dynamic voltage characteristics due to high transient inrush currents relative to steady-state, especially where the UPS employs electronic current limiting in normal mode of operation.

These effects of high transient inrush currents on the load voltage may be tolerable where these loads are the first to be energized or have no deteriorative effect on the loads already connected. This effect applies to switching of transformers or other magnetic devices subject to magnetic remanence and to loads containing capacitors.

Some UPS topologies use the a.c. input supply/bypass for this purpose to permit economic sizing of the UPS system. Equally, while single units may not tolerate these load steps within the specification, in multi-module or redundant systems, the total system can tolerate such load steps.

Where the load is sensitive to frequency variation beyond normal mains limits or is sensitive to voltage variation or distortion of the supply waveform, the choice of the best UPS topology for these applications should be investigated.

The advice of the manufacturer/supplier should be sought in respect of these matters.

Examples of loads that should be identified by the purchaser include, IT equipment in general; motors; saturating transformer power supplies; diode rectifiers; thyristor rectifiers; switched mode power supplies.

Examples of special features or requirements of loads include their operating duty, any unbalance between phases, non-linearity (generation of harmonic currents), branch-circuit fuse and breaker ratings, maximum step load and load profile, required method of connection of loads to UPS output.

D.3 Stored energy device (battery – where applicable)

The energy storage system is generally recommended by the manufacturer/supplier for compatibility with the UPS design. The purchaser may nevertheless identify requirements related to the following:

- a) type of battery/batteries and construction;
- b) nominal voltage, number of cells, ampere hour capacity (if supplied by purchaser);
- c) rated stored energy time;
- d) rated restored energy time;
- e) battery service life required;
- f) presence of other loads on battery and their voltage tolerances;
- g) availability of separate battery rooms;
- h) battery protection and isolation devices;
- i) special requirements regarding, for example, ripple current;
- j) temperature of battery room installation (recommended 20 °C to 22 °C);
- k) battery cut-off voltage;
- l) temperature compensated charging voltage/boost or equalization requirements.

D.4 Physical and environmental requirements

If physical and environmental requirements are other than those of Clauses 4 and 5 in this standard, the purchaser should specify:

- a) efficiency at specified load conditions;
- b) ambient temperature range of operation;
- c) cooling system (UPS and battery installation);
- d) instrumentation (local/remote);
- e) remote control and monitoring system (RS232, etc.);
- f) special environmental conditions: equipment exposed to fumes, moisture, dust, salt, air, heat, etc.;

- g) special mechanical conditions: exposure to vibration, shocks or tilting, special transportation, installation or storage conditions, limitations to space or weight;
- h) performance limitations regarding, for example, electrical and audible noise;
- i) future extensions of the UPS system.

D.5 Electromagnetic compatibility

If EMC requirements are other than those of IEC 62040-2 EMC for UPS, the purchaser should specify:

- a) required emission standards and level category to which the equipment shall comply;
- b) applicable immunity standards and test level to which the equipment shall comply.

D.6 UPS Technical data sheet – Manufacturer's declaration

Table D.1 – UPS technical data – Manufacturer's declaration

IEC 62040-3 Subclause (except if otherwise noted)	Declared characteristics General	Manufacturer's declared values	Purchaser's identified values
	Model (manufacturer's reference)		
	Power , rated	- apparent VA	
		- active W	
5.1.1	UPS configuration		
5.3.4	Performance classification		
	Mechanical		
	Dimensions (height × width × depth)	mm	
	Mass	kg	
	Mass with batteries (if integrated)	kg	
6.5.5	Acoustic noise at 1 m:	- Normal mode dBA	
		- Stored energy mode dBA	
	Safety		
IEC 62040-1	Access (operator access or restricted access)		
	Degree of protection against hazards and water ingress	IP	
	Electromagnetic compatibility		
IEC 62040-2	Emission	UPS Cat	
	Immunity	UPS Cat	
	Environmental		
4.2.1.1	Ambient temperature range	°C	
	Relative humidity range	%	
4.2.1.2	Altitude	m	
4.3	Additional or unusual conditions		
5.6	Communication circuits		
	(List communication / signalling circuits)		
			(continued)

Table D.1 (continued)

IEC 62040-3 Subclause (except if otherwise noted)	Declared characteristics Output (Electrical)	Manufacturer's declared values	Purchaser's identified values
5.3.2	AC power distribution system -compatibility (TN, TT, IT)		
	- phases available (1,2 or 3)		
	- neutral available (yes / no)		
	Voltage (steady state, r.m.s.) - rated	V	
	- normal mode variation	%	
	- stored energy mode variation	%	
	Total harmonic distortion, 100 % load -normal mode - linear	%	
	Non-linear	%	
	- stored energy mode, linear	%	
	Non-linear	%	
	Voltage unbalance and phase displacement, 100 % load unbalance	% °	
	Voltage transient and recovery time, 100 % step load linear	%, s	
	- Non-linear	%, s	
6.4.2.11.1/2	- transfer normal mode / storage energy mode	%, s	
	Frequency (steady state) - rated	Hz	
	- normal mode variation	%	
	- stored energy mode variation	%	
	- free-running variation	%	
	Synchronization (max ± % range of rated frequency)	%	
	Max synch phase error (referred to a 360° cycle)	°	
	Max slew-rate	Hz/s	
	Current (r.m.s.) - rated	A	
5.3.2.1	- Overload capability (% of rated current / time duration)	% / s	
	- Limitation (% of rated current / time duration)	% / s	
6.4.2.10.3 /4	- Fault clearing capability (normal / stored energy mode)	A gL fuse	
	Load power factor - rated		
	- displacement (permissible lead-lag range)		
5.3.2 r) / 6.4.1.6	AC / a.c efficiency in normal mode - 100 % load	%	
5.3.2 r) / 6.4.1.6	- 75 % load	%	
5.3.2 r) / 6.4.1.6	- 50 % load	%	
5.3.2 r) / 6.4.1.6	- 25 % load	%	
	Bypass – automatic (static or electro-mechanical)		
	Transfer time break	ms	
	rated current	A	
5.3.2.1	Overload current (% of rated current / time duration)	% / s	

Table D.1 (continued)

IEC 62040-3 Subclause (except if otherwise noted)	Declared characteristics Output (Electrical)	Manufacturer's declared values	Purchaser's identified values
	- maintenance (internal or external)		
	- isolation transformer (yes / no)		
	Bypass protection fuse or circuit breaker rating		
5.5	Stand-alone switch (list any and its product standard)		
5.3.3	Additional or unusual conditions		
			(continued)

only for research purposes
not for sale
copyright www.psqca.com.pk

Table D.1 (continued)

IEC 62040-3 Subclause (except if otherwise noted)	Declared characteristics Input (Electrical)	Manufacturer's Declared values	Purchaser's Identified values
5.2.1.a	Voltage (steady-state, r.m.s) - rated	V	
5.2.1.b	- tolerance	%	
5.2.1.c	Frequency - rated	Hz	
5.2.1.d	- tolerance	%	
5.2.2.c	Current r.m.s. – rated (with the energy storage device charged)	A	
5.2.2.f	maximum (with low input volt and energy storage device charging)	A	
5.2.2.h	- total harmonic distortion (THD p.u.)	%	
5.2.2.g	- overload (% of rated current against time)	%, s	
5.2.2.e	- in-rush (% of rated current against time)	%, s	
5.2.2.d	power factor		
5.2.2.k	AC power distribution system - (TN, TT, IT) compatibility		
5.2.2.i	- short circuit power required	Ssc	
5.2.2.a	- phases required (1,2 or 3)		
5.2.2.b	- neutral required (yes / no)		
5.2.3	Additional or unusual conditions		
			(continued)

Table D.1 (continued)

IEC 62040-3 Subclause (except if otherwise noted)	Declared characteristics Battery / stored energy device		Manufacturer's Declared values	Purchaser's Identified values
5.4.2.2 d	Technology			
5.4.2.2 a	Life	Design life or	years	
		float service life		
5.4.2.2 b	Quantity of cells and strings			
5.4.2.2 c	Nominal voltage (total)		V d.c.	
5.4.2.2 e	Nominal Ah capacity (C10)		Ah	
5.4.2.2 f	Stored energy time (back-up time at 100 % rated load)			
5.4.2.2 g	Restored energy time (recharge time to 90 % capacity)			
5.4.2.2 h	Ambient reference temperature		°C	
5.4.2.2 i	Earth condition / Isolation			
5.4.2.2 j	r.m.s. ripple current		%	
5.4.2.2 k	Nominal discharge current		A	
5.4.2.2 l	Fault current rating		A d.c.	
5.4.2.2 m	Cable volt drop recommendation (\leq % at nominal discharge current)		%	
5.4.2.2 n	Protection requirements by others			
5.4.2.2 o	Charging regime			
5.4.2.2 p	Charge voltage (float, boost) and tolerance band		V d.c.	
5.4.2.2 q	End of discharge voltage		V d.c.	
5.4.2.2 r	Charge current limit (or range)		A d.c.	
5.4.2.3	Additional or unusual conditions			
				(end)

Annex E (normative)

Reference non-linear load

E.1 General

Non-linear load tests prescribed in this standard require each output phase of the UPS to be connected to a reference non-linear load as shown in Figure E.1 (or to a condition in which the UPS delivers such resulting output characteristics). This circuit contains a diode rectifier bridge that has a capacitor and a resistor in parallel on its output. The physical implementation of this circuit may consist of multiple circuits in parallel.

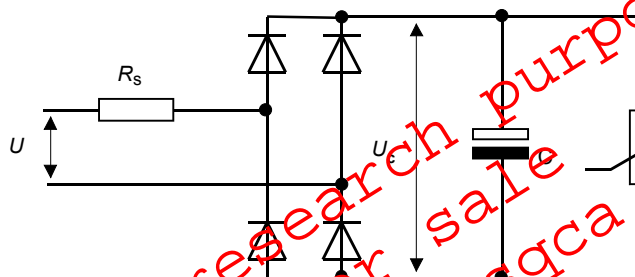

Key Refer to Clause E.4 for description of U , R_s , R , C , U_c .

NOTE Resistor R_s may be placed either on the a.c. or d.c. side of the rectifier bridge.

Figure E.1 – Reference non-linear load

E.2 Apparent power rating of the reference non-linear load

The non-linear load shall be applied in accordance with the UPS apparent power as follows.

- For single-phase UPS rated for loads up to and including 33 kVA, the apparent power S of the reference non-linear load shall be equal to that of the UPS.
- For single-phase UPS rated for loads in excess of 33 kVA, the apparent power S of the reference non-linear load shall be 33 kVA and a linear load shall be added to reach the apparent and active power rating of the UPS.
- For three-phase UPS rated for loads up to and including 100 kVA, three identical reference non-linear loads shall be connected, either line-neutral or line-to-line, depending on UPS design, so that their total apparent power S equals that of the UPS.
- For three-phase UPS rated above 100 kVA, the load necessary for a three-phase UPS rated at 100 kVA shall be connected, and balanced linear load shall be added to reach the apparent and active power rating of the UPS.

E.3 Adjustment

The non-linear test load shall be adjusted as follows.

- The reference non-linear load test circuit shall initially be connected to an a.c. input supply at the rated output voltage specified for the UPS unit under test.
- The a.c. input supply impedance shall not cause a distortion of the a.c. input waveform greater than 8 % when supplying this test load (requirement of IEC 61000-2-2).

- c) The resistor R_1 shall be adjusted to obtain the rated output apparent power (S), specified in Clause E.1, for the UPS under test. For step-load testing, resistor R_1 shall be adjusted to obtain in proportion to the specified percentage of rated load.
- d) After adjustment of resistor R_1 , the reference non-linear test load shall be applied to the output of the UPS under test without further adjustment.
- e) For test methods involving change of mode of operation and/or step loading, see 6.4.3.3.

E.4 Circuit design

The following keys refer to Figure E.1 and to the design equations in this clause.

U = rated output voltage of UPS, r.m.s.;

f = UPS output frequency in Hz;

U_c = rectified voltage;

S = apparent power across a reference non-linear load - power factor 0,7, i.e. 70 % of the apparent power S will be dissipated as active power in the two resistors R_1 and R_s ;

R_1 = load resistor - set to dissipate an active power equal to 66 % of the total apparent power S ;

R_s = series line resistor - set to dissipate an active power equal to 4 % of the total apparent power S (simulating a 4 % voltage drop in the power lines – see IEC 60364-5-52).

From peak voltage, distortion of line voltage, voltage drop in line cables and ripple voltage of rectified voltage the average of the rectified voltage U_c will be empirically:

$$U_c = \sqrt{2} \times 0,92 \times 0,96 \times 0,975 \times U = 1,22 \times U$$

and the values of resistors R_s , R_1 and capacitor C in farads will be calculated by the following:

$$R_s = 0,04 \times U^2 / S;$$

$$R_1 = U_c^2 / (0,66 \times S);$$

$$C = 7,5 / (f \times R_1).$$

For dual frequency 50 Hz or 60 Hz, 50 Hz shall be used in the calculation. The capacitance value used shall be not less than the calculated value.

NOTE 1 The voltage drop in the diode bridge is neglected.

NOTE 2 Tolerances on calculated component values:

$$R_s = \pm 10 \%;$$

$$R_1 = \text{to be adjusted during test to obtain rated output apparent power};$$

$$C = 0 \% \text{ to } +25 \%.$$

NOTE 3 A ripple voltage of 5 % peak-to-peak of the capacitor voltage U_c corresponds to a time constant of $R_1 \times C = 7,5/f$.

Annex F
(informative)

Information on backfeed protection

Backfeed protection is a requirement verified during safety compliance testing in UPS safety standard IEC 62040-1:2008 Annex I – Backfeed protection test.

First edition of this UPS test and performance standard (IEC 62040-3:1999 – withdrawn) contained an annex (F) that prescribed backfeed protection tests, now excluded to avoid duplicity and any conflict with the UPS safety standard.

*only for research purposes
not for sale
copyright www.psqca.com.pk*

Annex G (normative)

Input mains failure – Test method

G.1 General

The characteristics of the UPS when the mains fail shall be tested using the circuit of Figure G.1.

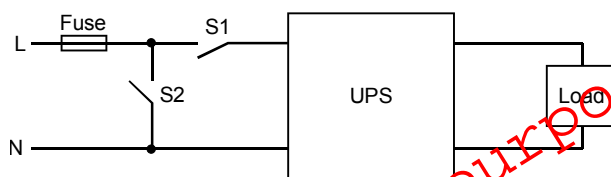

Key

L mains phase(s)

N mains neutral (or phase where no neutral is used)

S1 switch or contactor capable of carrying and opening the UPS rated input current

S2 switch or contactor capable of carrying the mains fault current while the fuse opens

Fuse rated to support the UPS at light load

Figure G.1 – Connection of test circuit

G.2 Test G.1 – High impedance mains failure

Normal mode of operation, light load:

- S1 = closed;
- S2 = open;
- Open S1 to simulate the mains failure.

G.3 Test G.2 – Low impedance mains failure

Normal mode of operation, light load:

- S1 = closed;
- S2 = open;
- Close S2 to simulate the mains failure (fuse blown).

The fuse rating shall comply with the UPS input current. The S2 rating shall be according to the fuse rating.

For use on three-phase supplies, the switch poles of each switch shall open/close simultaneously.

Annex H (informative)

Dynamic output performance – Measurement techniques

H.1 Assessment method

The dynamic output performance of a UPS is specified in 5.3.4 CCC. It is tested against the limits of curves 1, 2 and 3 of Figure 2, 3 and 4 and interpreted as a single event commencing at the instant of the relevant transient condition and lasting until the output voltage returns to steady-state conditions.

The measurement technique should provide test results that permit assessment against both:

- a) any loss or gain in r.m.s. value when compared to the steady-state r.m.s. value;
- b) any instantaneous voltage variation with a duration of 3 ms or less when compared to the steady-state peak value.

The r.m.s. value should be derived by use of a sliding $\frac{1}{2}$ -cycle r.m.s. technique with update every $\frac{1}{2}$ cycle. This is necessary for correct interpretation of asymmetric a.c. voltage waveforms presenting a d.c. offset.

Instruments with capability of performing the required r.m.s. and instantaneous measurements may be procured. Alternatively, a true r.m.s. voltmeter with suitable minimum r.m.s. and maximum r.m.s. functions may be used in conjunction with a storage oscilloscope that can capture transient voltage. In this case, the minimum r.m.s., maximum r.m.s. and instantaneous measurements should be validated through analysis of the oscilloscope waveform captured. See Clause H.2 for details.

NOTE 1 For details about r.m.s. voltage measurement, see IEC/TR 61000-2-8.

NOTE 2 The condition of instantaneous values being measured for variations with duration of 3 ms or less is consistent with industry practice including application notes from the Information Technology Industry Council (ITI) – for more details, see <http://www.itic.org>.

NOTE 3 Linear loads are generally tolerant of single transient deviations not exceeding 100 % of nominal peak voltage for less than 1 ms. Linear loads, often containing magnetic components, are however generally sensitive, on a half-cycle by half-cycle basis, to loss or gain in volt-time area. The loss or gain in r.m.s. value specified above is deemed an adequate technique to measure the latter.

NOTE 4 Non-linear loads of the type represented by the reference non-linear load of Annex E are generally tolerant of loss or gain in the volt-time area during at least one complete half-cycle. The capacitor of the reference non-linear load draws current only when the UPS voltage exceeds the load capacitor voltage and as such is affected only if the UPS peak voltage decreases substantially for a length of time. Dynamic performance considerations for this type of load is generally limited to ensuring the maintenance of the load capacitor voltage within stated limits during transient testing.

NOTE 5 The following transients should not be considered when determining UPS dynamic output performance:

- transients originating external to the UPS on the a.c. input supply and coupled through to the UPS output. These are covered under the immunity requirements of IEC 62040-2;
- steady state repetitive subcycle transients e.g. notches. These are covered under the harmonic voltage requirements in 5.3.4 BB.

H.2 Graphical validating method for instantaneous value

Graphical evaluation of instantaneous voltage variation is used to validate the alternative true r.m.s. voltmeter and storage oscilloscope method described in Clause H.1.

The evaluation consists of transporting the real-time voltage variation from, what would be, the undisturbed voltage to the applicable curve 1, 2 or 3 of Figure 2, 3 and 4. Validation is achieved when the (transported) voltage variation fits within the applicable curve. Figure H.1 exemplifies an instantaneous voltage variation that complies with the requirements of curve 1.

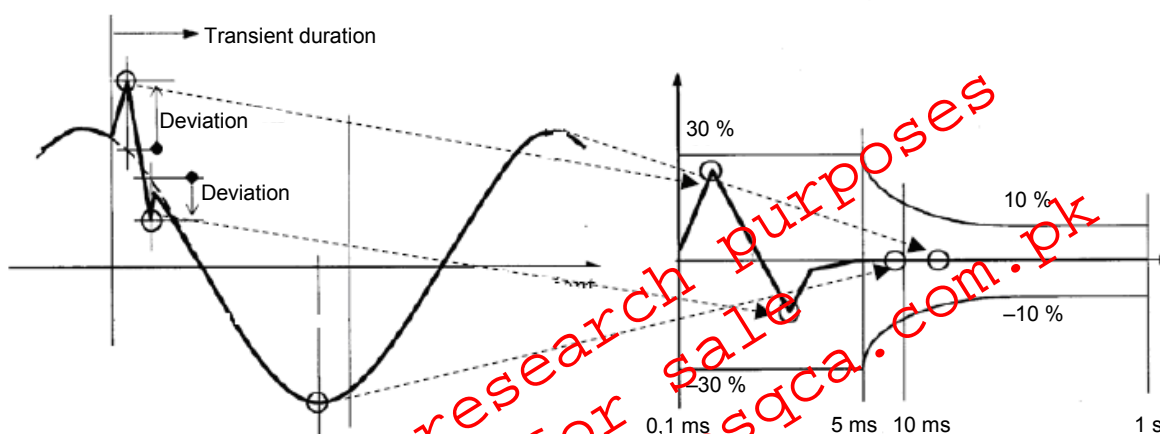

Figure H.1 – Example: instantaneous voltage variation in compliance with curve 1 of Figure 2

NOTE 1 The lowest time indicated on the applicable curve defines what portion of the voltage variation that may be ignored. In Figure H.1, the voltage variation between zero and 0,1 ms is ignored.

NOTE 2 The deviation percentage is calculated in relation to the peak voltage of the previously undisturbed voltage, assumed within requirements.

Annex I (informative)

UPS Efficiency values

I.1 General

Notwithstanding the inherent benefits of supplying energy to a load through a UPS, such procedure results in localised energy losses that are higher than those arising if the same load were supplied directly from the low voltage network. UPS energy losses may however be substantially off-set by taking into account that a UPS, depending on its construction, may condition, isolate and filter adverse load currents that would otherwise impose additional demands on the low-voltage network, and thus require oversizing of the latter. Examples of such demands include the effect of reactive and/or harmonic current circulation due to non-linear and low power factor loads. As a result, a UPS complying with the efficiency limits in this annex is likely to minimise the global effect in respect to energy losses.

I.2 Equipment covered

This annex covers UPS delivering uninterruptible power equal to and in excess of 0,3 kVA when classified in accordance with their normal mode of operation.

I.3 Minimum normal mode UPS efficiency

The normal mode of operation of a UPS defines the UPS classification against which it should be tested for compliance with UPS efficiency.

Tables from I.1 to I.6 provide the minimum UPS efficiency limits (see 5.3.4 for details about performance classifications VFI-S..., VFI, VI, VFD).

NOTE 1 A UPS that permits alternative modes of normal operation should be tested against all applicable UPS efficiency tables corresponding to such modes of normal operation.

NOTE 2 National requirements may differ from the efficiency limits of this annex. This annex is aligned with the Uninterruptible Power System Code of Conduct V1-0a dated 22 January 2008 (only for UPS rated from 10kVA and above) and published by of the Institute for the Environment and Sustainability Renewable Energies Unit of the European Commission Directorate General Joint Research Centre.

NOTE 3 For a.c. systems having a nominal voltage between 100 V and 1 000 V inclusive, the minimum efficiency required by a UPS designed to operate at a voltage other than those in Tables I.1 to I.6 may be obtained by linear inter- and/or extrapolation. Where input and output voltages differ, for the purpose of Tables I.1 to I.6, the lowest voltage prevails.

NOTE 4 Inter- and extrapolation is permitted where exact 25 %, 50 %, 75 % and 100 % test loads are not available, provided that the actual load is within ± 5 % (based on 100 %).

**Table I.1 – Efficiency for UPS rated from 0,3 kVA to less than 10,0 kVA
with classification “VFI – S...”**

Voltage V	Load %	UPS rating kVA				
		≥0,3 to <0,8	≥0,8 to <1,5	≥1,5 to <3,5	≥3,5 to <5,0	≥5,0 to <10,0
120/208	25	66,5 %	66,5 %	72,7 %	77,7 %	78,3 %
	50	67,8 %	75,2 %	78,9 %	80,2 %	81,4 %
	75	72,7 %	77,7 %	78,9 %	82,6 %	83,9 %
	100	75,2 %	77,7 %	80,2 %	82,6 %	83,9 %
230/400	25	73,0 %	73,0 %	78,0 %	82,0 %	82,5 %
	50	74,0 %	80,0 %	83,0 %	84,0 %	85,0 %
	75	78,0 %	82,0 %	83,0 %	86,0 %	87,0 %
	100	80,0 %	82,0 %	84,0 %	86,0 %	87,0 %
277/480	25	75,7 %	75,7 %	80,2 %	83,8 %	84,3 %
	50	76,6 %	82,0 %	84,7 %	85,6 %	86,5 %
	75	80,2 %	83,8 %	84,7 %	87,4 %	88,3 %
	100	82,0 %	83,8 %	85,6 %	87,4 %	88,3 %

**Table I.2 – Efficiency for UPS rated from 0,3 kVA to less than 10,0 kVA
with classification VI and VFI, except “VFI – S...”**

Voltage V	Load %	UPS rating kVA				
		≥0,3 to <0,8	≥0,8 to <1,5	≥1,5 to <3,5	≥3,5 to <5,0	≥5,0 to <10,0
120/208	25	76,2 %	82,1 %	82,1 %	82,1 %	82,7 %
	50	84,5 %	85,7 %	86,9 %	89,3 %	89,9 %
	75	85,1 %	86,3 %	88,0 %	90,5 %	91,1 %
	100	85,7 %	86,9 %	88,1 %	90,5 %	91,1 %
230/400	25	80,0 %	85,0 %	85,0 %	85,0 %	85,5 %
	50	87,0 %	88,0 %	89,0 %	91,0 %	91,5 %
	75	87,5 %	88,5 %	89,9 %	92,0 %	92,5 %
	100	88,0 %	89,0 %	90,0 %	92,0 %	92,5 %
277/480	25	81,6 %	86,2 %	86,2 %	86,2 %	86,7 %
	50	88,0 %	89,0 %	89,9 %	91,7 %	92,2 %
	75	88,5 %	89,4 %	90,7 %	92,6 %	93,1 %
	100	89,0 %	89,9 %	90,8 %	92,6 %	93,1 %

Table I.3 – Efficiency for UPS rated from 0,3 kVA to less than 10,0 kVA with classification VFD

Voltage V	Load %	UPS rating kVA				
		≥0,3 to <0,8	≥0,8 to <1,5	≥1,5 to <3,5	≥3,5 to <5,0	≥5,0 to <10,0
120/208	25	84,7 %	85,8 %	86,6 %	87,9 %	89,0 %
	50	85,8 %	86,8 %	87,7 %	91,2 %	92,3 %
	75	86,8 %	87,9 %	88,8 %	92,3 %	93,4 %
	100	87,9 %	89,0 %	89,9 %	92,3 %	93,4 %
230/400	25	86,0 %	87,0 %	87,8 %	89,0 %	90,0 %
	50	87,0 %	88,0 %	88,8 %	92,0 %	93,0 %
	75	88,0 %	89,0 %	89,8 %	93,0 %	94,0 %
	100	89,0 %	90,0 %	90,8 %	93,0 %	94,0 %
277/480	25	86,6 %	87,5 %	88,2 %	89,4 %	90,4 %
	50	87,5 %	88,5 %	89,2 %	92,3 %	93,3 %
	75	88,5 %	89,4 %	90,2 %	93,3 %	94,2 %
	100	89,4 %	90,4 %	91,2 %	93,3 %	94,2 %

Table I.4 – Efficiency for UPS rated from 10,0 kVA (inclusive) and above with classification “VFI – S...”

Voltage V	Load %	UPS rating kVA			
		≥ 10 to < 20	≥ 20 to < 40	≥ 40 to < 200	≥ 200
120/208	25	78,9 %	80,2 %	83,3 %	86,4 %
	50	86,4 %	87,0 %	88,2 %	90,1 %
	75	88,2 %	88,8 %	90,1 %	91,3 %
	100	88,8 %	89,5 %	90,1 %	91,3 %
230/400	25	83,0 %	84,0 %	86,5 %	89,0 %
	50	89,0 %	89,5 %	90,5 %	92,0 %
	75	90,5 %	91,0 %	92,0 %	93,0 %
	100	91,0 %	91,5 %	92,0 %	93,0 %
277/480	25	84,7 %	85,6 %	87,9 %	90,1 %
	50	90,1 %	90,6 %	91,5 %	92,8 %
	75	91,5 %	91,9 %	92,8 %	93,7 %
	100	91,9 %	92,4 %	92,8 %	93,7 %

Table I.5 – Efficiency for UPS rated from 10,0 kVA (inclusive) and above with classification VI and VFI, except "VFI – S..."

Voltage V	Load %	UPS rating kVA			
		≥ 10 to < 20	≥ 20 to < 40	≥ 40 to < 200	≥ 200
120/208	25	85,7 %	86,3 %	86,9 %	89,9 %
	50	90,5 %	91,1 %	91,7 %	93,4 %
	75	91,1 %	91,7 %	92,3 %	93,4 %
	100	91,1 %	91,7 %	92,3 %	93,4 %
230/400	25	88,0 %	88,5 %	89,0 %	91,5 %
	50	92,0 %	92,5 %	93,0 %	94,5 %
	75	92,5 %	93,0 %	93,5 %	94,5 %
	100	92,5 %	93,0 %	93,5 %	94,5 %
277/480	25	89,0 %	89,4 %	89,9 %	92,2 %
	50	92,6 %	93,1 %	93,6 %	94,9 %
	75	93,1 %	93,6 %	94,0 %	94,9 %
	100	93,1 %	93,6 %	94,0 %	94,9 %

Table I.6 – Efficiency for UPS rated from 10,0 kVA (inclusive) and above with classification VFD

Voltage V	Load %	UPS rating kVA			
		≥ 10 to < 20	≥ 20 to < 40	≥ 40 to < 200	≥ 200
120/208	25	92,3 %	92,9 %	93,4 %	94,5 %
	50	94,5 %	95,1 %	95,6 %	96,7 %
	75	95,3 %	95,9 %	96,4 %	97,5 %
	100	95,6 %	96,2 %	96,7 %	97,8 %
230/400	25	93,0 %	93,5 %	94,0 %	95,0 %
	50	95,0 %	95,5 %	96,0 %	97,0 %
	75	95,7 %	96,3 %	96,7 %	97,7 %
	100	96,0 %	96,5 %	97,0 %	98,0 %
277/480	25	93,3 %	93,8 %	94,2 %	95,2 %
	50	95,2 %	95,7 %	96,2 %	97,1 %
	75	95,9 %	96,4 %	96,8 %	97,8 %
	100	96,2 %	96,6 %	97,1 %	98,1 %

I.4 UPS efficiency allowances

Certain features, when added to the basic UPS configuration, permit allowances to be deducted from the UPS efficiency specified in Tables I.1 to I.6. The allowance shall only apply when the UPS, as a result of providing the corresponding feature, facilitates conditions that could otherwise not be supported. Allowances are limited to one isolation transformer and one filter per a.c. power path. Examples of allowance calculation are provided in Clause I.5.

Table I.7 – UPS efficiency allowances for input or output isolation transformer

UPS load (% of rated) ⁵	UPS rating kVA									
	≥ 0,3 to < 10		≥ 10 to < 40		≥ 40 to < 200		≥ 200 to < 500		≥ 500	
	Duty	Stand-by	Duty	Stand-by	Duty	Stand-by	Duty	Stand-by	Duty	Stand-by
25	6,0 %	5,5 %	6,0 %	5,5 %	4,0 %	3,5 %	2,8 %	2,3 %	1,9 %	1,4 %
50	3,9 %	2,7 %	3,9 %	2,7 %	2,9 %	1,7 %	2,2 %	1,1 %	1,5 %	0,7 %
75	3,5 %	1,8 %	3,5 %	1,8 %	2,9 %	1,2 %	2,4 %	0,8 %	1,7 %	0,5 %
100	3,6 %	1,4 %	3,6 %	1,4 %	3,2 %	0,9 %	2,7 %	0,6 %	2,0 %	0,4 %

Table I.8 – UPS efficiency allowances for input harmonic current filtering

UPS load (% of rated) ⁵	UPS rating kVA									
	≥ 0,3 to < 10		≥ 10 to < 20		≥ 20 to < 40		≥ 40 to < 200		≥ 200	
	Duty	Stand-by	Duty	Stand-by	Duty	Stand-by	Duty	Stand-by	Duty	Stand-by
25	6,1 %	5,5 %	6,1 %	5,5 %	5,7 %	5,1 %	5,0 %	4,1 %	4,0 %	3,2 %
50	3,8 %	2,8 %	3,8 %	2,8 %	3,6 %	2,6 %	3,4 %	2,0 %	2,9 %	1,6 %
75	3,2 %	1,8 %	3,2 %	1,8 %	3,0 %	1,7 %	2,9 %	1,4 %	2,5 %	1,1 %
100	3,0 %	1,4 %	3,0 %	1,4 %	2,9 %	1,3 %	2,9 %	1,0 %	2,5 %	0,8 %

NOTE 1 The allowances in Table I.7 apply when the additional input or output isolation transformer is necessary to ensure separation between two input sources or between input and output sources.

NOTE 2 The allowances in Table I.8 apply when the additional filter is necessary to ensure compatibility with a.c. input sources requiring harmonic current distortion lower than the applicable limits specified in IEC 61000-3-2, IEC/TS 61000-3-4 and IEC 61000-3-12.

NOTE 3 Harmonic filtering can be achieved through passive components, or active components or both including active front-end PWM converters that also provide power factor correction.

NOTE 4 Pro-rata deduction applies when the additional device is rated for partial UPS load only.

NOTE 5 "Duty" allowance applies when, in normal mode, the loss resulting from the additional feature is a function of the UPS load. Otherwise, "stand-by" allowance applies.

I.5 Examples of allowance calculation

The allowance assessment consists of verifying whether the added feature supports a condition that would otherwise not be supported.

Figure I.1 illustrates a VFI S UPS complying with this standard and to which has been added an input filter and an isolation transformer in the bypass line of supply.

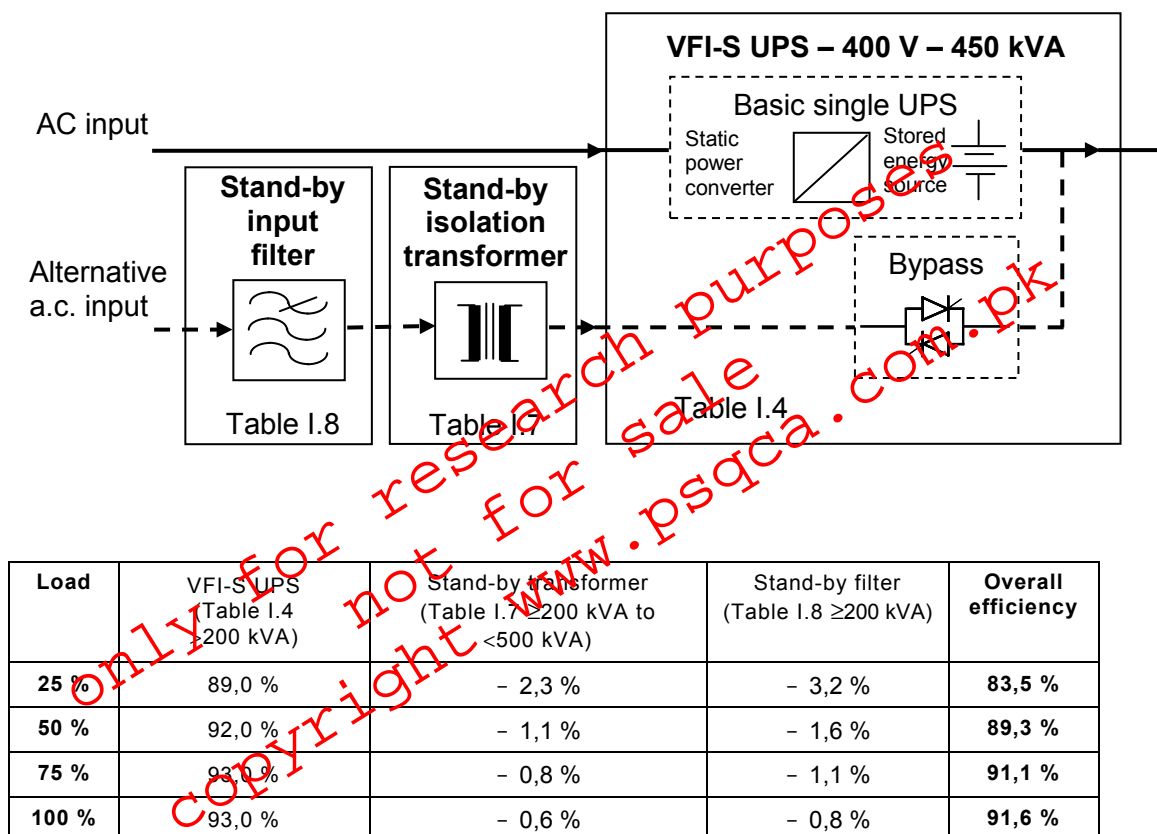

Figure I.1 – Example of VFI-S stand-by allowance

The VFI-S UPS efficiencies of Table I.4 apply.

The “stand-by” allowances of Table I.7 apply because

- the isolation transformer permits the UPS to be supplied from two separately derived and independently grounded a.c. input sources;
- in normal VFI mode, the (bypass) transformer losses are not a function of the load.

The “stand-by” allowances of Table I.8 apply because

- the input filter permits bypass operation with **reference non-linear load**, if designed to attenuate current harmonics to values that comply with applicable limits of IEC 61000-3-2, IEC/TS 61000-3-4 and IEC 61000-3-12;
- in normal VFI mode, the (bypass) filter losses are not a function of the load.

Figure I.2 illustrates a VFI S UPS complying with this standard and to which has been added two duty isolation transformers in the normal mode line of supply.

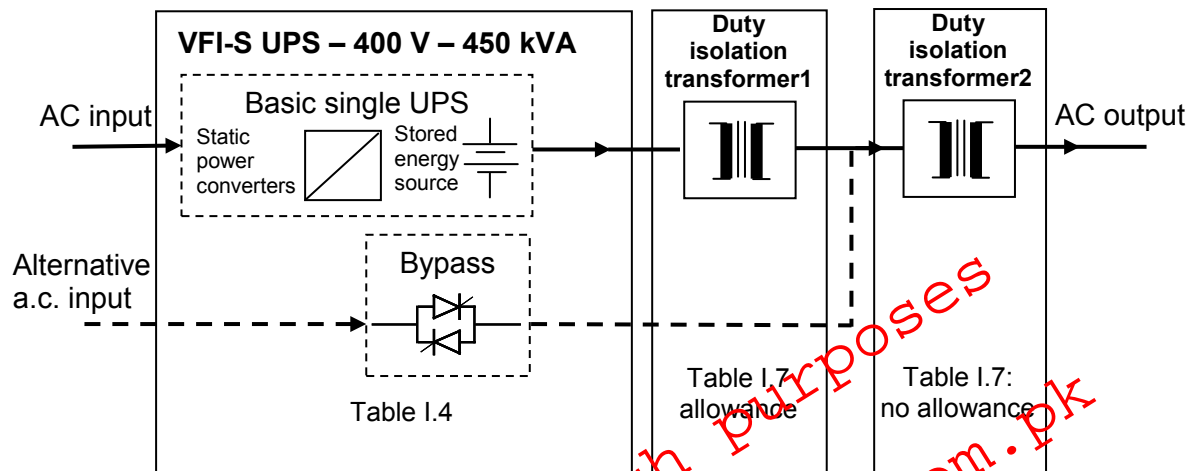

Load	VFI-S UPS (Table I.4 >200 kVA)	Duty transformer 1 (Table I.7 >200 kVA to ≤500 kVA)	Duty transformer 2	Overall Efficiency
25 %	89,0 %	- 2,8 %	- 0,0 %	86,2 %
50 %	92,0 %	- 2,2 %	- 0,0 %	89,8 %
75 %	93,0 %	- 2,4 %	- 0,0 %	90,6 %
100 %	93,0 %	- 2,7 %	- 0,0 %	90,3 %

Figure I.2 – Example of VFI-S duty allowance

The VFI-S UPS efficiencies of Table I.4 apply.

The “duty” allowances of Table I.7 apply for isolation transformer 1 because

- the isolation transformer permits the UPS to be supplied from two separately derived and independently grounded a.c. input sources;
- in normal VFI mode the transformer losses are a function of the load.

The “duty” allowances of Table I.7 do not apply for isolation transformer 2 because

- transformer 1 and transformer 2 are both in the same line of supply;
- duty allowance has already been granted to transformer 1.

Figure I.3 illustrates a VFI S UPS complying with this standard and to which has been added:

- one duty isolation transformer in the normal mode line of supply;
- one stand-by isolation transformer in the bypass line of supply.

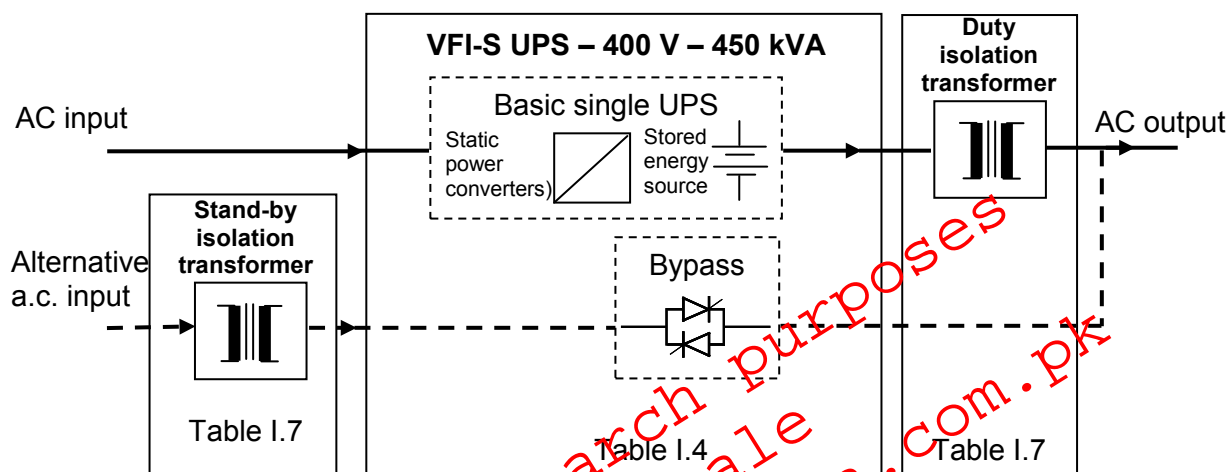

Load	VFI-S UPS (Table I.4 >200 kVA)	Stand-by transformer (Table I.7 ≥200 kVA to <500 kVA)	Duty transformer (Table I.7 ≥200 to <500 kVA)	Overall efficiency
25 %	89,0 %	2,3 %	- 2,8 %	83,9 %
50 %	92,0 %	- 1,1 %	- 2,2 %	88,7 %
75 %	93,0 %	- 0,8 %	- 2,4 %	89,8 %
100 %	93,0 %	- 0,6 %	- 2,7 %	89,7 %

Figure I.3 – Example of VFI-S stand-by and duty allowance

The VFI-S UPS efficiencies of Table I.4 apply.

The “stand-by” allowances of Table I.7 apply to the stand-by isolation transformer because

- the isolation transformer permits the UPS to be supplied from two separately derived and independently grounded a.c. input sources;
- in normal VFI mode, the (bypass) transformer losses are not a function of the load.

The “duty” allowances of Table I.7 apply for the duty isolation transformer because

- the isolation transformer permits the output of the UPS to be independently grounded;
- in normal VFI mode, the transformer losses are a function of the load.

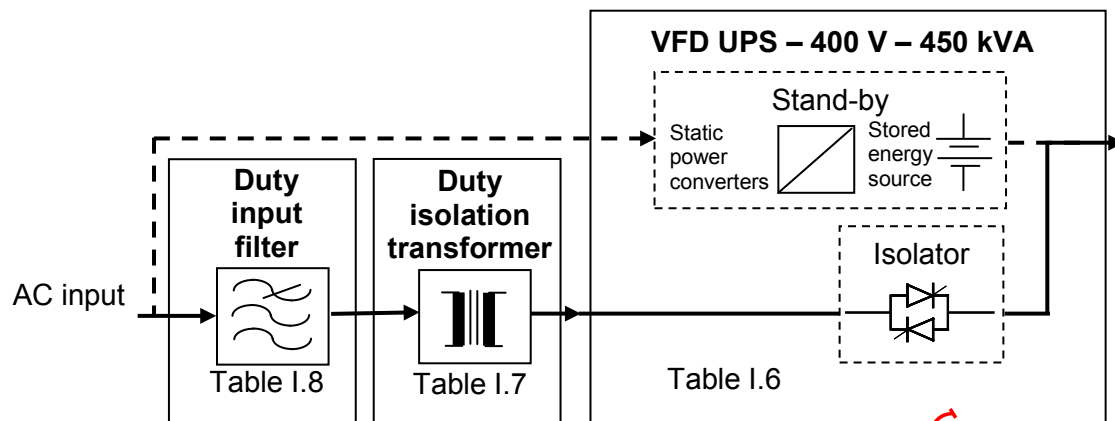

Load	VFD UPS (Table I.6 >200 kVA)	Duty transformer (Table I.7 ≥200 kVA to <500 kVA)	Duty filter (Table I.8 ≥200 kVA)	Overall efficiency
25 %	95,0 %	- 2,8 %	- 4,0 %	88,2 %
50 %	97,0 %	- 2,2 %	- 2,9 %	91,9 %
75 %	97,7 %	- 2,4 %	- 2,5 %	92,8 %
100 %	98,0 %	- 2,7 %	- 2,5 %	92,8 %

Figure 1.4 – Example of VFD duty allowance calculation

The VFD UPS efficiencies of Table I.6 apply.

The “duty” allowances of Table I.7 apply because

- the Isolation transformer permits the UPS to be supplied from two separately derived and independently grounded a.c. input sources;
- in normal VFD mode, the (bypass) transformer losses are a function of the load.

The “duty” allowances of Table I.8 apply because

- the input filter permits normal VFD mode operation with **reference non-linear load** if designed to attenuate current harmonics to values that comply with applicable limits of IEC 61000-3-2, IEC/TS 61000-3-4 and IEC 61000-3-12;
- in normal VFD mode, the filter losses are a function of the load.

Annex J (normative)

UPS efficiency – Methods of measurement

J.1 General

This annex prescribes conditions and methods to be followed when determining **UPS efficiency** during type tests specified in 6.4.1.6.

J.2 Measurement conditions

J.2.1 Environmental conditions

The ambient temperature shall be between 20 °C to 30 °C and remaining environmental conditions shall be within the limits specified in 4.2.

J.2.2 Operational and electrical conditions

It is recognized that optimum efficiency for some UPSs can be achieved with load conditions that do not present power factor (PF)=1. However, for the purpose of this annex, the efficiency measurements shall be performed with a **reference test load** of PF=1 capable of being adjusted so that the UPS delivers 25 %, 50 %, 75 % and 100 % of the active power (W) for which it is rated. The following requirements apply for each measurement:

- a) the UPS shall operate in **normal mode**;
- b) transfer of energy to and from the **energy storage system** shall be prevented during the test. The **energy storage system** may be disconnected during the test to prevent such transfer of energy;
- c) the UPS and the load shall have been operated for a sufficient length of time to reach steady state conditions. The length of time determined during temperature rise type tests plus 25 % is considered sufficient. Alternatively, trend variation of less than 2 °C temperature variation over not less than three consecutive readings with no less than 10 min interval may be considered steady-state for the purpose of this annex;
- d) each load condition shall be within the range of 95 % to 105 % of the intended load and the power factor shall be 0,99 or greater;
- e) all UPS sub-systems intended to be operational in **normal mode** shall be activated;
- f) the a.c. input to the UPS shall be at 97 % to 103 % of the rated voltage and 99 % to 101 % of the rated frequency and otherwise within the tolerances specified in IEC 61000-2-2;

NOTE 1 The test with resistive load is considered to be the most reliable in terms of repeatability and constitutes a solid base for the evaluation of efficiency improvements at all load levels.

NOTE 2 For tolerances, refer to 7.8 of IEC 60146-1-1.

J.2.3 Instrumentation

The combination of instruments and transducers used for the measurement of UPS efficiency shall:

- provide true r.m.s. measurements of the active input and output power, with an uncertainty at full rated load of less than or equal to 0,5 % at the 95 % confidence level notwithstanding that voltage and current waveforms can include harmonic components;

- measure input and output values simultaneously.

NOTE 1 The confidence level of an instrument's uncertainty should be understood as the probability of measurements presented by such instrument being accurate within the uncertainty limits. A normal distribution of data with coverage factor 1,960 represents a 95 % confidence level which is a generally accepted level. For further information, refer to ISO/IEC Guide 98-3.

NOTE 2 Simultaneous input and output measurements are generally provided through separate input and output instruments. Nevertheless, one single multi-channel instrument providing fast serial sampling ("multiplexed sampling") is also deemed to provide simultaneous measurements.

J.3 Measurement method

J.3.1 Standard method

Under the conditions specified in J.2.1 and J.2.2, using the instrumentation described in J.2.3, the measurement of the UPS efficiency shall be carried out as follows:

- 100 % **reference test load** shall be applied to the output of the UPS and a suitable stabilization time be allowed to reach the steady-state conditions as specified above;
- the active input and output power (W) shall be measured simultaneously in three successive readings taken no more than 15 min apart. The **UPS efficiency** shall be calculated for each reading;

NOTE 1 Where the **reference test load** is implemented by means of returning the output power to the UPS input, the total input power equals the UPS output power plus that supplied by the a.c. input source.

NOTE 2 Where a UPS is connected to more than one input source, the active input power to be considered is the sum of all inputs.

NOTE 3 Where a UPS supplies more than one output, the active output power to be considered is the sum of all outputs.

- the arithmetic mean of the 3 UPS efficiencies calculated in b) shall then be obtained. The result is considered to be the value of the efficiency measure;
- steps a) b) and c) shall be repeated but for 75 %, 50 %, and 25 % reference load conditions.

J.3.2 Alternative method

It is acknowledged that instruments and transducers meeting the requirements of J.2.3 may not be commercially available. Therefore, the use of instruments and transducers providing measurement uncertainty greater than allowed by J.2.3 is permitted provided that the standard method is varied as follows.

In J.3.1, replace step c) by:

- the input and output measuring instruments and transducers if any, shall be exchanged and step b) shall be repeated. The arithmetic mean of all 6 resulting UPS efficiencies is considered to be the value of the efficiency measure.

J.4 Test report

A recommended format for the test report is provided in Clause D.6. Should the UPS technical sheet in Clause D.6 be used, the sheet shall be completed for each performance classification declared by the manufacturer.

The following information shall be recorded in the test report:

a) equipment details

- brand, model, type, and serial number;
- product description, as appropriate;
- rated voltage and frequency;
- rated output active and apparent power;
- details of manufacturer marked on the product (if any);
- in the case of products with multiple functions or with options to include additional modules or attachments, the configuration of the appliance as tested shall be noted in the report.

NOTE The details above can be found and should be consistent with those of Clause D.6 Technical data sheet - Manufacturer's declaration.

b) test parameters

- ambient temperature (°C);
- input and output test voltage (V) and frequency (Hz);
- total harmonic input voltage distortion;
- information and documentation on the instrumentation, set-up and circuits used for electrical testing.

c) measured data

- efficiency in % rounded to the first decimal place at the given **rated** load fraction;
- measurement method used: either J.3.1 or J.3.2 of IEC 62040-3;
- any notes regarding the operation of the equipment.

d) test and laboratory details

- test report number reference;
- date of test;
- name and signature of authorized test person(s).

Annex K (informative)

UPS functional availability

K.1 General

For the purpose of this part 3 of IEC 62040, UPS functional availability contains certain reliability concepts detailed in IEC 61508.

While functional safety as defined in IEC 61508 is mainly concerned with systems whose failure rate and reliability could reduce the level of safety of persons, or property, or both, the concept of functional availability is extrapolated to evaluate the likelihood of UPS availability to support the load. For clarity, the IEC term “functional safety” as used in IEC 61508 has been replaced with the term “functional availability” and “safety integrity level” has been replaced by “reliability integrity level”.

For the purpose of this annex, the failure to be avoided is a power failure to the critical load connected to the UPS output. A power failure is deemed to have occurred when the UPS output voltage (see “a.c. output” in the Annex A figures) is outside the range of the applicable dynamic output performance classification 1, 2 or 3 tolerated by the load. Functional availability does not use the concept of being “fail safe”.

The following output power loss conditions are not considered to be failures:

- a) the loss of power to the load at the end of specified stored energy run time;
- b) the failure of a single a.c. output on a UPS with redundant a.c. outputs.

K.2 Downstream distribution failures in the a.c. output of UPS

Failures in the electrical distribution downstream of the a.c. output also produce power failure. Therefore particular care should be taken in designing, installing and maintaining the electrical distribution system.

K.3 Functional reliability integrity levels

Reliability integrity levels (RILs) determine the lower limit target level of integrity for the functions to be implemented by the UPS and adopt a risk-based approach for the determination of requirements. Numerical target failure measures are set for a UPS linked to a particular RIL as shown in Table K.1.

Table K.1 – Reliability integrity levels for UPS

Reliability integrity level	Probability of output power failure per hour in high demand or continuous mode of operation
4	$\geq 10^{-9}$ to $< 10^{-8}$
3	$\geq 10^{-8}$ to $< 10^{-7}$
2	$\geq 10^{-7}$ to $< 10^{-6}$
1	$\geq 10^{-6}$ to $< 10^{-5}$

K.4 Functional availability calculations

The functional availability of a UPS indicates the expected percentage of time at which, during its useful life, the UPS complies with its objective of avoiding a power failure to the critical load. For the purpose of this annex, the UPS is in a high demand or continuous mode of operation.

The functional availability (A) is expressed by the ratio of the MTBF to the sum of the MTBF (= 1 / failure rate) and MTTR:

$$A = \text{MTBF} / (\text{MTBF} + \text{MTTR})$$

where

A is the availability of a UPS;

MTBF is the mean time between failures, assumed to be constant;

MTTR is the mean time to repair, assumed to be constant.

A UPS with RIL1 presents $\geq 10^{-6}$ to $< 10^{-5}$ power failures per hour to the critical load, meaning that its MTBF is between $1/10^{-5}$ and $1/10^{-6}$ hours i.e. between 100 000 and 1 000 000 hours. The availability of such a UPS, assuming a MTTR of 6 h, is between 99,9940 % (100 000/100 006) and 99,9994 %, (1 000 000/1 000 006) generally known in the industry as “4 to 5 nines of availability.”

Constant MTBF and MTTR conditions characterise a UPS during its useful life. The availability arising is known as “steady-state” or “asymptotic” availability.

MTBF affects the reliability [$r(t) = e^{-t/\text{MTBF}}$] that represents the estimated chance of avoiding power failure to the critical load after at least “t” hours of operation.

MTTR affects the maintainability [$m(t) = 1 - e^{-t/\text{MTTR}}$] that represents the estimated chance of having restored power to the critical load after no more than “t” hours of repair. In Figure K.1 and Figure K.2, times $t = 0$, $t = \text{MTTR}$ and $t = \text{MTBF}$ define important characteristics of reliability and maintainability:

In Figure K.1, when $t = 0$, $r(0) = e^{-0/\text{MTBF}} = 1 = 100\%$, meaning that the UPS is working. When $t = \text{MTBF}$, $r(\text{MTBF}) = e^{-\text{MTBF}/\text{MTBF}} = e^{-1} = 0,37 = 37\%$, meaning that there is 37 % chance of avoiding power failure to the critical load if the UPS is left operating for the next “MTBF” hours.

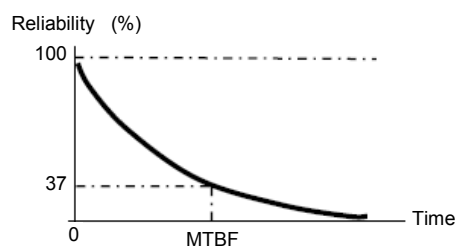

Figure K.1 – Reliability % over time

In Figure K.2, when $t = 0$, $m(0) = 1 - e^{-0/MTTR} = 0 = 0\%$, meaning that the UPS is not repaired. When $t = MTTR$, $m(MTTR) = 1 - e^{-MTTR/MTTR} = 1 - e^{-1} = 0,63 = 63\%$, meaning that there is 63 % chance that the UPS will again supply the load after “MTTR” hours of repair.

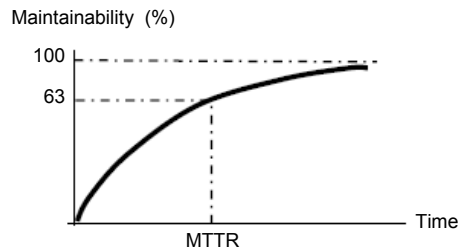

Figure K.2 – Maintainability % over time

K.5 Industry practice

A UPS built and tested to satisfy the requirements of a particular reliability/integrity level will confidently offer a specified availability of power to the critical load when appropriate service (maintenance) conditions are adhered to. These conditions include monitoring of the UPS, the availability of spare parts and of personnel to perform maintenance as well as training and become critical as the required MTTR decreases.

Concepts like “high nines availability” and “tiers of availability” represent industry practice that has been adopted in data centres even if not being an international standard. They should not to be interpreted as the functional safety defined in IEC 61508.

As an example of industry practice, the Uptime Institute (<http://uptimeinstitute.org>), promote a 4-tier availability classification consisting of

- Tier I, Basic: single path, no redundant components;
- Tier II, Redundant: single path, no redundant components;
- Tier III, Concurrently maintainable: multiple paths, redundant components;
- Tier IV, Fault tolerant: multiple paths, redundant components.

Bibliography

IEC 60034-22, *Rotating electrical machines – Part 22: AC generators for reciprocating internal combustion (RIC) engine driven generating sets*

IEC 60050-111:1996, *International Electrotechnical Vocabulary – Chapter 111: Physics and chemistry*

IEC 60051-131:2002, *International Electrotechnical Vocabulary – Part 131: Circuit theory*

IEC 60050-151:2001, *International Electrotechnical Vocabulary – Part 151: Electrical and magnetic devices*

IEC 60050-161:1990, *International Electrotechnical Vocabulary – Chapter 161: Electromagnetic compatibility*
Amendment 1 (1997)
Amendment 1 (1998)

IEC 60050-351:2006, *International Electrotechnical Vocabulary – Part 351: Control technology*

IEC 60050-441:1984, *International Electrotechnical Vocabulary – Switchgear, controlgear and fuses*
Amendment 1 (2000)

IEC 60050-442:1998, *International Electrotechnical Vocabulary – Part 442: Electrical accessories*

CEI 60050-482:2004, *International Electrotechnical Vocabulary – Part 482: Primary and secondary cells and batteries*

IEC 60050-551:1998, *International Electrotechnical Vocabulary – Part 551: Power electronics*

IEC 60050-826:2004, *International Electrotechnical Vocabulary – Part 826: Electrical installations*

IEC 60068-1:1988, *Environmental testing – Part 1: General and guidance*

IEC 60068-2 (all parts 2), *Environmental testing – Part 2: Tests*

IEC 60068-3-3:1991, *Environmental testing – Part 3: Guidance – Seismic test methods for equipment*

IEC 60146-1-3:1991, *Semiconductor convertors – General requirements and line commutated convertors – Part 1- 3: Transformers and reactors*

IEC 60664-1:2007, *Insulation coordination for equipment within low-voltage systems – Part 1: Principles, requirements and tests*

IEC/TR 61000-2-8, *Electromagnetic compatibility (EMC) – Part 2-8: Environment – Voltage dips and short interruptions on public electric power supply systems with statistical measurement results*

IEC/TR 61508 (all parts), *Functional safety of electrical/electronic/programmable electronic safety-related systems*

ISO/IEC Guide 98-3:2008, *Uncertainty of measurement – Part 3: Guide to the expression of uncertainty in measurement (GUM:1995)*

ANSI C57.96:1999 – *Guide for Loading Dry Type Distribution and Power Transformers*

only for research purposes
not for sale
copyright www.psqca.com.pk