

**PS: IEC 60268-5/2014**  
**ICS NO: 33.160.50**

## **PAKISTAN STANDARD**

---

### **SOUND SYSTEM EQUIPMENT – PART 5: LOUDSPEAKERS.**



---

(All Rights Reserved)

**PAKISTAN STANDARDS AND QUALITY CONTROL AUTHORITY,**  
STANDARDS DEVELOPMENT CENTRE,  
PSQCA COMPLEX, PLOT NO. ST – 7/A, BLOCK NO. 3,  
SCHEME – 36, GULISTAN-E-JAUHAR,  
KARACHI.

**DRAFT**

**PAKISTAN STANDARD SPECIFICATION**

**FOR**

**SOUND SYSTEM EQUIPMENT - PART 5: LOUDSPEAKERS**

**0. FOREWORD**

- 0.1 This Pakistan Standard was adopted by Standards Development Centre / Pakistan Standards and Quality Control Authority (PSQCA), after the draft prepared by the Technical Committee for “**Recording / Audio, video systems (ESTC - 8)**” had been approved and endorsed by the National Standards Committee for Electronics on 11-11-2014
- 0.2 This standard is an adoption of IEC 60268-5-2007 Sound system equipment – Part 5: Loudspeakers.
- 0.3 This Standard has been prepared and finalized after taking into consideration the views and suggestions put forwarded by the representative section of technologists, manufacturers and utilizing agencies.
- 0.4 This Standard is subject to periodical review in order to keep pace with the changing requirements and latest development in the industry. Any suggestion for improvement will be recorded and placed before the revising committee in due course.
- 0.5 This Standard covers the technical provisions and it does not purport to include all the necessary provisions of a contract.

-----

## CONTENTS

1	Scope.....	5
2	Normative references .....	5
3	Conditions for measurement .....	6
3.1	General conditions .....	6
3.2	Measuring conditions .....	6
4	Test signals .....	7
4.1	General.....	7
4.2	Sinusoidal signal .....	7
4.3	Broadband noise signal .....	7
4.4	Narrow-band noise signal .....	7
4.5	Impulsive signal .....	7
5	Acoustical environment .....	7
5.1	General.....	7
5.2	Free-field conditions.....	8
5.3	Half-space free-field conditions .....	8
5.4	Diffuse sound field conditions .....	8
5.5	Simulated free-field conditions .....	8
5.6	Half-space simulated free-field conditions .....	9
6	Unwanted acoustical and electrical noise .....	9
7	Positioning of loudspeaker and measuring microphone.....	9
7.1	Measuring distance under free-field and half-space free-field conditions .....	9
7.2	Positioning of loudspeaker in diffuse field conditions .....	9
7.3	Positioning of loudspeaker and microphone in simulated free-field conditions .....	10
8	Measuring equipment.....	10
9	Accuracy of the acoustical measurement .....	10
10	Mounting of loudspeakers.....	10
10.1	Mounting and acoustic loading of drive units .....	10
10.2	Mounting and acoustic loading of a loudspeaker system.....	11
11	Standard baffle and measuring enclosures .....	11
11.1	Standard baffle.....	11
11.2	Standard measuring enclosures .....	11
12	Preconditioning .....	12
13	Type description .....	12
13.1	General.....	12
13.2	Loudspeaker drive units .....	12
13.3	Loudspeaker system .....	12
14	Marking of terminals and controls .....	13
14.1	General.....	13
14.2	Positive terminal.....	13
15	Reference plane, reference point and reference axis .....	13
15.1	Reference plane – characteristic to be specified.....	13
15.2	Reference point – characteristic to be specified.....	13
15.3	Reference axis – characteristic to be specified .....	14

16	Impedance and derivative characteristics .....	14
16.1	Rated impedance – characteristic to be specified .....	14
16.2	Impedance curve .....	14
16.3	Total Q-factor ( $Q_t$ ) .....	14
16.4	Equivalent air volume of a loudspeaker drive unit compliance ( $V_{as}$ ) .....	16
17	Input voltage .....	17
17.1	Rated noise voltage .....	17
17.2	Short-term maximum input voltage .....	18
17.3	Long-term maximum input voltage .....	18
17.4	Rated sinusoidal voltage .....	19
18	Input electrical power .....	19
18.1	Rated noise power – characteristic to be specified .....	19
18.2	Short-term maximum power – characteristic to be specified .....	20
18.3	Long-term maximum power – characteristic to be specified .....	20
18.4	Rated sinusoidal power – characteristic to be specified .....	20
19	Frequency characteristics .....	20
19.1	Rated frequency range – characteristic to be specified .....	20
19.2	Resonance frequency .....	20
19.3	Tuning frequency of a bass reflex or passive radiator loudspeaker system – characteristic to be specified .....	20
20	Sound pressure under free-field and half-space free-field conditions .....	21
20.1	Sound pressure in a stated frequency band .....	21
20.2	Sound pressure level in a stated frequency band – characteristic to be specified .....	21
20.3	Characteristic sensitivity in a stated frequency band .....	21
20.4	Characteristic sensitivity level in a stated frequency band – characteristic to be specified .....	22
20.5	Mean sound pressure in a stated frequency band .....	22
20.6	Mean sound pressure level in a stated frequency band – characteristic to be specified .....	22
21	Response under free-field and half-space free-field conditions .....	22
21.1	Frequency response .....	22
21.2	Effective frequency range .....	23
21.3	Transfer function .....	24
22	Output power (acoustic power) .....	25
22.1	Acoustic power in a frequency band .....	25
22.2	Mean acoustic power in a frequency band .....	26
22.3	Efficiency in a frequency band .....	26
22.4	Mean efficiency in a frequency band .....	26
23	Directional characteristics .....	27
23.1	Directional response pattern .....	27
23.2	Radiation angle .....	28
23.3	Directivity index .....	28
23.4	Coverage angle or angles .....	29
24	Amplitude non-linearity .....	30
24.1	Total harmonic distortion .....	30
24.2	Harmonic distortion of the $n^{\text{th}}$ order (where $n = 2$ or $n = 3$ ) .....	31
24.3	Characteristic harmonic distortion .....	33

24.4	Modulation distortion of the $n^{\text{th}}$ order (where $n = 2$ or $n = 3$ ).....	33
24.5	Characteristic modulation distortion of the $n^{\text{th}}$ order (where $n = 2$ or $n = 3$ ) .....	34
24.6	Difference frequency distortion (of the second order only) .....	34
25	Rated ambient conditions .....	35
25.1	Temperature ranges .....	35
25.2	Humidity ranges .....	35
26	Stray magnetic fields .....	35
26.1	Static components .....	36
26.2	Dynamic components .....	36
27	Physical characteristics .....	37
27.1	Dimensions .....	37
27.2	Mass .....	37
27.3	Cable assemblies .....	37
28	Design data .....	38
29	Indication of the characteristics to be specified.....	38
Annex A (informative)	Standard measuring enclosure type A .....	44
Annex B (informative)	Standard measuring enclosure type B .....	46
Annex C (informative)	Definitions of terms used in Clause 13 .....	49
Annex D (informative)	Listening tests .....	51
	Bibliography.....	51
	Figure 1 – Impedance curve of loudspeaker.....	15
	Figure 2 – Standard baffle, dimensions .....	40
	Figure 3 – Standard baffle with chamfer.....	41
	Figure 4 – Standard baffle with sub-baffle.....	41
	Figure 5 – Standard measuring enclosure type A .....	42
	Figure 6 – Standard measuring enclosure type B .....	42
	Figure 7 – Block diagram of test set-up.....	43
	Figure 8 – Measuring apparatus for stray magnetic field .....	43
	Figure A.1 – An example of standard measuring enclosure type A .....	44
	Figure A.2 – The correction curve for the diffraction effect of the standard measuring enclosure from free-field to half-space free-field .....	45
	Figure A.3 – The correction curve for the diffraction effect of a standard measuring enclosure from free-field to half-space free-field .....	45
	Figure B.1 – An example of standard measuring enclosure type B .....	46
	Figure B.2 – Construction of scalable measuring enclosure type B .....	47
	Figure B.3 – The correction curve for the diffraction effect of the standard measuring enclosure from free-field to half-space free-field .....	48
	Figure B.4 – The correction curve for the diffraction effect of the standard measuring enclosure from free-field to half-space free-field .....	48
	Table 1 – Indication of the characteristics to be specified .....	39
	Table B.1 – Dimensions and ratios of scalable enclosure type B.....	47

## SOUND SYSTEM EQUIPMENT –

### Part 5: Loudspeakers

#### 1 Scope

This standard applies to sound system loudspeakers, treated entirely as passive elements. Loudspeakers with built-in amplifiers are excluded.

NOTE 1 The term “loudspeaker” used in this standard relates to loudspeaker drive units themselves and also to loudspeaker systems, which comprise one or more loudspeaker drive units provided with a baffle, enclosure or horn and such relevant devices as built-in crossover filters, transformers and any other passive element.

The purpose of this standard is to give the characteristics to be specified and the relevant methods of measurement for loudspeakers using sinusoidal or specified noise or impulsive signals.

NOTE 2 The methods of measurement given in this standard have been chosen for their appropriateness to the characteristics.

NOTE 3 If equivalent results can be obtained using other methods of measurement, details of the methods used should be presented with the results.

NOTE 4 The following items are under consideration:

- loudspeakers with built-in amplifiers;
- measurements under conditions other than free-field, half-space free-field and diffuse field;
- measurements with signals other than sinusoidal or noise or impulsive signals.

#### 2 Normative references

The following referenced documents are indispensable for the application of this document. For dated references, only the edition cited applies. For undated references, the latest edition of the referenced document (including any amendments) applies.

IEC 60050(151), *International Electrotechnical Vocabulary (IEV) – Part 151: Electrical and magnetic devices*

IEC 60263, *Scales and sizes for plotting frequency characteristics and polar diagrams*

IEC 60268-1, *Sound system equipment – Part 1: General*

IEC 60268-2, *Sound system equipment – Part 2: Explanation of general terms and calculation methods*

IEC 60268-3, *Sound system equipment – Part 3: Amplifiers*

IEC 60268-11, *Sound system equipment – Part 11: Application of connectors for the interconnection of sound system components*

IEC 60268-12, *Sound system equipment – Part 12: Application of connectors for broadcast and similar use*

IEC 60268-14, *Part 14: Circular and elliptical loudspeakers; outer frame diameters and mounting dimensions*

IEC 60651, *Sound level meters*

IEC 61260, *Electroacoustics – Octave-band and fractional-octave-band filters*

ISO 3741, *Acoustics – Determination of sound power levels of noise sources using sound pressure – Precision methods for reverberation rooms*

ISO 3744, *Acoustics – Determination of sound power levels of noise sources using sound pressure – Engineering method in an essentially free field over a reflecting plane*

ISO 3745, *Acoustics – Determination of sound power levels of noise sources – Precision methods for anechoic and semi-anechoic rooms*

### 3 Conditions for measurement

#### 3.1 General conditions

This standard is to be used in conjunction with IEC 60268-1, IEC 60268-2 and ISO 3741.

#### 3.2 Measuring conditions

##### 3.2.1 General

For convenience in specifying how loudspeakers are to be set up for measurement, normal measuring conditions are defined in this standard. To obtain the correct conditions for measurement, some values (known as “rated conditions”) shall be taken from the manufacturer's specification. These values themselves are not subject to measurement but they constitute the basis for measuring the other characteristics.

The following values and conditions are of this type, and shall be stated by the manufacturer:

- rated impedance;
- rated sinusoidal voltage or power;
- rated noise voltage or power;
- rated frequency range;
- reference plane;
- reference point;
- reference axis.

NOTE A full explanation of the term “rated” is given in IEC 60268-2. See also term 151-04-03 in IEC 60050(151).

##### 3.2.2 Normal measuring conditions

A loudspeaker shall be understood to be working under normal measuring conditions when all the following conditions are fulfilled:

- a) the loudspeaker to be measured is mounted in accordance with Clause 10;
- b) the acoustical environment is specified and is selected from those specified in Clause 5;
- c) the loudspeaker is positioned with respect to the measuring microphone and the walls in accordance with Clause 7;
- d) the loudspeaker is supplied with a specified test signal, in accordance with Clause 4, of a stated voltage  $U$ , within the rated frequency range in accordance with 19.1. If required, the input power  $P$  can be calculated from the equation:  $P = U^2/R$ , where  $R$  is the rated impedance in accordance with 16.1;

- e) attenuators, if any, are set to their “normal” position as stated by the manufacturer. If other positions are chosen, for example those providing a maximally flat frequency response or maximum attenuation, these shall be specified;
- f) measuring equipment suitable for determining the wanted characteristics is connected in accordance with Clause 8.

## 4 Test signals

### 4.1 General

Acoustical measurements shall be made under one of the following measuring signal conditions, and the choice shall be indicated with the results.

### 4.2 Sinusoidal signal

The sinusoidal test signal shall not exceed the rated sinusoidal voltage (as defined in 17.4) at any frequency. The voltage across the input terminals of the loudspeaker under test shall be kept constant for all frequencies unless otherwise stated.

### 4.3 Broadband noise signal

NOTE This term is explained in IEC 60268-2.

The crest factor of a noise source should fall between 3 and 4 to avoid clipping of amplifiers.

A true r.m.s. voltmeter with a time constant at least as long as the “slow” constant of the sound level meter, specified in IEC 60651, shall be used to measure the amplitude of the signal.

### 4.4 Narrow-band noise signal

NOTE This term is explained in IEC 60268-2.

For measurement using narrow-band noise, constant relative bandwidth filters in accordance with IEC 61260 shall be used with a pink-noise generator, the relative bandwidth being usually 1/3 octave.

### 4.5 Impulsive signal

A short-duration pulse shall have constant spectral power per unit bandwidth over at least the bandwidth of interest in the measurement. Such a signal has low energy content relative to its peak amplitude.

NOTE To minimize the influence of acoustical and electrical noise on the measurement, the peak amplitude of the pulse should be as high as possible within the capability of the driving amplifier and consistent with linear operation of the loudspeaker.

## 5 Acoustical environment

### 5.1 General

Acoustical measurements shall be made under one of the acoustical field conditions specified in 5.2 to 5.6, and the choice shall be indicated with the results.



## 5.2 Free-field conditions

If acoustical conditions approach those of free-field space, an environment (for example an anechoic room) in which the sound pressure decreases with the distance ( $r$ ) from a point source according to a  $1/r$  law, with an accuracy of  $\pm 10\%$ , in the region that will be occupied by the sound field between the loudspeaker system and the microphone during the measurements shall be used. The minimum conditions shall be deemed to exist if this requirement is met along the axis joining the measuring microphone and the reference point on the loudspeaker.

Free-field conditions shall exist over the whole frequency range of measurement.

## 5.3 Half-space free-field conditions

If acoustical conditions are used in which the free-field exists in a half space, these conditions shall be met with a reflecting plane of sufficient size so that the sound pressure from a point source mounted in the surface of that plane decreases in the manner specified in 5.2.

## 5.4 Diffuse sound field conditions

NOTE 1 These conditions are normally used for band noise measurements only.

If diffuse sound field conditions are used for measurements with 1/3 octave band limited noise, as defined and specified in ISO 3741, the lower limiting frequency shall be determined as specified in ISO 3741, Appendix A.

NOTE 2 While ISO 3741 provides details of measuring instruments, it should be clearly understood that both space averaging and time averaging are required in loudspeaker power determination. This may be achieved as stated in the standard or alternatively by using continuous space and time averaging techniques.

NOTE 3 The precision of the measurement depends on a number of factors including the room volume, the room reverberation time, and the degree of diffusion.

NOTE 4 For measurement below 125 Hz, a room volume greater than 200 m<sup>3</sup> is desirable.

## 5.5 Simulated free-field conditions

If acoustical conditions are used in which the simulated free-field conditions that are equivalent to those of free space for the period of time required for a measurement, these conditions shall be used.

The conditions shall be met in any environment (for example large, unobstructed rooms) in which sound emitted by a loudspeaker in response to an impulsive signal reflected from any surface or object in the environment does not reach the measuring microphone before measurement of the direct path sound at the microphone has been completed.

Any such reflection reaching the microphone shall be excluded from the measurement by gating or other means.

NOTE 1 These conditions are normally used only for measurements with impulsive signals.

NOTE 2 Under such conditions, successive measurements are separated by time intervals sufficient for the sound pressure level due to reverberation within the space to decrease to a negligible value.

## 5.6 Half-space simulated free-field conditions

If acoustical conditions are used in which the simulated free-field exists in a half-space, these conditions shall be used when a reflecting plane, forming one boundary of a simulated free-field environment, is of sufficient size that no reflections from its edge reach the measuring microphone within the measurement time.

NOTE 1 These conditions are normally used only for measurements with impulsive signals.

NOTE 2 Under such conditions, successive measurements are separated by time intervals sufficient for the sound pressure level due to reverberation within the space to decrease to a negligible value.

## 6 Unwanted acoustical and electrical noise

Unwanted acoustical and electrical noise shall be kept at the lowest possible level as its presence may obscure low-level signals.

Data related to signals which are less than 10 dB above the noise level in the frequency band considered shall be discarded.

## 7 Positioning of loudspeaker and measuring microphone

### 7.1 Measuring distance under free-field and half-space free-field conditions

#### 7.1.1 General

Measurements under free-field and half-space free-field conditions should ideally be carried out in the far field of the loudspeaker, in order to obtain consistent results. However, in practice, imperfections of the measuring environment room and the effects of background noise set an upper limit to the distance that can be used. Therefore, the measuring distance should be 0.5 m or an integral number of m, and that result should be referred to a standard distance of 1 m.

#### 7.1.2 Single drive unit loudspeaker

For this type of loudspeaker, a measuring distance of 1 m from the reference point shall be used unless special conditions dictate another value, which shall be stated.

#### 7.1.3 Multi-unit loudspeaker systems

Loudspeaker systems in which two or more loudspeaker units reproduce the same frequency band create problems of acoustical interference at the measuring point due to the interaction of the sounds radiated by the units. This situation exists whether all units operate over the entire frequency band under test or whether some units operate over parts of this band (for example cross-over regions). In such cases, the measuring distance should be chosen so as to minimize the errors due to this phenomenon.

### 7.2 Positioning of loudspeaker in diffuse field conditions

The loudspeaker position and orientation with respect to the walls shall be described by means of a diagram appended to the measurement results.

An arrangement for the simultaneous movement of the loudspeaker and the microphone is permitted for the evaluation of the power delivered by the loudspeaker in accordance with the method prescribed in 22.1.2.2. The microphone system and the nearest microphone position shall meet the requirements of ISO 3741.

### 7.3 Positioning of loudspeaker and microphone in simulated free-field conditions

The measuring distance shall be chosen with reference to 7.1 for free-field conditions.

The position of the loudspeaker and microphone within the measuring environment shall be such so as to maximize the time available for measurement before the first unwanted reflection reaches the microphone.

If the measurement space is an anechoic chamber, attention shall be paid to reflections from wedge tips, personnel floor, and supports for the loudspeaker and microphone. Errors from these sources shall not exceed 0,5 dB over the frequency range of measurement.

The microphone distance and the maximum signal capture time available in the environment shall be stated.

It is necessary to ignore all the output of the microphone from the time of arrival of the first reflection onwards. Truncation errors are therefore introduced into the transfer-function measurement unless the loudspeaker response to the impulsive test signal is negligible during this time. If present, such truncation errors shall not exceed 1 dB over the frequency range of measurement.

## 8 Measuring equipment

Measurements in free-field and half-space free-field conditions shall be made using a pressure microphone having a known calibration. For measurements under diffuse-field conditions, a pressure microphone shall be used having a directivity index less than 2 dB. Both these requirements shall be met for all frequencies in the frequency range of interest.

The signal generator, the amplifier supplying the signal to the loudspeaker, and the measuring equipment at the microphone amplifier shall have an amplitude frequency response known and constant within  $\pm 0,5$  dB in the relevant frequency range, with negligible amplitude non-linearity under test conditions. All measuring instruments shall be of the r.m.s. type, having a time constant long enough to ensure an error not greater than 1 dB.

NOTE It is recommended that the frequency response be measured by an automatic method giving a continuous curve. Errors due to the chosen writing speeds (along both level and frequency axes) of the level recorder should not exceed 0,5 dB. The writing speeds along both axes should be stated.

## 9 Accuracy of the acoustical measurement

The frequency range over which the total errors do not exceed  $\pm 2$  dB shall be stated.

NOTE The probable error sources in both the instrumentation and the measuring environment should be identified and quantified and their contribution specified. This information should be included with the test report.

## 10 Mounting of loudspeakers

### 10.1 Mounting and acoustic loading of drive units

The performance of a drive unit is determined by the properties of the unit itself and its acoustic loading. The acoustic loading depends upon the mounting arrangement, which shall be clearly described in the presentation of results.

One of the following three types of mounting shall be used:

- a) a standard baffle, standard measuring enclosure (type A or type B), or specified enclosure;
- b) in free air without a baffle or enclosure;
- c) in half-space free-field, flush with the reflecting plane.

NOTE Mounting condition a) approaches that of a half-space free-field down to a lower limiting frequency, the value of which depends on the chosen measuring distance. Measurements made at frequencies below this limiting value may be used for comparative purposes only.

## 10.2 Mounting and acoustic loading of a loudspeaker system

Loudspeaker systems are usually measured without any additional baffle. If the manufacturer specifies a special type of mounting for the loudspeaker systems, this shall be used for the measurement; the mounting method used shall be specified with the results.

## 11 Standard baffle and measuring enclosures

### 11.1 Standard baffle

The standard baffle shall be made with a plane front surface that is acoustically reflective. The baffle shall have the dimensions shown in Figure 2.

NOTE The standard baffle should be of a material of thickness adequate to ensure negligible vibration. The edge of the radiating element should be substantially flush with the front surface of the baffle. This may be achieved by means of a chamfer as shown in Figure 3 or by the use of a thin rigid sub-baffle, with or without a chamfer, as shown in Figure 4.

### 11.2 Standard measuring enclosures

#### 11.2.1 General

One of the two types of standard measuring enclosures specified in 11.2.3 (type A) and 11.2.4 (type B) shall be used. The type chosen for testing shall be stated by the manufacturer.

#### 11.2.2 Conditions

The enclosure shall have plane or curved surfaces which have an acoustically reflective characteristic.

NOTE 1 The material shall be appropriately thick so that the effect of vibrations can be disregarded for measurement. If necessary, braces should be used for reinforcement between facing surfaces at and around their centres so as to avoid panel vibrations.

NOTE 2 The enclosure should be airtight.

NOTE 3 The edge of the loudspeaker should be set on the same plane as that of the front part of the baffle.

NOTE 4 To remove standing waves that may otherwise occur in the enclosure, an appropriate sound absorbing material shall be used. Handles or joints may be installed if their effect on acoustical reflections and undesired vibrations can be ignored.

NOTE 5 When the loudspeaker is mounted in the enclosure, care should be taken to avoid air leakage from the inside of the enclosure.

### 11.2.3 Standard measuring enclosure type A

The standard measuring enclosure type A shall be as shown in Figure 5.

NOTE 1 The characteristic of the correction curves for the standard measuring enclosure diffraction effect at a measuring distance of 1 m on the reference axis from free-field to half-space free-field is shown in Annex A.

NOTE 2 All the surfaces of this type of enclosure are plane and the joints of the surfaces are made at right angles. No change in size is allowed. This causes the diffraction characteristic to be repeatable. Therefore, type A is useful when analysing, studying or comparing the characteristics of loudspeakers in detail.

### 11.2.4 Standard measuring enclosure type B

The standard measuring enclosure type B shall be as shown in Figure 6.

NOTE 1 The characteristic of the correction curves for the standard measuring enclosure diffraction effect at a measuring distance of 1 m on the reference axis from free-field to half-space free-field is shown in Annex B.

NOTE 2 If a smaller or larger measuring enclosure of type B is required, it should meet the requirement for proportional scaling as shown in Annex B, Figure B.2 and Table B.1. In this case, the report should state the outside dimensions and the net volume of the enclosure.

NOTE 3 A change in scale is allowed. It is recommended to use the standard measuring enclosure as shown in Figure 6 for acoustical measurements. Properly scaled enclosures are useful for subjective testing.

## 12 Preconditioning

Permanent changes may take place in a loudspeaker as a result, for example, of motion of the diaphragm. Therefore, the loudspeaker should be preconditioned before measurements by application of a simulated programme signal, in accordance with IEC 60268-1, at the rated noise voltage for at least 1 h.

The period of preconditioning shall be followed by a recovery period of at least 1 h, during which the loudspeaker shall be disconnected, before proceeding with the measurement.

## 13 Type description

### 13.1 General

The type description shall be given by the manufacturer, as specified in 13.2 to 13.3.

NOTE See Table 1 and Annex C.

### 13.2 Loudspeaker drive units

#### 13.2.1 Principle of the transducer

The principle of the transducer shall be specified, for example, whether it is electrodynamic, electrostatic, or piezoelectric.

#### 13.2.2 Type

The type of the loudspeaker drive unit shall be specified, for example, direct radiating or horn, single or multi-unit.

### 13.3 Loudspeaker system

The number and type of drive units and acoustic loading principle shall be specified, for example, enclosure, horn, bass reflex, column or line.

## 14 Marking of terminals and controls

### 14.1 General

The terminals and controls shall be marked in accordance with IEC 60268-1 and IEC 60268-2 by the following principles.

### 14.2 Positive terminal

#### 14.2.1 Characteristic to be specified

The terminal of a drive unit (see Note 1 in Clause 1), to which the application of a positive voltage with respect to the other terminal results in an increase of sound pressure at the front of the drive unit shall be specified as the positive terminal.

#### 14.2.2 Marking

The positive terminal shall be marked with a + symbol, or a red marking, or in a way stated by the manufacturer.

#### 14.2.3 Method of test

Apply a positive d.c. voltage briefly to the terminal marked as positive. Examine the change of sound pressure at a point close to the front of the drive unit. Correct marking is confirmed by an increase of sound pressure.

NOTE 1 The increase of sound pressure is produced by a positive excursion, i.e., the loudspeaker diaphragm coming closer to the microphone.

NOTE 2 Any other method which produces the same result as the method described above can be used.

## 15 Reference plane, reference point and reference axis

NOTE 1 These are rated conditions in accordance with 3.2.1.

NOTE 2 Strictly speaking, these terms should include the word "rated" (for example rated reference plane), because they are specified by the manufacturer and cannot be measured. Nevertheless, confusion is unlikely if the shorter terms are used.

### 15.1 Reference plane – characteristic to be specified

The reference plane with respect to some physical feature of the loudspeaker drive unit or enclosure shall be specified by the manufacturer.

The reference plane shall be used to define the position of the reference point and the direction of the reference axis.

NOTE For symmetrical structures, the reference plane is usually parallel to the radiating surface or to a plane defining the front of the loudspeaker drive unit or system. For asymmetrical structures, the reference plane is better indicated by means of a diagram.

### 15.2 Reference point – characteristic to be specified

A point on the reference plane shall be specified by the manufacturer.

NOTE For symmetrical structures, the reference point is usually a point of geometric symmetry; for asymmetrical structures, the reference point is better indicated by means of a diagram.

### 15.3 Reference axis – characteristic to be specified

The line that passes through the reference plane at the reference point and its direction shall be specified by the manufacturer. The reference axis shall be used as the zero reference axis for directional and frequency response measurements.

NOTE For symmetrical structures, the reference axis is usually perpendicular to the radiating surface or to the reference plane.

## 16 Impedance and derivative characteristics

### 16.1 Rated impedance – characteristic to be specified

NOTE This is a rated condition in accordance with 3.2.1.

The value of a pure resistance which is to be substituted for the loudspeaker when defining the available electric power of the source shall be specified by the manufacturer.

The lowest value of the modulus of the impedance in the rated frequency range shall be not less than 80 % of the rated impedance. If the impedance at any frequency outside this range (including d.c.) is less than this value, this shall be stated in the specifications.

### 16.2 Impedance curve

#### 16.2.1 Characteristics to be specified

The impedance curve shall be specified, with representation of the modulus of the impedance as a function of frequency.

#### 16.2.2 Method of measurement

16.2.2.1 The loudspeaker shall be brought under normal measuring conditions in accordance with 3.2.2, conditions a), b) and d).

16.2.2.2 A constant voltage or current shall be supplied, the former usually being preferred. The value of voltage or current chosen for the measurement shall be sufficiently small to ensure that the loudspeaker operates in a linear region.

NOTE Measurements of impedance may be strongly influenced by the drive level. If the level is either too low or too high, inaccurate results may be obtained. The data should be examined for consistency at several drive levels in order to establish the best conditions.

16.2.2.3 The modulus of the impedance shall be measured at least over the frequency range 20 Hz to 20 000 Hz.

16.2.2.4 The results shall be presented graphically as a function of frequency. The value of the voltage or the current shall be stated with the results.

### 16.3 Total Q-factor ( $Q_t$ )

#### 16.3.1 Characteristic to be specified

The ratio of the inertial (or elastic) part of the acoustic or mechanical impedance at the resonance frequency, in accordance with 19.2, to the resistive part of this impedance shall be specified.

NOTE 1 For the purpose of this standard, the total Q-factor is defined for loudspeaker drive units and closed box loudspeakers, both of electrodynamic type only.

NOTE 2 The Q-factor  $Q_t$  together with the equivalent volume  $V_{as}$  in accordance with 16.4, of the loudspeaker unit and the resonance frequency  $f_r$  in accordance with 19.2 adequately define the low-frequency performance of the loudspeaker.

### 16.3.2 Method of measurement of total Q-factor ( $Q_t$ )

The total Q-factor  $Q_t$  can be derived from the electrical impedance curve of the loudspeaker in accordance with 16.2 using the expression:

$$Q_t = \frac{1}{r_0} \frac{f_r}{f_2 - f_1} \sqrt{\frac{r_0^2 - r_1^2}{r_1^2 - 1}}$$

where

- $f_r$  is the resonance frequency of the loudspeaker in accordance with 19.2;
- $r_0$  is the ratio of the maximum magnitude of the impedance,  $|Z(f)|_{\max}$ , at  $f_r$  to the d.c. resistance of the loudspeaker,  $R_{dc}$ ;
- $f_1$  and  $f_2$  are frequencies, located with approximate symmetry about  $f_r$  so that  $f_1 < f_r < f_2$ , at which the magnitude of impedances  $Z_1 = |Z(f_1)|$  and  $Z_2 = |Z(f_2)|$  are equal and have a value  $r_1 \times R_{dc}$ ;
- $r_1$  is the ratio of the magnitude  $|Z(f_1)|$  at  $f_1, f_2$  to  $R_{dc}$ .

NOTE 1 See Figure 1.

It can be shown that when  $r_1 = \sqrt{f_1 f_2}$  and  $f_r$  is replaced by  $\sqrt{f_1 f_2}$ , the error in calculation of  $Q_t$  due to the asymmetry of the impedance curve is minimized (see Note 2). The expression for  $Q_t$  may then be simplified to:

$$Q_t = \frac{\sqrt{f_1 f_2}}{\sqrt{r_0} (f_2 - f_1)}$$

NOTE 2  $Q_t$ , which appears in the above formulae, has been derived from simple theory in which the voice-coil inductance, which is the cause of the asymmetry in the impedance curve, has been ignored.

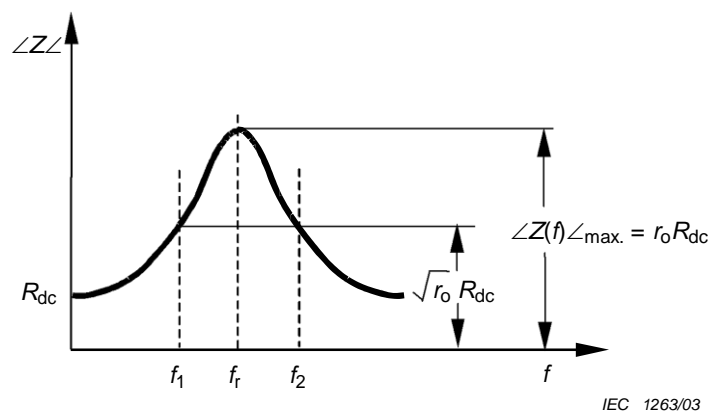

Figure 1 – Impedance curve of loudspeaker



## 16.4 Equivalent air volume of a loudspeaker drive unit compliance ( $V_{as}$ )

### 16.4.1 Characteristic to be specified

The volume of air shall be specified, the acoustic compliance of which is equal to that of the loudspeaker unit.

NOTE The equivalent volume  $V_{as}$ , together with the total Q-factor,  $Q_t$ , in accordance with 16.3, and the resonance frequency,  $f_r$ , in accordance with 19.2, adequately define the low frequency performance of the loudspeaker and are useful in the low frequency design of enclosure and bass reflex loudspeaker systems.

### 16.4.2 Method of measurement

**16.4.2.1** Mount the loudspeaker drive unit in an unlined rigid test enclosure of the following characteristics:

- the enclosure shall be of size and shape appropriate to the size of the driver and any intended application.
- It shall contain a simple vent-hole that can be filled by a flanged plug thus converting the vented or reflex box into a well-sealed enclosure.

**16.4.2.2** With the vent closed, measure the system resonance frequency,  $f_0$ , as the lowest frequency above zero, of zero phase of the input impedance.

NOTE 1 This can be done by driving the loudspeaker via a series resistance and applying the voltages across the resistor and the loudspeaker to the horizontal and vertical plates of an oscilloscope. Zero phase is indicated by the elliptical pattern collapsing to a straight line.

NOTE 2 See the note to 16.2.2.2.

**16.4.2.3** With the vent open, measure the first three frequencies of zero phase, above zero, in an ascending frequency scale. Let these be  $f_L$ ,  $f_B$  and  $f_H$ . (The frequency  $f_B$  occurs near the point of minimum impedance and is the actual enclosure resonance frequency as modified by the presence of voice-coil inductance. It should be noted but not used.). The true resonance frequency  $f_{B0}$  (which would apply in the absence of voice-coil inductance, enabling the simplified theory to be applied) shall then be calculated from the formula:

$$f_{B0} = \sqrt{f_L^2 + f_H^2 - f_0^2}$$

**16.4.2.4** The true driver resonance frequency that would apply to the driver mounted on an infinite baffle in free air shall be given by:

$$f_{r0} = \frac{f_L f_H}{f_{B0}}$$

**16.4.2.5** The value of the equivalent air volume of the loudspeaker compliance shall be given by:

$$V_{AS} = V_B \left( \frac{f_0}{f_{r0}} \right)^2 - 1$$

where  $V_B$  is the net internal volume of tested enclosure.

## 17 Input voltage

### 17.1 Rated noise voltage

NOTE This is a rated condition in accordance with 3.2.1.

#### 17.1.1 Characteristic to be specified

The voltage of a noise signal, simulating normal program, which the loudspeaker can handle without any thermal or mechanical damage shall be specified by the manufacturer.

NOTE This value depends upon the way the loudspeaker is mounted, for example unmounted or mounted in a specified enclosure.

#### 17.1.2 Method of measurement

**17.1.2.1** The following equipment or equivalent shall be included in the chain of measurement:

- a pink noise generator;
- a suitable weighting network to obtain the noise signal in accordance with IEC 60268-1;
- a power amplifier with clipping network;
- the loudspeaker under test, mounted as specified, loudspeaker drive units shall be tested without baffle, unless an enclosure is specified by the manufacturer.

NOTE 1 If more than one loudspeaker is tested simultaneously, care should be taken to ensure that interaction between the loudspeakers is not significant.

NOTE 2 If a loudspeaker is designed to operate in a restricted frequency range and a corresponding network for frequency limitation is not an integral part of that loudspeaker, an adequate network, which is to be connected to the loudspeaker during the test should be specified by the manufacturer. This network then forms an integral part of the loudspeaker and the rated impedance should be related to the input terminals of this network, its output being loaded by the loudspeaker.

NOTE 3 The order in which the elements in the chain are connected should be as shown in Figure 7. The loudspeaker shall be placed in a room of not less than 8 m<sup>3</sup>, in which the climatic conditions specified in IEC 60268-1 have been obtained.

**17.1.2.2** The frequency response of the power amplifier, when measured at the input terminals of the loudspeaker under test, shall be constant to within  $\pm 0,5$  dB in the frequency range 20 Hz to 20 000 Hz. The clipped noise at the terminals of the loudspeaker under test shall have a frequency distribution as specified in IEC 60268-1, and a peak-to-r.m.s. ratio between 1,8 and 2,2.

**17.1.2.3** The power amplifier shall have an output impedance not greater than one third of the rated impedance of the loudspeaker system in accordance with 16.1. The amplifier shall be capable of supplying the loudspeaker with a peak voltage of sinusoidal signal without clipping. That peak voltage is at least twice that of the test noise voltage.

**17.1.2.4** The loudspeaker shall be tested under each specified climatic condition for a continuous period of 100 h at a rated voltage corresponding to that which the loudspeaker is required to handle.

**17.1.2.5** Immediately after the test, the loudspeaker shall be stored under climatic conditions such as normally exist in ordinary rooms or laboratories. Unless otherwise specified, the recovery period shall be 24 h.

**17.1.2.6** A loudspeaker should be deemed to have fulfilled the requirements of this test if, at the end of the storage period, there is no significant change in the electrical, mechanical and acoustical characteristics of the loudspeaker itself compared with those stated in the data sheet for the loudspeaker type, other than a change in the resonance frequency.

NOTE The acceptability of this change is subject to negotiation; it should therefore be stated.

### **17.1.3 Listening test for normal operation**

A listening test for normal operation may be conducted according to Annex D.

## **17.2 Short-term maximum input voltage**

### **17.2.1 Characteristic to be specified**

**17.2.1.1** The maximum voltage which the loudspeaker drive-unit or system can handle, without causing permanent damage, for a period of 1 s when the signal is a noise signal simulating normal programme material (in accordance with IEC 60268-1) shall be specified.

**17.2.1.2** The test shall be repeated 60 times with intervals of 1 min.

### **17.2.2 Method of measurement**

The method of measurement for rated noise voltage specified in 17.1.2 shall be used except that the test signal shall be produced by a gated source of weighted noise signal that simulates normal program material (in accordance with IEC 60268-1).

NOTE The r.m.s. value of the voltage applied to the loudspeaker during the on-period may be conveniently measured by removing the gating action and measuring the r.m.s voltage of the continuous noise signal, the loudspeaker being replaced by a resistor equal in value to the rated impedance of the loudspeaker.

### **17.2.3 Protective devices**

**17.2.3.1** If the loudspeaker is fitted with a protective device, the short-term maximum input voltage shall be taken as the input voltage applied for the specified period of time that causes the protective device itself to operate.

**17.2.3.2** If the operation of a protective device causes the load impedance presented by the loudspeaker to the amplifier to decrease to less than 80 % of the rated impedance at any frequency, the minimum value of the loudspeaker input impedance shall be stated by the manufacturer.

## **17.3 Long-term maximum input voltage**

### **17.3.1 Characteristic to be specified**

**17.3.1.1** The maximum voltage which the loudspeaker drive unit or system can handle, without causing permanent damage, for a period of 1 min when the signal is a noise signal simulating normal programme material (in accordance with IEC 60268-1) shall be specified.

**17.3.1.2** The test shall be repeated 10 times with intervals of 2 min.

### 17.3.2 Method of measurement

The method of measurement for rated noise voltage as described in 17.1.2 shall be used except that the test signal shall be produced by a gated source of weighted noise signal that simulates normal program material (in accordance with IEC 60268-1).

NOTE The r.m.s. value of the voltage applied to the loudspeaker during the on-period may be conveniently measured by removing the gating action and measuring the r.m.s. voltage of continuous noise signal, the loudspeaker being replaced by a resistor equal in value to the rated impedance of the loudspeaker.

### 17.3.3 Protective devices

**17.3.3.1** If the loudspeaker is fitted with a protective device, the long-term maximum input voltage shall be taken as the input voltage applied for the specified period of time which causes the protective device itself to operate.

**17.3.3.2** If the operation of a protective device causes the load impedance presented by the loudspeaker to the amplifier to decrease to less than 80 % of the rated impedance at any frequency, the minimum value of the loudspeaker input impedance shall be stated by the manufacturer.

### 17.4 Rated sinusoidal voltage

NOTE This is a rated condition in accordance with 3.2.1.

#### 17.4.1 Characteristic to be specified

The voltage of a continuous sinusoidal signal within the rated frequency range, which the loudspeaker can handle continuously without any thermal or mechanical damage shall be specified by the manufacturer.

NOTE 1 This value can vary as a function of frequency, in which case different values may be given in specified frequency ranges.

NOTE 2 These values depend on the way the loudspeaker is mounted in accordance with Clause 10.

#### 17.4.2 Method of measurement

The method of measurement for rated noise voltage in 17.1.2 shall be used except that the test signal source shall be a sinusoidal signal. The method shall be valid for determining the upper input voltage limit for measurement during a specified period of time. If no period of time is specified, a maximum of 1 h shall be used.

#### 17.4.3 Listening test for mechanical noise (rattles)

A listening test for mechanical noise (rattles) may be conducted according to Annex D.

## 18 Input electrical power

### 18.1 Rated noise power – characteristic to be specified

NOTE 1 This is a rated condition in accordance with 3.2.1.

The electrical power calculated from the formula  $U_n^2/R$  shall be specified, where  $U_n$  is the rated noise voltage and  $R$  is the rated impedance.

NOTE 2 The rated noise power may also be called “power handling capacity”.

**18.2 Short-term maximum power – characteristic to be specified**

The electrical power corresponding to the short-term maximum input voltage, defined as  $U_{st}^2/R$ , shall be specified where  $U_{st}$  is the short-term maximum input voltage and  $R$  is the rated impedance.

**18.3 Long-term maximum power – characteristic to be specified**

The electrical power corresponding to the long-term maximum input voltage, defined as  $U_{lt}^2/R$  shall be specified where  $U_{lt}$  is the long-term maximum input voltage and  $R$  is the rated impedance.

**18.4 Rated sinusoidal power – characteristic to be specified**

NOTE This is a rated condition in accordance with 3.2.1.

The electrical power calculated from the formula:  $U_s^2/R$  shall be specified, where  $U_s$  is the rated sinusoidal voltage and  $R$  is the rated impedance.

**19 Frequency characteristics****19.1 Rated frequency range – characteristic to be specified**

NOTE 1 This is a rated condition in accordance with 3.2.1.

The range of frequencies at which the loudspeaker is intended to be used shall be specified.

NOTE 2 The rated frequency range may differ from the effective frequency range particularly in the case of loudspeakers used only as tweeters or woofers, or only for speech.

**19.2 Resonance frequency****19.2.1 Resonance frequency of a loudspeaker drive unit – characteristic to be specified**

The frequency at which the modulus of the electrical impedance has its first principal maximum on an ascending frequency scale shall be specified. The acoustical environment (either free-field or half-space free-field), and the mounting conditions, including the characteristics of the measuring enclosure when used, shall be given with the value of this frequency.

NOTE Loudspeaker drive units may be mounted in accordance with 10.1.

**19.2.2 Resonance frequency of a closed box loudspeaker system – characteristic to be specified**

The frequency at which the impedance curve has its first principal maximum in an ascending frequency scale, including any crossover networks shall be specified.

**19.3 Tuning frequency of a bass reflex or passive radiator loudspeaker system – characteristic to be specified**

The frequency at which the modulus of the impedance has its first principal minimum, following its first principal maximum in an ascending frequency scale including any cross-over networks shall be specified.

## 20 Sound pressure under free-field and half-space free-field conditions

### 20.1 Sound pressure in a stated frequency band

#### 20.1.1 Characteristic to be specified

The sound pressure produced at a stated distance from the reference point on the reference axis when the loudspeaker is supplied with a pink noise signal in a stated frequency band at a specified voltage shall be specified.

#### 20.1.2 Method of measurement

**20.1.2.1** The loudspeaker shall be brought under normal measuring conditions in a free-field or half-space free-field environment. Half-space free-field shall apply only to driver units mounted flush with the reflecting surface.

**20.1.2.2** The following equipment shall be included in the chain of measurement:

- the loudspeaker under test;
- a pink noise generator;
- a band-pass filter having slopes of at least 24 dB/octave which limits the bandwidth of the signal to that over which the loudspeaker is to be measured.

**20.1.2.3** A pink noise signal of a stated voltage  $U_p$  and bandwidth shall be supplied to the loudspeaker.

**20.1.2.4** The sound pressure shall be measured at a stated distance. In those cases where a filter having a bandwidth equal to the stated frequency band is not available, an approximation may be made by dividing this frequency band into  $n$  sets of 1/3 octave bands in accordance with IEC 61260, the 1/3 octave filters being fed with the pink noise signal. Then the voltage fed to the loudspeaker under test in each 1/3 octave frequency band shall be equal to  $U_p / \sqrt{n}$ . This sound pressure is given by the formula:

$$p_r = \left| \sum_{i=1}^{i=n} (p_i)^2 \right|^{1/2}$$

where  $p_i$  is the sound pressure in a given 1/3 octave band.

**20.1.2.5** The conditions shall be stated with the results.

### 20.2 Sound pressure level in a stated frequency band – characteristic to be specified

Twenty times the logarithm of the ratio of the sound pressure, measured in accordance with 20.1.1, to the standard reference sound pressure (20  $\mu$ Pa), shall be specified, expressed in dB.

### 20.3 Characteristic sensitivity in a stated frequency band

#### 20.3.1 Characteristic to be specified

The sound pressure output shall be specified in a stated frequency in accordance with 20.1.1, referred to an input power of 1 W and to a distance of 1 m on the reference axis.

### 20.3.2 Method of measurement

Measurements shall be made in accordance with 20.1.2, and they shall be referred to voltage  $U_p$  corresponding to a power of 1 W, where  $U_p$  is numerically equal to the  $\sqrt{R}$  value and where  $R$  is the rated impedance.

### 20.4 Characteristic sensitivity level in a stated frequency band – characteristic to be specified

Twenty times the logarithm of the ratio of the characteristic sensitivity in accordance with 20.3.1 to the standard reference sound pressure (20  $\mu$ Pa) shall be specified expressed in dB.

### 20.5 Mean sound pressure in a stated frequency band

#### 20.5.1 Characteristic to be specified

The square root of the arithmetic mean of the squares of the sound pressures from all the 1/3 octave frequency bands in a frequency band shall be specified.

#### 20.5.2 Method of measurement

Measurements shall be made in accordance with 20.1.2, except that the voltage fed to the loudspeaker under test in each 1/3 octave frequency band shall be equal to  $U_p$ . The mean sound pressure in a stated frequency band shall be determined by the formula:

$$p_m = \frac{p_r}{\sqrt{W}}$$

NOTE See 20.1.2.4 for the formula to use in determining the value of  $p_r$ .

### 20.6 Mean sound pressure level in a stated frequency band – characteristic to be specified

Twenty times the logarithm of the ratio of  $p_m$ , in accordance with 20.5.2, to the standard reference sound pressure (20  $\mu$ Pa) shall be specified expressed in dB.

## 21 Response under free-field and half-space free-field conditions

### 21.1 Frequency response

#### 21.1.1 Characteristic to be specified

The sound pressure level shall be specified as a function of frequency, measured under free-field or half-space free-field conditions at a stated position with respect to the reference axis and a point at a specified constant voltage, either with sinusoidal or with band noise signals.

#### 21.1.2 Method of measurement

**21.1.2.1** The loudspeaker shall be brought under normal measuring conditions in a free-field or half-space free-field environment.

**21.1.2.2** A band noise or a sinusoidal signal of constant voltage shall be supplied to the loudspeaker.

**21.1.2.3** Measurements shall be made over at least the effective frequency range in accordance with 21.2.

Measurements with band-filtered noise shall be performed either:

- a) by supplying the loudspeaker with a pink noise (limited to the effective frequency range of the loudspeaker) and analysing the microphone output signal by means of 1/3 octave filters; or,
- b) by supplying the loudspeaker with a narrow band noise signal in accordance with 4.3.

NOTE If method b) is adopted, filters are not necessary in the microphone chain, but there should be no restriction against their use.

**21.1.2.4** The results shall be presented as a graph as a function of frequency. The space condition and the band-filtered noise measurement chosen shall be stated.

### **21.1.3 Measurement correction at low frequencies**

If the low-frequency absorption characteristic of an anechoic room causes a deviation from free-field conditions such that accurate measurement of free-field response down to the lower limit of the effective frequency range in accordance with 21.2 is not possible, the low-frequency measurement results shall be corrected as follows.

**21.1.3.1** The loudspeaker under test shall be removed from the room and replaced by a calibrated reference loudspeaker located so that its reference point and reference axis take the positions previously occupied by those of the loudspeaker under test.

The reference loudspeaker shall have substantially the same directional characteristics as the loudspeaker under test over the frequency range where correction is required, and its calibrated free-field frequency response shall extend to the lowest frequency of interest.

NOTE 1 It is necessary to determine the frequency response of the reference loudspeaker accurately. For reference loudspeakers with limited low-frequency response (main resonance above 150 Hz), measurements in a very large anechoic room (for example 8 m × 10 m × 12 m) can be sufficiently accurate. For loudspeakers with extended low-frequency response, measurements on a tower (typically 10 m or more above ground level) in the open air can become necessary.

NOTE 2 For measurement of the low-frequency response of a multi-unit loudspeaker system, the reference point is ideally the reference point of the bass unit.

**21.1.3.2** The frequency response of the reference loudspeaker shall be measured using the same equipment and technique as for the loudspeaker under test in accordance with 21.1.2.

**21.1.3.3** Over the low-frequency range where the frequency response thus measured for the reference loudspeaker deviates from its known calibrated free-field response, the difference between the calibrated and measured responses shall be used to correct the measured response of the loudspeaker under test.

## **21.2 Effective frequency range**

### **21.2.1 Characteristic to be specified**

The range of frequencies, bounded by stated upper and lower limits, for which the frequency response of the loudspeaker in accordance with 21.1.2, measured on the reference axis with a sinusoidal signal is not more than 10 dB below the sound pressure level averaged over a bandwidth of one octave in the region of maximum sensitivity or a broader bandwidth stated by the manufacturer, shall be specified. Sharp troughs in the response curve, narrower than 1/9 octave (one-third of 1/3 octave) at –10 dB level shall be neglected in determining the frequency limits.



### 21.2.2 Method of measurement

The effective frequency range may be obtained from the frequency response described in 21.1.1, measured with sinusoidal signals only.

## 21.3 Transfer function

### 21.3.1 Characteristic to be specified

The sound pressure amplitude level and phase versus frequency shall be specified, measured under free-field or simulated free-field conditions, at a stated position with respect to the reference axis and point, for a specified constant voltage at the loudspeaker terminals. Unless otherwise stated, this voltage shall be 1 V.

The signal level used shall ensure that the measurement result is unaffected by non-linearity.

The sound pressure amplitude level is normally expressed as the equivalent sound pressure level. In presenting the phase as a function of frequency, phase shift related to propagation delay between loudspeaker and microphone shall be removed.

### 21.3.2 Method of measurement

**21.3.2.1** The loudspeaker shall be brought under normal measuring conditions in a simulated free-field environment.

**21.3.2.2** An impulsive test signal with a spectral bandwidth at least as great as the frequency range of interest shall be supplied to the loudspeaker.

NOTE To achieve an adequate signal-to-noise ratio the test signal may be repeated, allowing sufficient time between repetitions for the sound pressure level due to reverberation to decrease to a negligible value, and the results averaged. In order to minimize the measurement time required, spectral shaping (pre-emphasis) may be applied to the test signal and complementary correction (de-emphasis) to the measured sound pressure.

**21.3.2.3** The sound pressure shall be measured under the conditions of 21.3.2.1 and 21.3.2.2, and the results expressed as a function of frequency. This is normally obtained by sampling and digitizing the sound pressure signal and performing a Fourier transform in a digital Fourier analyser or computer. The method of transforming the measured signal into the frequency domain shall not introduce errors exceeding 0,1 dB in the calculated sound pressure level result over the frequency range.

**21.3.2.4** The voltage applied to the loudspeaker terminals shall be measured, via a calibrated frequency-independent attenuator and the microphone signal measuring chain, with any pre-emphasis and de-emphasis elements included, and the results expressed as a function of frequency as in 21.3.2.3.

**21.3.2.5** The loudspeaker transfer function shall be the measurement result of the procedure specified in 21.3.2.3, divided by the measurement result of the procedure specified in 21.3.2.4, the microphone sensitivity and attenuator calibration having been taken into account. This function shall be presented as a plot of magnitude and phase as a function of frequency, with the magnitude expressed as the equivalent sound pressure level for an input power of 1 W.

## 22 Output power (acoustic power)

### 22.1 Acoustic power in a frequency band

#### 22.1.1 Characteristic to be specified

The total sound power radiated by a loudspeaker in a given frequency band with centre frequency  $f$  for a defined input signal shall be specified.

#### 22.1.2 Method of measurement

##### 22.1.2.1 General

**22.1.2.1.1** The loudspeaker shall be brought under normal measuring conditions in a free-field, a half-space free-field or a diffuse field environment. Depending on the environment chosen, the measurement shall be carried out by one of the methods given in 22.1.2.2 and 22.1.2.3.

**22.1.2.1.2** The results shall be presented graphically as a function of frequency.

##### 22.1.2.2 Measurement of acoustic power under free-field or half-space free-field conditions

**22.1.2.2.1** The square of the r.m.s. sound pressure shall be averaged over a large sphere in the case of free-field conditions, and over a large hemisphere in accordance with ISO 3744 or ISO 3745, in the case of half-space free-field conditions, at a large number of points evenly distributed around the system under measurement.

**22.1.2.2.2** If the system has axial symmetry of revolution, measurements in a plane containing this axis may be considered sufficient, provided that the measurements are suitably weighted in the averaging process.

**22.1.2.2.3** The acoustic power under free-field conditions shall be determined by the formula:

$$P_a(f) = \frac{4\pi r^2}{\rho_0 c} p^2(f) = 0,031r^2 p^2(f)$$

where:

$P_a(f)$  is the acoustic power, in W;

$r$  is the sphere radius, in m;

$p(f)$  is the sound pressure averaged over a large sphere, in Pa;

$\rho_0$  and  $c$  are the density and the sound velocity of the air.

The acoustic power under half-space free-field conditions shall be determined by the formula:

$$P_a(f) = \frac{2\pi r^2}{\rho_0 c} p^2(f) = 0,016r^2 p^2(f)$$

##### 22.1.2.3 Measurement of acoustic power under diffuse field conditions

**22.1.2.3.1** The sound pressure in the frequency band of mid-band frequency  $f$  shall be determined in accordance with 20.1.2.

**22.1.2.3.2** The acoustic power of the loudspeaker  $P_a(f)$  shall be given approximately by the relation:

$$P_a(f) = \frac{V}{T(f)} p^2(f) 10^{-4}$$

where:

$P_a(f)$  is the acoustic power, in W;

$V$  is the reverberation room volume, in m<sup>3</sup>;

$T(f)$  is the reverberation time of the room in the frequency band considered, in seconds;

$p(f)$  is the sound pressure, in Pa.

NOTE 1 The filtering may take place either in the loudspeaker chain or in both the loudspeaker and the microphone chains.

NOTE 2 An alternative method for measuring the sound power of loudspeakers, using a sound power source, is described in ISO 3743-1 and in ISO 3743-2.

## **22.2 Mean acoustic power in a frequency band**

### **22.2.1 Characteristic to be specified**

The arithmetic mean of the acoustic power in all 1/3 octave frequency bands in the frequency band considered shall be specified.

### **22.2.2 Method of measurement**

**22.2.2.1** The measurement shall be made in accordance with 22.1.2.

**22.2.2.2** The mean acoustic power shall be calculated as the arithmetic mean of the acoustic power measured individually for all the 1/3 octave frequency bands included in the frequency range considered.

## **22.3 Efficiency in a frequency band**

### **22.3.1 Characteristic to be specified**

The ratio  $f$  of the acoustic power radiated by a loudspeaker to the electrical power supplied in a frequency band of mid frequency shall be specified.

### **22.3.2 Method of measurement**

Efficiency in a frequency band shall be measured by the following method:

- a) the measurement shall be made in accordance with 22.1.2;
- b) the electrical power shall be determined in accordance with 3.2.2;
- c) the efficiency in a frequency band shall be given as the ratio of the acoustic power to the electrical power.

## **22.4 Mean efficiency in a frequency band**

### **22.4.1 Characteristic to be specified**

The arithmetic mean of the efficiency in all the 1/3 octave frequency bands in the frequency band concerned shall be specified.

## 22.4.2 Method of measurement

22.4.2.1 The efficiency in the frequency band shall be determined in accordance with 22.3.2.

22.4.2.2 The mean efficiency shall be calculated as the arithmetic mean of the efficiencies measured in each of the 1/3 octave bands covering the frequency range required.

## 23 Directional characteristics

### 23.1 Directional response pattern

#### 23.1.1 Characteristic to be specified

The sound pressure level shall be specified as a function of the angle between the measuring axis and the reference axis, and of frequency of the radiated sound. The measuring axis shall be the line joining the microphone to the reference point.

#### 23.1.2 Method of measurement

23.1.2.1 The loudspeaker shall be brought under normal measuring conditions in a free-field environment.

23.1.2.2 The measuring microphone shall be positioned in a specific plane, containing the reference axis, at a specified distance from the reference point.

23.1.2.3 Either a sinusoidal or a band noise signal shall be used. It shall be applied to the loudspeaker. The input voltage shall be adjusted for each frequency or band so that the sound pressure at a specified point on the reference axis is kept constant.

23.1.2.4 One of the following ways may be chosen for displaying the directional response pattern:

- a) a family of polar response curves at stated frequencies or frequency bands shall be displayed;

NOTE 1 Preferably 1/3 octave or one octave, over the rated frequency range. However for at least the following frequencies: 500 Hz, 1 000 Hz, 2 000 Hz, 4 000 Hz and 8 000 Hz; a device should be used that provides a continuous change in angular deviation.

- b) a family of frequency response curves at various angles from the reference axis shall be displayed.

NOTE 2 Angles at 15° intervals should be used.

NOTE 3 See AES information document AES-5id-1997.

23.1.2.5 Results of the measurement for 23.1.2.4 a) shall be plotted as polar curves in accordance with IEC 60268-1 and IEC 60263.

NOTE 1 Great care is needed to ensure that significant lobes are adequately explored. In presenting the results, the orientation of the measuring axis with respect to the reference axis shall be stated. If a point-by-point method is used, the graph shall clearly show the angles used.

NOTE 2 For very small loudspeakers such as tweeters, it may be necessary to use higher frequencies outside those mentioned above. These frequencies should conform to those given in IEC 60268-1.

NOTE 3 Care should be taken that the level on the reference axis of the loudspeaker corresponds to the zero level of the polar diagram.

## 23.2 Radiation angle

### 23.2.1 Characteristic to be specified

The angle, measured with respect to the reference axis in a plane containing this axis shall be specified such that the sound pressure level within the angle at the measuring distance decreases by less than 10 dB with respect to the sound pressure level on the reference axis. The frequency range over which this specification is met shall be stated.

### 23.2.2 Method of measurement

**23.2.2.1** The radiation angle shall be deduced from the directional response pattern in the rated frequency range, measured in accordance with 23.1.2.4 a).

**23.2.2.2** If the directional response pattern of the loudspeaker has no cylindrical symmetry, the value shall be given in two perpendicular planes.

NOTE The radiation angle may be plotted as a graph with frequency as abscissa and the angles on the ordinate, symmetrical with respect to 0°.

## 23.3 Directivity index

### 23.3.1 Characteristic to be specified

The ratio of the following two sound pressure values, expressed in dB, shall be specified:

- the sound pressure measured at a chosen point on the reference axis;
- the sound pressure that a point source radiating the same acoustic power as the loudspeaker under test would produce at the same measuring position under free-field conditions.

### 23.3.2 Method of measurement

The directivity index  $D$  shall be determined in accordance with either 23.3.2.1 or 23.3.2.2.

#### 23.3.2.1

- a) The sound pressure level ( $L_{ax}$ ) shall be measured in accordance with 20.1.2 in a free-field environment and at a distance of 1 m.
- b) The sound pressure level shall be measured under diffuse field conditions ( $L_p$ ).
- c) In both measurements, the loudspeaker shall be supplied with the same stated voltage of filtered pink noise.

d) The directivity index ( $D_i$ ) shall be determined from the formula:

$$D_i = L_{ax} - L_p + 10 \lg \left( \frac{T}{T_0} \right) - 10 \lg \left( \frac{V}{V_0} \right) + 25 \text{ dB}$$

where:

$L_{ax}$  is the sound pressure level under free-field conditions, measured on the reference axis and referred to a distance of 1 m;

$L_p$  is the sound pressure level measured under diffuse field conditions;

$T$  is the reverberation time of the reverberation room, in s;

$T_0$  is a reference reverberation time of 1 s;

$V$  is the reverberation room volume, in  $\text{m}^3$ ;

$V_0$  is a reference volume of 1  $\text{m}^3$ ;

25 is an approximate value related to constant factors in the SI system of units

### 23.3.2.2

- The squares of the sound pressure taken from the polar curves in accordance with 23.1.2.4 a) shall be integrated over a sphere, to give a mean value  $s_m$  by using one of the methods given in 22.1.2.2 and 22.1.2.3.
- The square of the sound pressure on the axis shall be determined,  $s_0$ .
- The directivity index  $D_i$  shall be specified as ten times the logarithm of the ratio of  $s_0$  to  $s_m$ .

## 23.4 Coverage angle or angles

### 23.4.1 Characteristic to be specified

The angle between the two directions on either side of the main lobe of the directional response pattern, at which the sound pressure level is 6 dB less than that at the direction of maximum level, shall be specified.

The angle shall be measured in a plane containing the reference axis.

The directional response pattern shall be measured with octave band noise centred on a specified frequency in accordance with 23.1.

For loudspeakers which are designed to have different coverage angles in different planes through the reference axis, coverage angles shall be specified in at least two orthogonal planes in accordance with 23.2.2.2.

### 23.4.2 Method of measurement

The coverage angle or angles shall be deduced from the directional response pattern or patterns measured with an octave band centred on 4 000 Hz, if the effective frequency range of the loudspeaker includes both 2 800 Hz and 5 700 Hz (1/2 octave above and below 4 000 Hz).

If the effective frequency range does not include the octave band centred on 4 000 Hz, the coverage angle or angles shall be deduced from measurements in an octave band of specified centre frequency, near the upper limit of the effective frequency range.

The coverage angle or angles may, in addition, be specified for other centre frequencies of octave bands.

The centre frequency or frequencies used for the measurements shall be presented with the measured data.

NOTE An approximate relation between the coverage angles and the directivity index in the same octave band may be specified by:

$$D_i = 10 \lg \left| \frac{180}{\arcsin \{ \sin(A/2) \sin(B/2) \}} \right|$$

where  $A$  and  $B$  are the coverage angles in degrees in two orthogonal planes.

## 24 Amplitude non-linearity

NOTE A general explanation on amplitude non-linearity can be found in IEC 60268-2. The characteristics to be specified and the methods of measurement of various types of amplitude non-linearity, which can be of importance for loudspeakers, are prescribed in subclauses 24.1 to 24.6.

### 24.1 Total harmonic distortion

#### 24.1.1 Characteristic to be specified

The total harmonic distortion shall be specified, expressed in terms of total sound pressure  $p_t$ .

#### 24.1.2 Method of measurement for input voltages up to the rated sinusoidal voltage

24.1.2.1 The loudspeaker shall be brought under free-field conditions for loudspeaker systems and in half-space free-field conditions for loudspeaker drive units. A series of sinusoidal input voltages with increasing frequencies up to 5 000 Hz, shall be supplied to the loudspeaker. The input voltages chosen shall not exceed the rated sinusoidal voltage in accordance with 17.4. The range of frequencies shall be covered by means of gliding tones, because a step-by-step method may cause important information to be missed.

24.1.2.2 A measuring microphone shall be situated 1 m from the reference point, unless otherwise specified.

24.1.2.3 A selective voltmeter, such as a wave analyser, preceded, if necessary, by a high-pass filter which suppresses the fundamental, shall be connected to the measuring microphone.

24.1.2.4 The sound pressure of the separate harmonics  $p_{nf}$  shall be measured.

24.1.2.5 The total sound pressure  $p_t$ , including the fundamental, shall be measured by a wide band meter connected to the microphone. The meter shall indicate the true r.m.s. value of the harmonic.

24.1.2.6 The total harmonic distortion shall be determined by the formula:

in %:

$$d_t = \frac{\sqrt{p_{2f}^2 + p_{3f}^2 + \dots + p_{nf}^2}}{p_t} \times 100 \%$$

in dB:

$$L_{dt} = 20 \lg \frac{d_t}{100}$$

**24.1.2.7** The results of the measurement shall be presented graphically as a function of the fundamental frequency. The distortion values shall be expressed in dB when a gliding tone method is used. When applying a step-by-step method, the expression as a percentage shall be used.

Together with the results, the following information shall be given:

- the input voltage and the sound pressure level referred to 1 m;
- whether a gliding tone or a step-by-step method has been used;
- any discrete frequencies used; the distance of the measuring microphone from the reference point if this differs from 1 m and the conditions of measurement (free-field or half-space free-field).

### **24.1.3 Method of measurement for input voltages higher than the rated sinusoidal voltage**

**24.1.3.1** The loudspeaker shall be brought under free-field conditions for loudspeaker systems and in half-space free-field conditions for loudspeaker drive units. A series of tone burst input voltages with increasing frequencies shall be supplied to the loudspeaker. Each tone burst shall be long enough for the steady-state response to be achieved. Its amplitude shall be chosen to be not larger than the short-term maximum input voltage in accordance with 17.2.

NOTE The frequencies should be produced by a step-by-step method.

**24.1.3.2** A measuring microphone shall be situated at 1 m distance from the reference point, unless otherwise specified.

**24.1.3.3** A sampling-processing system shall be used to sample the tone burst response received by the measuring microphone. The sampling frequency shall be high enough to enable the highest harmonic of interest. To eliminate zero-crossing errors, either the sampling instants shall be coincident with the zero-crossings of the tone burst signal, or the microphone signals shall be windowed (a Hanning window is usually suitable). The system shall calculate the spectrum from the data of one or more cycles in order to obtain total sound pressure including fundamental  $p_t$  and the separate harmonics  $p_{nf}$ .

**24.1.3.4** The total harmonic distortion at input voltages higher than the rated sinusoidal voltage shall then be determined by the formula given in 24.1.2.6.

**24.1.3.5** The harmonic distortion components of the second and third orders at input voltages higher than the rated sinusoidal input voltage shall be determined by the formulas given in 24.2.2.6.

**24.1.3.6** The following data shall be given with the results of the measurement:

- the input voltage and the sound pressure level referred to 1 m;
- discrete frequencies at which measurements were made;
- distance of the measuring microphone to the reference point if this differs from 1 m;
- conditions of measurement (free-field or half-space free-field).

## **24.2 Harmonic distortion of the $n^{\text{th}}$ order (where $n = 2$ or $n = 3$ )**

### **24.2.1 Characteristic to be specified**

The harmonic distortion of the  $n^{\text{th}}$  order shall be specified, expressed in terms of total sound pressure  $p_t$ .



## 24.2.2 Method of measurement for input voltages up to the rated sinusoidal voltage

**24.2.2.1** The loudspeaker shall be brought under free-field conditions for loudspeaker systems and in half-space free-field conditions for loudspeaker drive units.

A series of sinusoidal input voltages with increasing frequencies, to 5 000 Hz, shall be supplied to the loudspeaker. The input voltages chosen shall be the most relevant for the intended use and should include but not exceed the rated sinusoidal voltage in accordance with 17.4.

NOTE The range of frequencies should be covered by means of gliding tones, because a step-by-step method may cause important information to be missed.

**24.2.2.2** A measuring microphone shall be situated 1 m from the reference point, unless otherwise specified.

**24.2.2.3** A selective voltmeter, such as a wave analyser, preceded, if necessary, by a high-pass filter that suppresses the fundamental, shall be connected to the measuring microphone.

**24.2.2.4** The sound pressure of the separate harmonics  $p_{nf}$  shall be measured.

**24.2.2.5** The total sound pressure, including the fundamental  $p_t$ , shall be measured by a wide band meter connected to the microphone.

**24.2.2.6** The harmonic distortion of the second order shall be determined by the formula:

in %: 
$$d_2 = \frac{p_{2f}}{p_t} \times 100 \%$$

in dB: 
$$L_{d2} = 20 \lg \left( \frac{d_2}{100} \right)$$

The harmonic distortion of the third order shall be determined by the formula:

in %: 
$$d_3 = \frac{p_{3f}}{p_t} \times 100 \%$$

in dB: 
$$L_{d3} = 20 \lg \left( \frac{d_3}{100} \right)$$

**24.2.2.7** The results of the measurement shall be presented graphically as a function of the fundamental frequency. The distortion values shall be expressed in dB when a gliding tone method is used. When applying a step-by-step method the expression as a percentage shall be used.

Together with the results, the following information shall be given:

- the input voltage and the sound pressure level referred to 1 m;
- whether a gliding tone or a step-by-step method has been used;
- any discrete frequencies used; the distance of the measuring microphone from the reference point if this differs from 1 m and the conditions of measurement (free-field or half-space free-field).

## 24.3 Characteristic harmonic distortion

### 24.3.1 Characteristic to be specified

The characteristic harmonic distortion shall be specified expressed in terms of the mean sound pressure in a stated frequency band.

### 24.3.2 Method of measurement

The measurement shall be in accordance with 24.1.2 except that the total sound pressure  $p_t$  shall be replaced by the mean sound pressure  $p_m$  determined in accordance with 20.5.2. The mean sound pressure shall apply to the loudspeaker a 1/3 octave band filtered pink-noise signal, wherein the signal power in each 1/3 octave shall be equal to the measuring signal power being used for measurement of harmonic total distortion as in 24.1.2

## 24.4 Modulation distortion of the $n^{\text{th}}$ order (where $n = 2$ or $n = 3$ )

### 24.4.1 Characteristic to be specified

The modulation distortion of the  $n^{\text{th}}$  order shall be specified as the ratio of the arithmetic sum of the r.m.s. values of the sound pressures due to distortion components at frequencies  $f_2 \pm (n-1) f_1$ , to the r.m.s. value of the sound pressure  $P_{f_2}$  due to the signal  $f_2$ .

$f_1$  and  $f_2$  are the frequencies of two input signals, whose ratio of the amplitudes shall be specified with  $f_1$  being lower in frequency than  $f_2$ .

### 24.4.2 Method of measurement

**24.4.2.1** The loudspeaker shall be brought under free-field or half-space free-field conditions. Two sources of sinusoidal signals with an amplitude ratio of 4:1 and with frequencies  $f_1$  and  $f_2$  ( $f_1 < f_2/8$ ) shall be connected to the input of an amplifier, and the output signal, being a linear superposition of  $f_1$  and  $f_2$ , connected to the loudspeaker.

NOTE The method of measurement for the two signals to the amplifier should be applied in accordance with IEC 60268-3.

**24.4.2.2** A measuring microphone shall be situated 1 m from the reference point, unless otherwise specified.

**24.4.2.3** A wave analyser shall be connected to the measuring microphone. Distortion components measured can be due both to modulation distortion and to Doppler effect; in order to separate the two kinds of distortion, phase measurements shall be required. Modulation components of frequencies  $f_2 \pm f_1$  and  $f_2 \pm 2f_1$  only shall be considered.

NOTE Measurements of higher order components have generally not been found valuable.

**24.4.2.4** The modulation distortion of the second order shall be determined by the formula:

in %: 
$$d_2 = \frac{P(f_2 - f_1) + P(f_2 + f_1)}{P_{f_2}} \times 100 \%$$

in dB: 
$$L_{d2} = 20 \lg \left( \frac{d_2}{100} \right)$$

The modulation distortion of the third order shall be determined by the formula:

$$\text{in \%:} \quad d_3 = \frac{P(f_2-2f_1) + P(f_2+2f_1)}{P_{f_2}} \times 100 \%$$

$$\text{in dB:} \quad L_{d3} = 20 \lg \left( \frac{d_3}{100} \right)$$

**24.4.2.5** The results of the measurement shall be presented graphically, as a function of a reference voltage which is the r.m.s. value of a sinusoidal voltage having the same peak-to-peak value as the test signal applied to the loudspeaker terminals. The conditions of measurement (free-field or half-space free-field), the frequencies  $f_1$  and  $f_2$  and their amplitude ratio shall be stated with the results.

## **24.5 Characteristic modulation distortion of the $n^{\text{th}}$ order (where $n = 2$ or $n = 3$ )**

### **24.5.1 Characteristic to be specified**

The modulation distortion of the  $n^{\text{th}}$  order shall be specified, expressed in terms of the sound pressure in a stated frequency band, excluding frequency  $f_1$ .

### **24.5.2 Method of measurement**

The measurement shall be made in accordance with 24.4.2 except that the total sound pressure  $p_{f_2}$  shall be replaced by the sound pressure in a stated frequency band, excluding frequency  $f_1$  in accordance with 20.1.

## **24.6 Difference frequency distortion (of the second order only)**

### **24.6.1 Characteristic to be specified**

The ratio of sound pressure radiated by the loudspeaker under test at frequency  $(f_2 - f_1)$ , and the total sound pressure radiated by the loudspeaker shall be specified. The frequencies  $f_1$  and  $f_2$  are two sinusoidal input signals of equal amplitudes, expressed in terms of r.m.s. value.

### **24.6.2 Method of measurement**

**24.6.2.1** The loudspeaker shall be brought under free-field or half-space free-field conditions. Two sources of sinusoidal signals with equal amplitudes and with frequencies  $f_1$  and  $f_2$  (usually  $f_2 - f_1 = 80$  Hz) shall be connected to the input of an amplifier and the output signal, being a linear superposition of  $f_1$  and  $f_2$ , connected to the loudspeaker.

NOTE A recommended minimum value for  $f_1$  is twice the value of the difference frequency between  $f_1$  and  $f_2$ , provided that this is within the rated frequency range of the loudspeaker.

**24.6.2.2** A measuring microphone shall be situated at 1 m from the reference point, unless otherwise specified.

**24.6.2.3** A narrow band-pass filter adjusted for frequency  $(f_2 - f_1)$  shall be connected to the measuring microphone, and the r.m.s. value of the component with frequency  $(f_2 - f_1)$  shall be measured.

**24.6.2.4** The second order difference frequency distortion shall be determined by the formula:

in %:

$$d = \frac{P_{(f_2-f_1)}}{P_{f_1} + P_{f_2}} \times 100 \%$$

where  $P_f$  is the sound pressure at frequency  $f$ ;

in dB:

$$L_d = 20 \lg \left( \frac{d}{100} \right)$$

**24.6.2.5** The results of the measurement shall be presented graphically, as a function of a measuring voltage and frequency:

$$\frac{f_1 + f_2}{2}$$

The conditions of measurement (free-field or half space free-field) shall be stated with the results.

## 25 Rated ambient conditions

### 25.1 Temperature ranges

#### 25.1.1 Performance limited temperature range – characteristic to be specified

The temperature range over which the variation of the characteristics of the loudspeaker will not exceed the specified tolerances shall be specified.

#### 25.1.2 Damage limited temperature range – characteristic to be specified

The range of environmental temperature during operation or storage shall be specified that, if exceeded, may result in permanent changes in the operating characteristics.

### 25.2 Humidity ranges

#### 25.2.1 Relative humidity range – characteristic to be specified

The relative humidity range over which the variation of the characteristics of the loudspeaker will not exceed the specified tolerances shall be specified.

#### 25.2.2 Damage limited humidity range – characteristic to be specified

The range of environmental relative humidity during operation or storage shall be specified that, if exceeded, may result in permanent changes in the operating characteristics.

## 26 Stray magnetic fields

**NOTE** It is sometimes necessary to know the value of the magnetic field generated by the loudspeaker in order to prevent interference with other nearby components, such as television and video components, computer devices, aircraft on-board instrumentation, etc.

## 26.1 Static components

### 26.1.1 Characteristic to be specified

The maximum value of the static magnetic field strength, in A/m, produced by the magnet system of the loudspeaker at 30 mm from any part (or associated parts) of its rear side, or from any part of its enclosure, when no audio signal is applied shall be specified.

If the static component ( $H$ ) is measured as the magnetic induction; the measured value shall be converted into ampere per metre using the following relations:

$$H = \frac{B}{\mu_0}$$

where

$\mu_0$  ( $= 4\pi \times 10^{-7}$  H/m) is the magnetic permeability of vacuum/air;

$B$  is the magnetic flux density, in T.

### 26.1.2 Method of measurement

**26.1.2.1** The static magnetic flux shall be measured using a Hall (or other suitable type) probe flux meter. A non-magnetic holder (for example wood or plastic) shall be fitted on to the probe to control the measuring distance from the loudspeaker under test, as shown in Figure 8.

**26.1.2.2** Before starting the measurement, the instrument shall be set to zero in accordance with the manufacturer's instructions in order to remove the influence of the Earth's magnetic field. To do this, the Hall probe fixture shown in Figure 8 shall be oriented and fixed to null the indication due to the Earth's magnetic field. Care shall be taken to exclude any magnetic material from the measuring area which exhibit a low and uniform ambient magnetic field.

**26.1.2.3** When the Hall probe is fixed, the loudspeaker under test shall be moved about the Hall probe holder to obtain the highest measured value. Measurement may also be made by changing the position and orientation of the Hall probe instead of changing that of the loudspeaker. If the positioning of the Hall probe is used, the measuring space shall not exhibit any external magnetic influence that exceeds one tenth of the magnetic field strength to be measured.

**26.1.2.4** The highest measured value of magnetic field strength, expressed in A/m, shall be recorded as the result.

NOTE The report should include the position and orientation for the maximum values with respect to the reference plane and the reference point of the loudspeaker. This information may be shown in a diagram.

## 26.2 Dynamic components

### 26.2.1 Characteristics to be specified

Maximum values shall be specified of both static and alternating components of the magnetic field strength, in A/m, created by the loudspeaker and associated parts at a measuring distance of 30 mm, when the loudspeaker is driven at its rated noise voltage of simulated programme signal in accordance with IEC 60268-1.

Both static and alternating components shall be specified. The rated noise voltage shall be stated with the results.

## 26.2.2 Method of measurement

**26.2.2.1** The loudspeaker to be tested shall be electrically driven by the simulated programme signal, in accordance with IEC 60268-1, at its rated noise voltage condition, in accordance with 17.1, during measurements.

**26.2.2.2** The static and alternating components shall be measured using a Hall probe flux meter (or other suitable type with measuring range up to 10 000 Hz), while alternating component measurement is possible with the standard search coil, in accordance with IEC 60268-1. A non-magnetic holder (for example wood or plastic) shall be fitted onto the probe to control the measuring distance from the loudspeaker under test as in 26.1.2.

**26.2.2.3** For a static component, the measuring procedure shall be the same as that described in 26.1.2.2.

**26.2.2.4** For an alternating component, before starting the measurement, the Hall probe (or search coil) fixture shall be oriented so that no external influence can reach one tenth of the alternating component to be measured, within the measuring frequency band.

NOTE Care should be taken to remove any electromagnetic influence from the measuring area that can compromise the required measuring accuracy.

**26.2.2.5** When the magnetic probe is properly oriented, the loudspeaker under test shall be applied against the magnetic probe holder, in any possible position and orientation, until the highest measured value is found. Measurement can also be made by changing the position and orientation of the Hall probe instead of changing that of the loudspeaker. In this case, the measuring area shall not exhibit any external magnetic influence that exceeds one tenth of the magnetic field strength to be measured.

**26.2.2.6** The highest measured values of the static component and of the alternating component of the magnetic field strength, expressed in A/m, shall be recorded as the results.

NOTE The report should include the position and orientation of the maximum values with respect to the reference plane and the reference point of the loudspeaker. This information may be shown in a diagram.

## 27 Physical characteristics

### 27.1 Dimensions

The outer frame and mounting dimensions of the loudspeaker shall be specified in accordance with IEC 60268-14 for preferred outer frame diameters and mounting dimensions of circular and elliptical loudspeakers.

### 27.2 Mass

The mass of the loudspeaker when ready for use shall be specified.

### 27.3 Cable assemblies

Cable connections and connectors shall be in accordance with either IEC 60268-11 or IEC 60268-12.

NOTE In some circumstances, the connectors which are at present standardized are unsuitable and the use of other types is unavoidable.

## 28 Design data

Further design data shall be specified as additional information such as:

- total air-gap flux;
- air-gap flux density;
- magnetic gap energy;
- d.c. resistance of the voice coil;
- number of turns of the voice coil;
- mass, material and type of magnet;
- length of the voice coil;
- height of the magnetic gap;
- maximum excursion  $X_{p-p}$ ;

## 29 Indication of the characteristics to be specified

Data that shall be given by the manufacturer are indicated in Table 1 by an “X”. Data that the manufacturer is recommended to give are indicated by the letter “R”.

A = data that shall be labelled on the loudspeaker (or on the rating plate);

B = data that shall be specified in a document available to the user before purchase of the loudspeaker;

Values given by the manufacturer should be stated as “rated...”.

**Table 1 – Indication of the characteristics to be specified**

Clauses and subclauses	Drive unit		System	
	A	B	A	B
13 Type description				
13.2 Loudspeaker drive units				
13.2.1 Principle of the transducer		X		
13.2.2 Type		X		
13.3 Loudspeaker system				X
14 Marking of terminals and controls	X		X	
15 Reference plane, reference point and reference axis				
15.1 Reference plane		X		X
15.2 Reference point		X		X
15.3 Reference axis		X		X
16 Impedance and derivative characteristics				
16.1 Rated impedance	X	X	X	X
16.2 Impedance curve		X		X
16.3 Total Q-factor ( $Q_t$ )		R		
16.4 Equivalent air volume of a loudspeaker drive unit compliance ( $V_{as}$ )		R		
17 Input voltage				
17.1 Rated noise voltage		X		X
17.2 Short-term maximum input voltage		R		R
17.3 Long-term maximum input voltage		X		X
17.4 Rated sinusoidal voltage		X		X
18 Input electrical power				
18.1 Rated noise power		X		X
18.2 Short-term maximum power		R		R
18.3 Long-term maximum power		X		X
18.4 Rated sinusoidal power		X		X
19 Frequency characteristics				
19.1 Rated frequency range		X		X
19.2 Resonance frequency		X		R
19.3 Tuning frequency of a bass reflex or passive radiator loudspeaker system				R
20 Sound pressure under free-field and half-space free-field conditions				
20.6 Mean sound pressure level in a stated frequency band		X		X
21 Response under free-field and half-space free-field conditions				
21.1 Frequency response		X		X
21.2 Effective frequency range		X		X
21.3 Transfer function		R		R
22 Output power (acoustic power)				
22.4 Mean efficiency in a frequency band		R		R
23 Directional characteristics				
23.1 Directional response pattern		R		R
23.2 Radiation angle		R		R
23.3 Directivity index		R		R
23.4 Coverage angle or angles		R		R
24 Amplitude non-linearity				
24.1 Total harmonic distortion (the rated value of the appropriate characteristic)		R		R
24.4 Modulation distortion of the $n^{\text{th}}$ order (where $n = 2$ or $n = 3$ )		R		R
24.6 Difference frequency distortion (of the second order only)		R		R
25 Rated ambient conditions				
25.1 Temperature range		R		R
25.2 Humidity ranges		R		R
26 Stray magnetic fields				
26.1 Static components		R		R
26.2 Dynamic components		R		R
27 Physical characteristics				
27.1 Dimensions		X		X
27.2 Mass		X		X
27.3 Cable assemblies		X		X
28 Design data		R		R



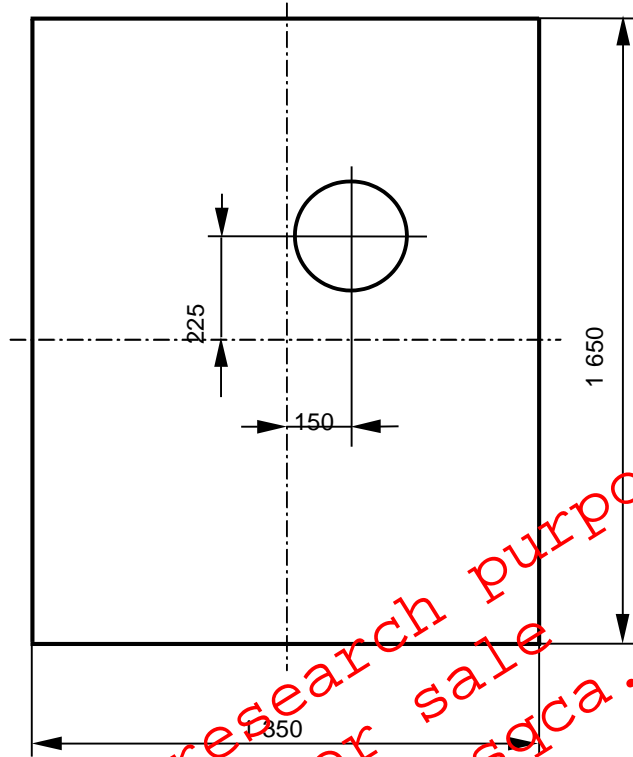

IEC 1264/03

Dimensions are in millimetres

Figure 2 - Standard baffle, dimensions

only for research purposes  
not for sale  
copyright www.psqca.com.pk

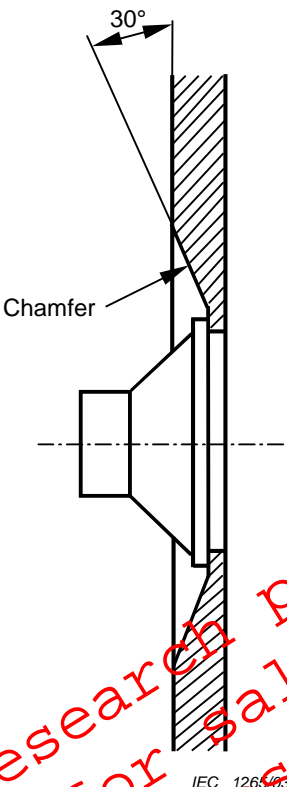

Figure 3 – Standard baffle with chamfer

only for research purposes  
not for sale  
copyright www.psqca.com.pk

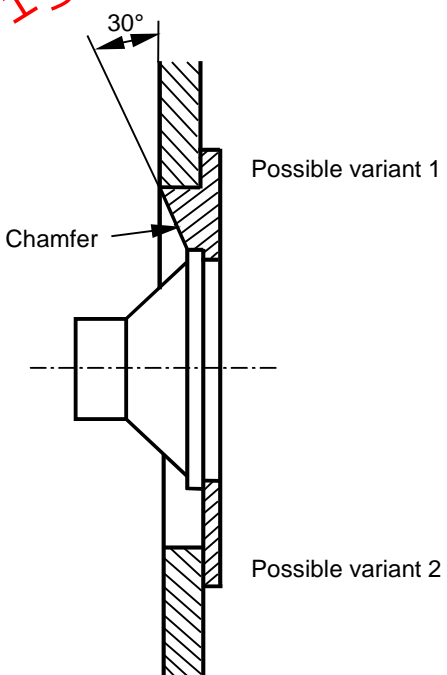
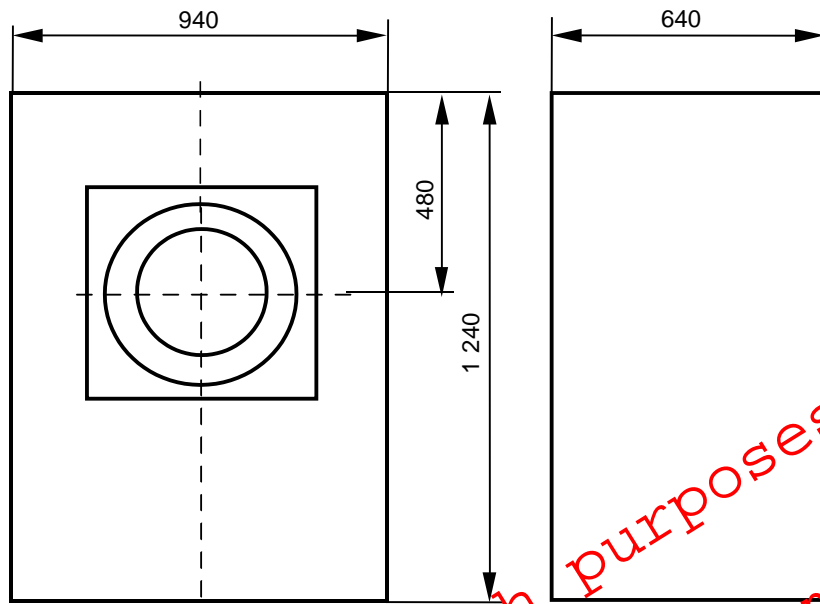

Figure 4 – Standard baffle with sub-baffle

IEC 1266/03



IEC 1267/03

(Net volume is about 600 l)

Dimensions are in millimetres

Figure 5 – Standard measuring enclosure type A

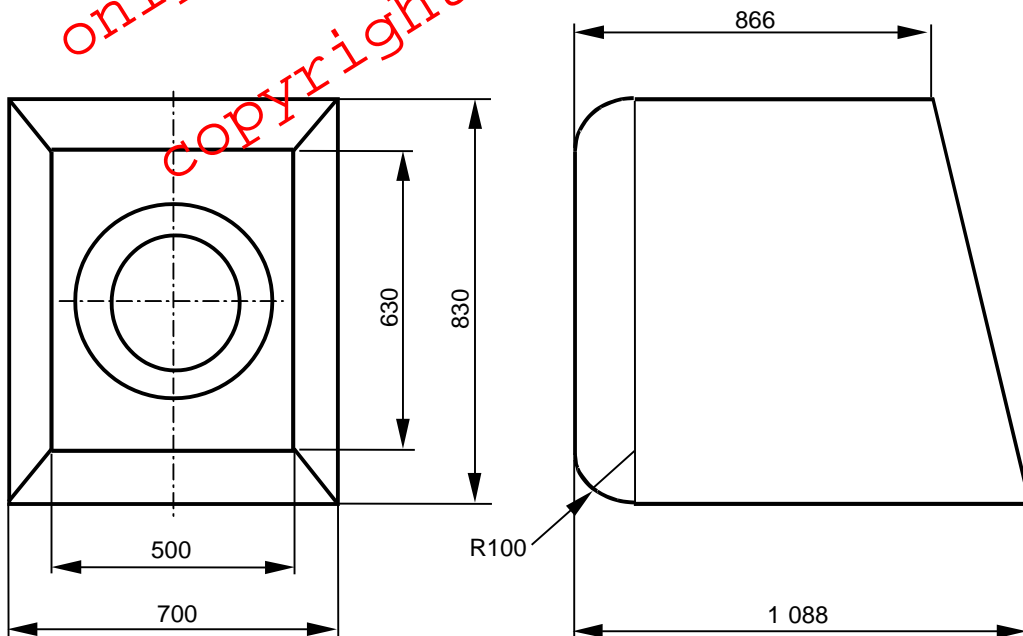

IEC 1268/03

(Net volume is about 450 l)

Dimensions are in millimetres

Figure 6 – Standard measuring enclosure type B

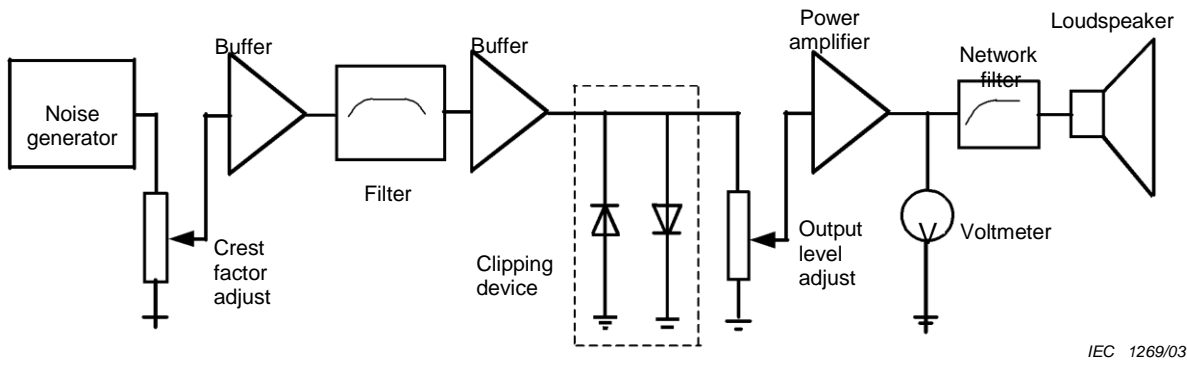

Figure 7 – Block diagram of test set-up

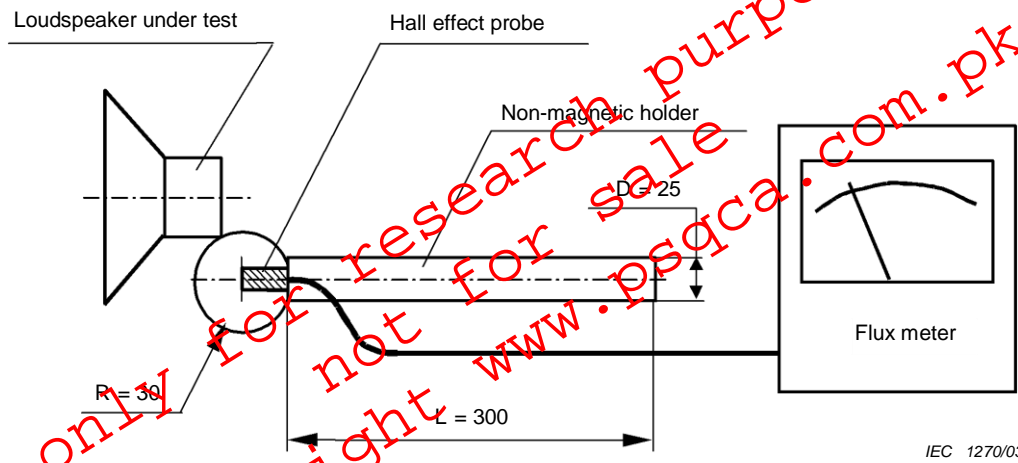

Figure 8 – Measuring apparatus for stray magnetic field

Dimensions are in millimetres

## Annex A (informative)

### Standard measuring enclosure type A

An example of standard measuring enclosure type A is shown in Figure A.1.

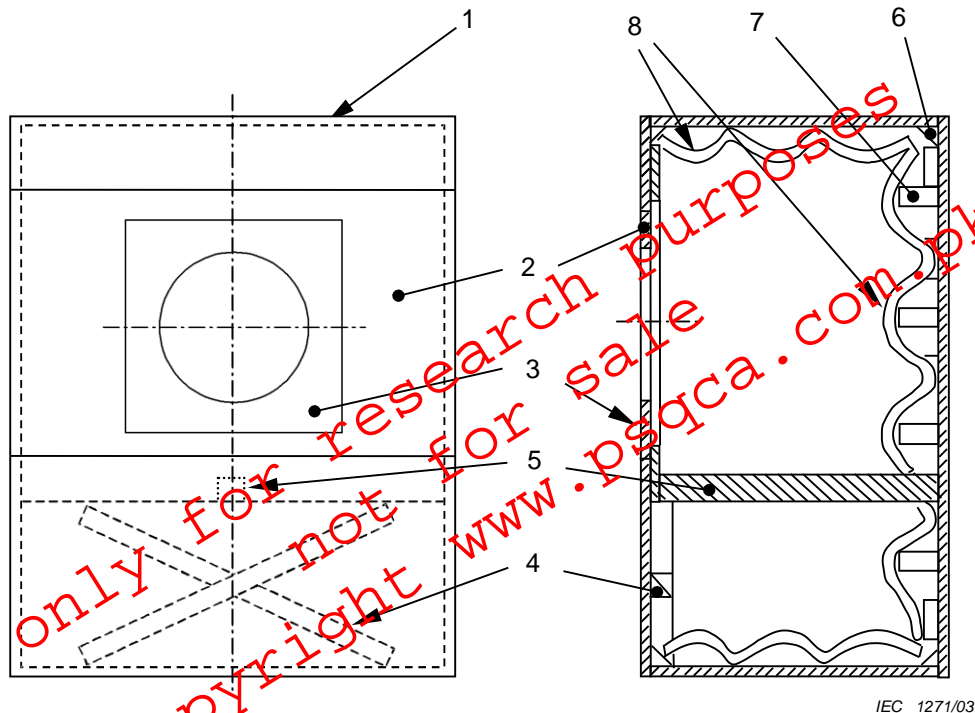

#### Components

- 1 Main body of enclosure (plywood: 21 mm thick or more, or equivalent)
- 2 Front baffle (plywood: 21 mm thick or more, or equivalent) (removable structure is allowed if necessary.)
- 3 Removable front panel (speaker fixture) (steel, 3 mm thick or more, or equivalent)
- 4 Front reinforcements
- 5 Brace reinforcements
- 6 Corner reinforcements
- 7 Rear reinforcements
- 8 Sound absorbing material (use glass wool of 50 mm thick and density of 20 kg/m<sup>3</sup> so that standing waves can be disregarded.)

NOTE Dimensions are shown in Figure 5.

**Figure A.1 – An example of standard measuring enclosure type A**

The correction curves for the diffraction effect of standard measuring enclosure type A, for a measuring distance of 1 m on the reference axis from free-field to half-space free-field, are shown in Figures A.2 and A.3.

NOTE Half-space free-field was approximated by an infinite (10,07 m × 8,15 m) board.

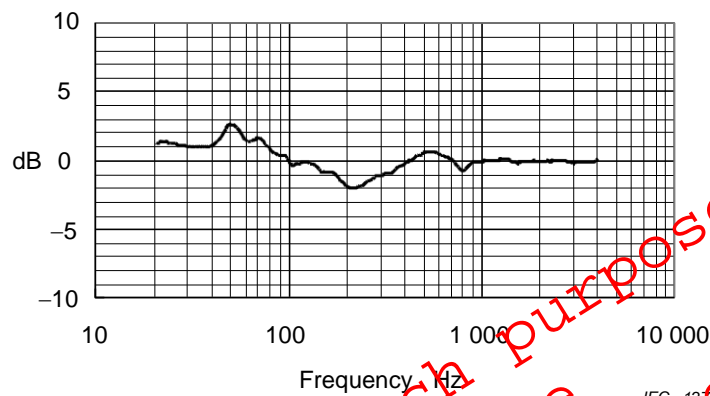

Figure A.2 – The correction curve for the diffraction effect of the standard measuring enclosure from free-field to half-space free-field (average of results, loudspeakers' diameter = 30 cm, 38 cm, 46 cm)

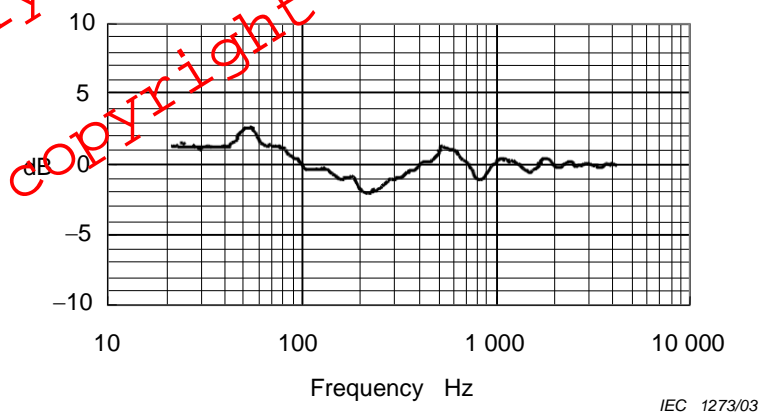
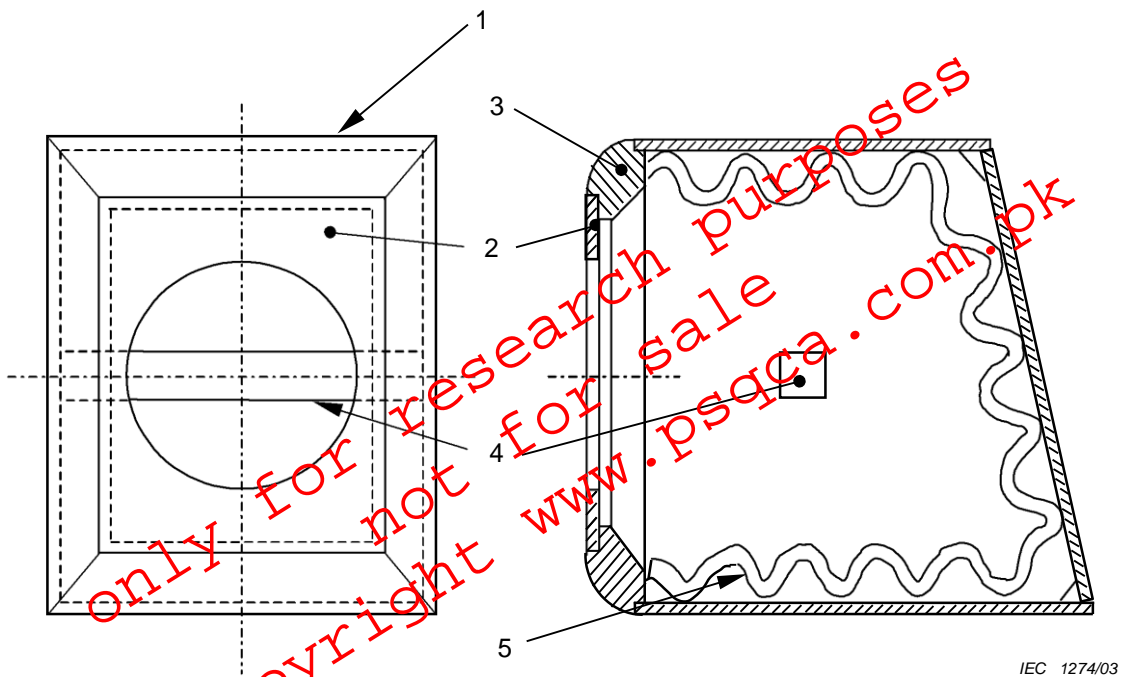

Figure A.3 – The correction curve for the diffraction effect of a standard measuring enclosure from free-field to half-space free-field (average of results, loudspeakers' diameter = 6 cm, 10 cm, 20 cm)

## Annex B (informative)

### Standard measuring enclosure type B

An example of standard measuring enclosure type B is shown in Figure B.1.



#### Components

- 1 Main body of enclosure (plywood: 25 mm thick or equivalent)
- 2 Removable front panel (speaker fixture: plywood or equivalent)
- 3 Front reinforcements
- 4 Brace reinforcements
- 5 Sound absorbing material (use glass wool of 50 mm thick and density of  $20 \text{ kg/m}^3$  so that standing waves can be disregarded.)

NOTE Dimensions are shown in Figure 6.

**Figure B.1 – An example of standard measuring enclosure type B**

Construction details and dimensions of scalable measuring enclosure type B are shown in Figure B.2 and Table B.1.

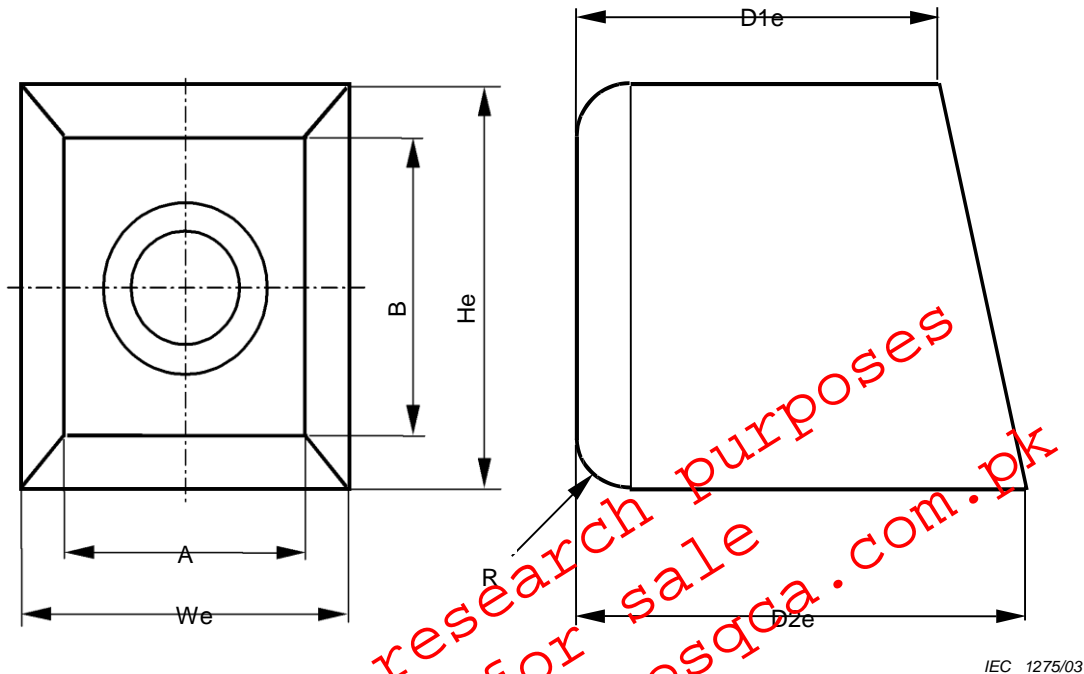

IEC 1275/03

**Key**

See Table B.1.

**Figure B.2 – Construction of scalable measuring enclosure type B****Table B.1 – Dimensions and ratios of scalable enclosure type B**

Enclosure dimensions		Symbol	Ratios
Width	internal	Wi	1
	external	We	NA
Height	internal	Hi	1,202
	external	He	NA
Depth 1	internal	D1i	1,274 <sup>a</sup>
	external	D1e	NA
Depth 2	internal	D2i	1,596 <sup>a</sup>
	external	D2e	NA
Radius		R	100 mm
Panel thickness			> 24 mm ( $V_n^b \geq 100$ ) > 18 mm ( $V_n^b < 100$ )
Side panel bracing			1x or 2x
NOTE Symbol "i" means internal and "e" means external measurement. NA means 'not applicable' – the dimension is controlled by other specified dimensions.			
<sup>a</sup> The average depth ratio $D_i = 1,435$ and the back panel tilt angle $\alpha = 15^\circ$ .			
<sup>b</sup> $V_n$ is the net volume in litres of the measuring enclosure			



The correction curves for the diffraction effect of standard measuring enclosure type B, for a measuring distance of 1 m on the reference axis from free-field to half-space free-field, are shown in Figures B.3 and B.4.

NOTE Half-space free-field was approximate by infinite (10,07 m  $\times$  8,15 m) board.

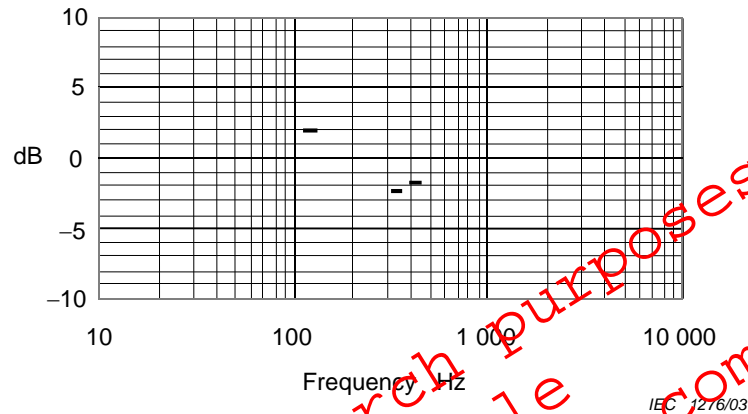

Figure B.3 – The correction curve for the diffraction effect of the standard measuring enclosure from free-field to half-space free-field (average of results, loudspeaker diameter = 30 cm, 38 cm, 46 cm)

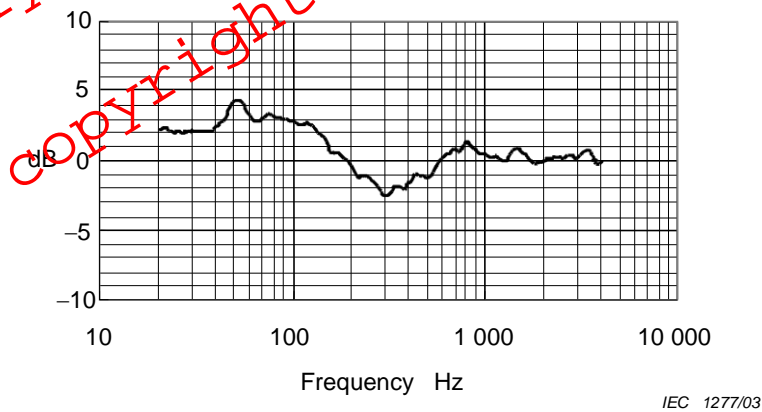

Figure B.4 – The correction curve for the diffraction effect of the standard measuring enclosure from free-field to half-space free-field (average of results, loudspeaker diameter = 6 cm, 10 cm, 20 cm)

## Annex C (informative)

### Definitions of terms used in Clause 13

The terms and definitions listed below relate to loudspeaker technologies. They are the most up-to-date ones and do not conflict with those listed in the IECV (IEC 60050).

#### C.1 Principle of the transducer

##### C.1.1

##### **electrodynamic (moving-coil) loudspeaker**

loudspeaker, the diaphragm of which is driven by a mechanical force that occurs when current flows through an electric conductor placed in a magnetic field

##### C.1.2

##### **electrostatic (condenser) loudspeaker**

loudspeaker, the diaphragm of which is driven by an electrostatic force

##### C.1.3

##### **piezoelectric (crystal) loudspeaker**

loudspeaker, the diaphragm of which is driven by a force of piezoelectric effect

##### C.1.4

##### **electromagnetic (moving-iron) loudspeaker**

loudspeaker, the diaphragm of which is driven by a magnetic force applied to a movable part of a ferromagnetic substance

#### C.2 Type

##### C.2.1

##### **direct radiator loudspeaker**

loudspeaker that directly radiates an acoustic sound from the diaphragm

##### C.2.2

##### **horn loudspeaker**

loudspeaker to which an end of a horn, the cross-sectional area of which changes continuously, is attached at the front of the diaphragm, so that the other end of the horn radiates an acoustic sound

##### C.2.3

##### **compression driver**

loudspeaker drive unit, of which the opening area to be connected to the horn is made smaller than the diaphragm area

#### C.3 Loudspeaker system

##### C.3.1

##### **baffle**

septum that is used to make acoustic separation between the front and the back of the diaphragm

**C.3.2  
enclosure**

box that isolates the acoustic sound radiated from the back of the diaphragm

**C.3.3  
bass reflex (vented) enclosure**

enclosure, the frequency response of which can be extended to a lower frequency than the resonant frequency of the loudspeaker, by installing an acoustic duct or diaphragm in the wall of the enclosure

**C.3.4  
horn**

pipe-like acoustic matching unit, the cross-sectional area of which changes continuously from one end to the other, used for acoustic impedance matching, and also for directivity adjustment

**C.3.5  
column (line) loudspeaker system**

loudspeaker system in which multiple loudspeakers are arranged in line

**C.3.6  
coaxial loudspeaker system**

loudspeaker system in which multiple loudspeakers are coaxially arranged

only for research purposes  
not for sale  
copyright www.psqca.com.pk

## Annex D (informative)

### Listening tests

#### D.1 Listening test for normal operation

Confirm normal operation by applying a programme signal to the loudspeaker to be tested.

- a) Install the loudspeaker as described in Clause 10.
- b) Apply the programme signal with maximum r.m.s. voltage equal to the rated noise voltage of the loudspeaker.
- c) Check the sound level, tone quality, noise, and presence of other defects.

NOTE 1 The programme signal is a speech or music signal of normal spectral distribution.

NOTE 2 This test is conducted mainly during the manufacturing process and reporting of the result is not required.

#### D.2 Listening test for mechanical noise (rattles)

This test checks for rub and buzz by listening to ascertain that the loudspeaker works normally when applying the rated sinusoidal voltage to the loudspeaker terminals.

- a) Mount the loudspeaker as specified in Clause 10.
- b) Check the sound of the loudspeaker by applying the rated sinusoidal voltage to the loudspeaker, changing the frequency of the sinusoidal signal, within the rated frequency range. The measuring voltage may be set freely by the manufacturer if necessary.
- c) The listening position should be a position where any abnormal sound is easily heard, at a distance of more than 0.3 m from the reference point of the loudspeaker, unless otherwise stated.
- d) Check the sound level, sound quality, noise level and the existence of other abnormal sound
- e) The power amplifier should have an output impedance smaller than one-third of the rated impedance of the loudspeaker and be able to provide a sinusoidal voltage at least twice the rated sinusoidal voltage of the loudspeaker. The total harmonic distortion shall not exceed 1 % at the loudspeaker terminals.

NOTE This test is conducted mainly during the manufacturing process and reporting of the result is not required.

## Bibliography

ISO 3743-1, *Acoustics – Determination of sound power levels of noise sources – Engineering methods for small, movable sources in reverberant fields – Part 1: Comparison method for hard-walled test rooms*

ISO 3743-2, *Acoustics – Determination of sound power levels of noise sources using sound pressure – Engineering methods for small, movable sources in reverberant fields – Part 2: Methods for special reverberation test rooms*

AES-5id-1997,1998: *Information document for room acoustics and sound reinforcement systems – Loudspeaker modelling and measurement – Frequency and angular resolution for measuring, presenting and predicting loudspeaker polar data*

-----

only for research purposes  
not for sale  
copyright [www.psqca.com.pk](http://www.psqca.com.pk)