

PAKISTAN STANDARD

PLUGS AND SOCKET-OUTLETS FOR HOUSEHOLD AND SIMILAR PURPOSES –

PART 2-5: PARTICULAR REQUIREMENTS FOR ADAPTORS



All Rights Reserved)

**PAKISTAN STANDARDS AND QUALITY CONTROL AUTHORITY,
STANDARDS DEVELOPMENT CENTRE,
PSQCA Complex Street 7 A Block –3
Scheme –36 Gulistan –e- johar Karachi**

**PLUGS AND SOCKET-OUTLETS FOR HOUSEHOLD AND SIMILAR
PURPOSES - PART 2-5: PARTICULAR REQUIREMENTS FOR ADAPTORS**

0. FOREWORD

- 0.1 This Pakistan Standard was adopted by the authority of the Board of Directors for Pakistan Standards and Quality Control Authority after approval by the Technical Committee for “Plugs and socket-outlets for household and similar purposes - Part 2-5: Particular requirements for adaptors” had been approved and endorsed by the Electrotechnical National Standards Committee on _____.
- 0.2 This Pakistan Standard was adopted on the basis of IEC 60884-2-5 since IEC Standard have been established in 2007, hence it is deemed necessary to adopt the International standard to keep abreast with the latest technology and as per with IEC standard.
- 0.3 This Pakistan Standard is an adoption of IEC: 60884-2-5 “ Plugs and socket-outlets for household and similar purposes Part 2-5: Particular requirements for adaptors” and its use hereby acknowledged with thanks.
- 0.4 This standard is subject to periodical review in order to keep pace with the development in industry. Any suggestions for improvement shall be recorded and placed before the revising committee in due course.
- 0.5 This standard is intended chiefly to cover the technical provisions relating to this standard and it does not include all the necessary provisions of a Contract.

CONTENTS

FOREWORD.....	
1 Scope.....	
2 Normative references	
3 Definitions	
4 General requirements	
5 General remarks on tests	
6 Ratings.....	
7 Classification.....	
8 Marking	
9 Checking of dimensions.....	
10 Protection against electric shock	
11 Provision for earthing	
12 Terminals and terminations	
13 Construction of fixed socket-outlets	
14 Construction of adaptors.....	
15 Interlocked socket-outlet parts of adaptors	
16 Resistance to ageing, protection provided by enclosures, and resistance to humidity.....	
17 Insulation resistance and electric strength	
18 Operation of earthing contacts.....	
19 Temperature rise	
20 Breaking capacity.....	
21 Normal operation.....	
22 Force necessary to withdraw the plug.....	
23 Flexible cables and their connection	
24 Mechanical strength	
25 Resistance to heat.....	
26 Screws, current-carrying parts and connections.....	
27 Creepage distances, clearances and distances through sealing compound.....	
28 Resistance of insulating material to abnormal heat, to fire and to tracking	
29 Resistance to rusting	
30 Additional tests on pins provided with insulating sleeves	
Annex A (normative) Safety-related routine tests for factory-wired portable accessories (protection against electric shock and correct polarity)	
Annex B (normative) Survey of specimens needed for tests	
Annex C (informative) Alternative gripping tests.....	
Annex D (normative) Switches incorporated in adaptors	
Annex E (informative) Changes planned for the future in order to align IEC 60884-1 with the requirements of IEC 60228, IEC 60998 and IEC 60999	
Annex AA (normative) Travel adaptors.....	
Annex BB (informative) Examples of adaptors	
Bibliography.....	

Figure AA.1 – World plug types.....

Table 101 – Nominal cross-sectional areas of flexible copper conductors for the temperature-rise test.....

Table 16 – Maximum and minimum withdrawal force for plug and socket-outlet parts of adaptors

not for sale www.psqca.com.pk

PLUGS AND SOCKET-OUTLETS FOR HOUSEHOLD AND SIMILAR PURPOSES –

Part 2-5: Particular requirements for adaptors

1 Scope

Replacement:

This part of IEC 60884 applies to adaptors for a.c. only with or without earthing contact, with a rated voltage greater than 50 V but not exceeding 440 V and a rated current not exceeding 32 A, intended for household and similar purposes, either indoors or outdoors.

This document also applies to travel adaptors (see Annex AA). For travel adaptors the scope is limited to a voltage rating greater than 50 V but not exceeding 250 V and to a current rating not exceeding 20 A.

Travel adaptors allowing the simultaneous connection of two or more plugs are not covered by this document.

NOTE 1 In the following countries the use of non-shuttered adaptors is not allowed: BE, CN, DK, ES, FR, IT, NO, MY, PT, SE, SG, UK, ZA.

NOTE 2 In the following countries adaptors having IP classes below IPX4 shall be provided with shutters: FI.

NOTE 3 In the following countries fused adaptors are not allowed: ZA.

NOTE 4 In the following countries rewirable external flexible cables connected to adaptors are not allowed: ZA.

NOTE 5 In the following countries, travel adaptors shall not be used for charging electrical vehicles: CH, SE.

This document covers the requirements for adaptors with additional functions, however the additional function itself is not covered by this standard.

NOTE 6 Examples of additional functions are electronic power supply units, dimmers, timers, protection devices, infrared switches.

This document does not apply to adaptors incorporating connectors according to IEC 60320 (all parts).

Adaptors complying with this document are suitable for use at ambient temperatures not normally exceeding +40 °C, but their average over a period of 24 h does not exceed +35 °C, with a lower limit of the ambient air temperature of –5 °C.

NOTE 7 Tests for temperatures below normal range are under consideration.

2 Normative references

This clause of Part 1 is applicable except as follows:

Addition:

IEC 60127-2, *Miniature fuses – Part 2: Cartridge fuse-links*

IEC 60127-3, *Miniature fuses – Part 3: Sub-miniature fuse-links*

IEC 60269-3, *Low-voltage fuses – Part 3: Supplementary requirements for fuses for use by unskilled persons (fuses mainly for household or similar applications) – Examples of standardized systems of fuses A to F*

IEC 60884-1:2002, *Plugs and socket-outlets for household and similar purposes – Part 1: General requirements*

IEC 60884-1:2002/AMD1:2006

IEC 60884-1:2002/AMD 2:2013

3 Definitions

This clause of Part 1 is applicable except as follows:

Replacement of NOTE 3:

NOTE 3 The term "accessory" is used as a general term covering plugs, socket-outlets and adaptors; the term "portable accessory" covers plugs, portable socket-outlets and adaptors.

Addition:

NOTE 101 The term "adaptor" is used as a general term covering all types of adaptors except where reference is made to one particular type.

3.25 Replacement:

rated voltage

value of voltage assigned to the accessory by the manufacturer

3.26 Replacement:

rated current

value of current assigned to the accessory by the manufacturer

Addition:

3.101

adaptor

portable accessory constructed as an integral unit incorporating one plug part and one or more socket-outlet parts, with or without integrated additional functions, allowing the connection of one or more plugs to a socket-outlet, both the socket-outlet and the plugs belonging to the same national system

Note 1 to entry: Examples of national systems are listed in IEC TR 60083.

3.102

fused adaptor

adaptor incorporating a replaceable fuse link in one or more current-carrying poles

Note 1 to entry: Fuses of fused adaptors are not intended to protect appliances or parts of them against overload.

3.103

polarized adaptor

adaptor constructed so that, when inserted in a socket-outlet installed in a polarized wiring installation, the correct relationship between the neutral and the line pole or poles is maintained

3.104

single-way adaptor

adaptor with one socket-outlet part allowing the connection of one plug

3.105**multi-way adaptor**

adaptor with more than one socket-outlet part allowing the simultaneous connection of two or more plugs

3.106**travel adaptor**

portable accessory, intended for temporary use, allowing the connection of one or more plug type(s) of different national systems to a socket-outlet that is not designed to accept such plugs

Note 1 to entry: A travel adaptor is not necessarily an integral unit and it can include integrated additional functions.

Note 2 to entry: Examples of national systems are listed in IEC TR 60083.

3.107**travel adaptor with movable pins**

travel adaptor where plug pins may slide in and out, rotate or fold in any direction, so that they are not permanently fixed but have means to be locked in position for normal use

3.108**intermediate adaptor**

adaptor allowing the connection of one or more plugs to a socket-outlet via a control device such as a dimmer, photo-electric switch, etc., which is connected to the adaptor by an external flexible cable

3.109**rewirable intermediate adaptor**

intermediate adaptor constructed in such a way that the external flexible cable can be replaced

3.110**non-rewirable intermediate adaptor**

intermediate adaptor constructed in such a way that it forms a complete unit with the external flexible cable after connection and assembly by the manufacturer of the adaptor

Note 1 to entry: See also 14.1.

3.111**adaptor with cable outlet**

adaptor which may be rewirable or non-rewirable, and constructed in such a way that it allows the connection of an external flexible cable through a cable outlet

3.112**rated power**

power value assigned to the accessory by the manufacturer

4 General requirements

This clause of Part 1 is applicable.

5 General remarks on tests

This clause of Part 1 is applicable except as follows:

Addition:

For the purposes of the tests, unless otherwise specified, the word “adaptors” covers all adaptors including fused adaptors, polarized adaptors, single-way adaptors, multi-way adaptors, intermediate adaptors, adaptors with cable outlet and travel adaptors.

6 Ratings

This clause of Part 1 is applicable except as follows:

Addition:

6.101 The rated voltage of the adaptor shall not be lower than the nominal voltage of the supply system to which it can be connected via a socket-outlet.

NOTE Nominal voltages are defined in IEC 60038.

6.102 The rated current of the adaptor shall be the lowest value of the following:

- the rated current of the plug part; or
- the arithmetic sum of the highest rated currents of all plugs which can be simultaneously inserted into the adaptor; or
- the rated current of the incorporated overcurrent protective device, if any.

6.103 When assigned, the rated power of the adaptor shall be calculated by multiplying the rated current (as determined in 6.102) and the rated voltage (as determined in 6.101) at a power factor equal to 1.

Compliance with the requirements of 6.101 to 6.103 is checked by inspection of the marking.

7 Classification

This clause of Part 1 is applicable.

8 Marking

This clause of Part 1 is applicable except as follows:

8.1 *Replacement of the first dashed item:*

- rated current in amperes or rated power in watts, or both;

Addition at the end of the subclause:

The marking for the rated power, if any, shall be completed by the word MAX.

NOTE 101 These markings can be shown as in the examples: MAX 2 000 W or 2 000 W MAX.

The rated power and/or rated current marking shall be easily discernible until the last plug is connected.

NOTE 102 In the following country, marking of the rated power in watts, visible when the adaptor is in use, is mandatory: FR.

Fused adaptors shall be marked to indicate the presence of a fuse within the adaptor and this marking may be in the form of a symbol.

Fused adaptors shall be marked with the rated current and type of fuse on the fuse-holder or in the proximity of the fuse.

An instruction, which may be a symbol or a sentence, warning against inserting an adaptor into another adaptor shall be provided by the manufacturer:

- on the adaptor, or
- on the smallest package unit, or
- on the instruction sheet accompanying the adaptor.

NOTE 103 A standardized symbol and/or sentence can be defined by the National Committees.

8.2 Addition before NOTE 1:

Watts W

Fuse 
 (see IEC 60417-5016:2002-10)

9 Checking of dimensions

This clause of Part 1 is applicable.

10 Protection against electric shock

This clause of Part 1 is applicable except as follows:

10.1 Replacement of the second paragraph and NOTE:

Live parts shall not be accessible when the plug part of an adaptor is in partial or complete engagement with a socket-outlet of the same system.

NOTE In the following countries this requirement does not apply when the plug part of the adaptor is partially engaged: CA, DK, JP, US.

Replacement of the fifth paragraph:

For adaptors, the test finger is applied in every possible position when the adaptor is in partial or complete engagement with a socket-outlet of the same system.

10.3 Replacement of the first paragraph:

It shall not be possible to make contact between a pin of a plug and a live socket contact of an adaptor or between a pin of an adaptor and a live socket contact of a socket-outlet, of the same system, whilst any other current-carrying pin is accessible.

10.4 Replacement of the first paragraph:

External parts of plugs, with the exception of assembly screws and the like, current-carrying and earthing pins, earthing straps and metal rings around pins and accessible metal parts fulfilling the requirements of 10.2.1 or 10.2.2 of IEC 60884-1:2002, IEC 60884-1:2002/AMD1:2006 and IEC 60884-1:2002/AMD2:2013, shall be of insulating material.

10.5 Replacement of the first paragraph:

not for sale www.psqca.com.pk

Shuttered socket-outlet parts of adaptors shall, in addition, be constructed in such a way that live parts are not accessible without a plug in engagement, when checked with the gauges shown in Figures 9 and 10

Addition:

10.101 Removal of the fuse and/or fuse carrier shall not result in live parts becoming accessible when the adaptor is in full engagement with a socket-outlet.

Compliance is checked by inspection and, in case of doubt, by applying test probe 13 according to IEC 61032 with a force not exceeding 5 N when the fuse and/or fuse carrier are not in position as in normal use and with the adaptor in full engagement with a socket-outlet. The test probe shall not touch live parts.

11 Provision for earthing

This clause of Part 1 is applicable.

12 Terminals and terminations

This clause of Part 1 is applicable except as follows:

12.1.1 *Replacement of the second paragraph:*

Adaptors with a cable outlet and rewirable intermediate adaptors shall be provided with terminals with screw clamping.

13 Construction of fixed socket-outlets

This clause of Part 1 is not applicable.

14 Construction of plugs and portable socket-outlets

This clause of Part 1 is applicable except as follows:

Replacement of the title:

14 Construction of adaptors

14.1 *Replacement:*

Adaptors shall be constructed in such a way that they cannot be opened by hand or by using a general purpose tool, for example a screwdriver used as such, without making it permanently useless.

Exception is made for adaptors with a cable outlet and rewirable intermediate adaptors, where they shall be constructed in such a way that they can be opened using a general purpose tool, for example a screwdriver used as such.

Compliance is checked by inspection.

NOTE 1 An adaptor is considered permanently useless, when, while re-assembling the adaptor, parts or materials other than the original are used.

NOTE 2 In the following country multiway adaptors shall be so designed and constructed that it is not possible to create additional outputs when plugging two or more multiway adaptors into each other: BE.

NOTE 3 In the following country rewirable adaptors are not allowed: ZA.

14.2 Replacement of the first paragraph:

Pins of adaptors shall have adequate mechanical strength.

14.3 Replacement of the first and second paragraphs:

Pins of adaptors shall be:

- locked against rotation, except where rotation is not likely to impair safety or function;
- impossible to remove without dismantling the adaptor;
- adequately fixed in the body of the adaptor when the adaptor is wired and assembled as for normal use.

It shall not be possible to arrange the pins or contacts of adaptors in an incorrect position.

14.4 Replacement of the first paragraph:

Earthing contacts, phase contacts and neutral contacts of adaptors shall, when in use, be locked against rotation and removable only with the aid of a tool, after dismantling the adaptor.

14.11 Replacement of the first line of the first paragraph:

For adaptors with a cable outlet and rewirable intermediate adaptors:

14.13 Replacement:

If covers of adaptors are provided with bushes for entry holes for the pins, these bushes shall not become detached inadvertently from the inside when the cover is removed.

Compliance is checked by inspection.

14.15 Replacement of the first paragraph:

The engagement face of the plug part of adaptors shall have no projections other than the pins, when the adaptor is wired and assembled as for normal use.

14.16 Replacement of the first paragraph:

The socket-outlet parts of adaptors shall be designed in such a way that full engagement of associated plugs is not prevented by any projection from their engagement face.

14.23 Replacement:

Adaptors shall not impose undue strain on fixed socket-outlets.

Compliance is checked by the following test.

The adaptor is inserted into a fixed socket-outlet complying with Part 1.

Each socket-outlet part is first fitted with a relevant plug completed with 1 m of 0,75 mm² circular flexible cable of 60227 IEC 53 type.

The number of conductors shall be the same as that of the poles of the relevant plug.

The socket-outlet is pivoted about a horizontal axis through the axis of the live socket contacts at a distance of 8 mm behind the engagement face of the socket-outlet and parallel to this engagement face.

The additional torque which has to be applied to the socket-outlet in order to maintain the engagement face in the vertical plane shall not exceed 0,25 Nm.

During the test, care shall be taken that the flexible cable(s) hang(s) freely.

NOTE In the following countries a torque value of 0,5 Nm is allowed: CH, SE.

Addition:

14.23.101 Adaptors shall withstand the lateral strain imposed by equipment likely to be introduced into them.

Compliance is checked by the following test using the device shown in Figure 13.

The specimen is mounted on a vertical surface with, initially, the plane through the live socket contacts horizontal. The face to be tested shall be in a vertical position and parallel to the vertical mounting surface.

The device is then fully-engaged, and a force of 5 N is applied in a vertically downward direction.

The device is removed after 1 min and the adaptor is turned 90° on the mounting surface. The test is made four times, the adaptor being turned 90° after each engagement. During the test the device shall not come out. The test is repeated for each socket-outlet part of the adaptor.

After the test, the adaptor shall show no damage within the context of this document, in particular it shall comply with the requirements of Clause 22.

14.24 Replacement:

Adaptors shall be shaped in such a way and/or made of such a material that they can be easily withdrawn by hand from the relevant socket-outlet.

In addition, the gripping surfaces shall be designed in such a way that the adaptor can be withdrawn without having to pull the flexible cable, if any.

Compliance is checked by inspection and in case of doubt by test.

NOTE Examples of possible tests are given in Annex C and by replacing the word "plug" by "adaptor".

14.25 This subclause of Part 1 is not applicable.

Addition:

14.101 The plug part of adaptors shall be provided with earthing pins or contacts if any one of the socket-outlet parts is provided with an earthing pin or contact.

An adaptor allowing the connection between a socket-outlet with earthing contact and a plug without earthing contact for class zero equipment is not permitted.

Compliance is checked by inspection and by the test of 11.5.

14.102 Adaptors for use in polarized socket-outlets shall be designed in such a way that the internal connection shall ensure that plug pins, socket-contacts and terminals, if any, maintain the same polarity at the input and output parts of the adaptor.

Compliance is checked by inspection and if necessary by an electrical continuity test.

14.103 If the insulation of an external flexible cable is not equivalent at least to that of cables according to the relevant IEC standard, and it does not comply with the electric strength test carried out between the cable and a metallic sheet wrapped around the insulation according to the specifications of 17.2, the cable shall be considered as a bare conductor.

14.104 Provision shall be made within the body of a fused adaptor for suitable fuse-link complying with IEC 60269-3, IEC 60127-2 or IEC 60127-3 as far as they reasonably apply.

The fuse-link shall be connected between an adaptor plug pin and the corresponding socket contact(s).

In polarized systems the fuse-link shall be mounted between the line plug pin and the corresponding line socket contact(s).

Fuse-links shall not be fitted in the earthing circuit.

The design of the adaptor shall be such that the fuse-link cannot be left in inadequate contact when the adaptor is assembled.

Compliance is checked by inspection.

14.105 Adaptors having a plug part standardized with a rated current of 2,5 A shall be provided with an overcurrent protective device rated 2,5 A or less.

NOTE Examples of a plug part standardized with a rated current of 2,5 A are provided in EN 50075.

Compliance is checked by inspection.

14.106 Adaptors shall not have an enclosure that is shaped or decorated like a toy.

NOTE Examples of such enclosures are those representing animals, characters, persons or scale models.

Compliance is checked by inspection.

14.107 Adaptors shall not have any socket-outlet part which permits the insertion of a plug with a higher current rating than the rated current of the plug part of the adaptor, unless the adaptor is provided with an overcurrent protective device rated less than or equal to the rated current of the plug part.

NOTE In the following country different rules may apply: IT.

Compliance is checked by inspection.

15 Interlocked socket-outlets

This clause of Part 1 is applicable except as follows:

Replacement of the title:

15 Interlocked socket-outlet parts of adaptors

Replacement of the first paragraph:

Socket-outlet parts of adaptors interlocked with a switch shall be constructed in such a way that a plug cannot be inserted or completely withdrawn from the adaptor while the socket-contacts are live, and the socket-contacts of the adaptor cannot be made live until a plug is almost completely in engagement.

16 Resistance to ageing, protection provided by enclosures, and resistance to humidity

This clause of Part 1 is applicable except as follows:

16.1 Resistance to ageing

Replacement of the seventh, eighth and ninth paragraphs:

For adaptors, the plug of the same national system shall be inserted into each socket-outlet part during the test. A plug available in the market can be suitably modified if necessary to allow the closure of the lid, if any.

Within a national system, the plug which is deemed to give the most severe condition shall be used for the test where more than one plug type can be inserted in the socket-outlet part.

NOTE 101 The national systems are listed in IEC TR 60083.

For adaptors, after having withdrawn the test plug from the socket-outlet part, the contact pressure of the contact assembly is checked as specified in 22.2 with the single-pin gauge. The gauge shall not fall from the contact assembly within 30 s.

17 Insulation resistance and electric strength

This clause of Part 1 is applicable except as follows:

17.1.1 Replacement:

For adaptors the insulation resistance is measured consecutively:

- a) between all poles connected together and a metal foil in contact with the outer surface of accessible external parts of insulating material including external assembly screws, the measurements being made with plug(s) in engagement;
- b) between each pole in turn, and all others, these being connected together to a metal foil in contact with the outer surface of accessible external parts of insulating material including external assembly screws with plug(s) in engagement;
- c) for adaptors with cable outlet and rewirable intermediate adaptors, between any metal part of any cable anchorage, including clamping screws, and the earthing pin or terminal, if any;

- d) for adaptors with cable outlet and rewirable intermediate adaptors, between any metal part of the cable anchorage and a metal rod of the maximum diameter of the flexible cable inserted in its place (see Table 17).

Incorporated components connected in parallel to the line contacts shall be disconnected. For this test, if required, the specimens shall be prepared by the manufacturer.

While the metal foil is wrapped round the outer surface or placed in contact with the inner surface of parts of insulating material, it is pressed against holes or grooves without any appreciable force by means of test probe 11 of IEC 61032.

17.1.2 This subclause of Part 1 is not applicable.

18 Operation of earthing contacts

This clause of Part 1 is applicable.

19 Temperature rise

Replacement:

Adaptors shall be constructed in such a way that they comply with the following temperature rise test.

All adaptors are tested according to 19.101 and adaptors with incorporated components are additionally tested according to 19.102.

For the test of 19.101, if required, the specimens shall be prepared by the manufacturer.

19.101 *Adaptors shall be tested in a draught-free environment at the centre of a plane wooden sheet which shall be at least 20 mm thick, 500 mm wide and 500 mm high.*

Socket-outlet parts of adaptors are tested using a test plug with brass pins having the minimum specified dimensions.

Clamping units having the dimensions specified in Figure 44 are fitted on each live pin and earthing pin, if any, of the plug part of the adaptor. Each clamping unit is equipped with a thermocouple which can be mounted either together with the pin or fixed permanently within the dotted area of Figure 44.

If it is not possible to use the clamping unit of Figure 44 due to the design of the plug, the clamping unit may be modified in order to perform the test.

In this case the diameter of the screw, the threaded hole and the total volume of the modified clamping unit shall be identical to Figure 44.

The screw is then placed approximately in the middle of the bare part of the pin and tightened with a torque of 0,8 Nm.

An alternating current of the value specified below is then passed for $60 \begin{matrix} +5 \\ 0 \end{matrix}$ min.

Adaptors with a plug part having lateral earthing contacts or resilient earthing contacts are tested using a fixed socket-outlet complying with the relevant national standard and having as

near to-average characteristics as can be selected, but with minimum size of the earthing pin, if any.

In this latter case, the adaptor under test is inserted into the fixed socket-outlet and an alternating current of the value specified below is then passed for $60 \begin{matrix} +5 \\ 0 \end{matrix}$ min.

Adaptors with incorporated components are tested as follows:

- incorporated components connected in series to the line contacts are short circuited;
- incorporated components connected in parallel to the line contacts are disconnected.

Non-rewirable adaptors with a cable outlet and non-rewirable intermediate adaptors are tested with the cable supplied.

Adaptors with a cable outlet and rewirable intermediate adaptors are fitted with flexible polyvinyl chloride insulated conductors having a nominal cross-sectional area as shown in Table 101.

Adaptors with a cable outlet are tested as multi-way adaptors, considering the cable outlet as being a socket-outlet part.

Table 101 – Nominal cross-sectional areas of flexible copper conductors for the temperature-rise test

Rated current A	Nominal cross-sectional area mm ²
Up to and including 13	1
Over 13 and up to and including 16	1,5
Over 16	4

The terminal screws or nuts are tightened with a torque equal to two-thirds of that specified in 12.2.8.

To ensure normal cooling of the terminals, the conductors connected to them shall have a length of at least 1 m.

A test current shall be applied:

- a) through each separate socket-outlet part in turn,
 - 1) for adaptors without incorporated overcurrent protective device, the test current being as follows:
 - for $I_n \leq 10$ A, test current = $1,4 I_n$,
 - for $I_n > 10$ A, test current = $1,25 I_n$,
 where I_n is the rated current of the plug that can be inserted in the socket-outlet part;
 - 2) for adaptors with incorporated overcurrent protective device, the test current being the conventional tripping/fusing current of the incorporated overcurrent protective device after 1 h, but not higher than the value calculated in the first bullet;
- b) through all socket-outlet parts simultaneously, when the rated current of all the plugs that can be inserted in the socket-outlet parts are lower than the rated current of the plug part, dividing the total test current among the socket-outlet parts in proportion to the rated current of the plugs that can be inserted,

- 1) for multi-way adaptors without incorporated overcurrent protective device, the total test current being as follows:
 - for $I_n \leq 10$ A, test current = $1,4 I_n$,
 - for $I_n > 10$ A, test current = $1,25 I_n$,
 where I_n is the rated current of the adaptor;
- 2) for multi-way adaptors with incorporated overcurrent protective device, the total test current being the conventional tripping/fusing current of the incorporated overcurrent protective device after 1 h, but not higher than the value calculated in the first bullet.

In the case of non-rewirable adaptors care should be taken to minimize the influence on the structure/design/performance of the adaptor when accessing the terminations of the adaptor.

For adaptors having three poles or more, the current during the test shall be passed through the phase contacts, where applicable. In addition, separate tests shall be made passing the current through the neutral contact, if any, and the adjacent phase contact and through the earthing contact, if any, and the nearest phase contact. For the purpose of this test, earthing contacts, irrespective of their number, are considered as one pole.

The temperature rise of the terminals, terminations and clamping units according to Figure 44 determined by means of thermocouples shall not exceed 45 K.

For the purpose of the test of 25.3, the temperature rise of external parts of insulating material not necessary to retain current-carrying parts and parts of the earthing circuit in position, even though they are in contact with them, shall also be determined.

19.102 *In addition to the tests of 19.101, adaptors with incorporated components are tested as in 19.101 item a) but with the incorporated components not short circuited or disconnected and with a test current which is the lowest between the rated current of the incorporated overcurrent protective device, if any, and the rated current of the plugs that can be inserted. Incorporated components, other than the overcurrent protective devices, shall be operated during the test in the worst case conditions with regard to power dissipation. Where incorporated components need their rated voltage to operate, the test voltage shall be the rated voltage.*

For those tests, in addition to the verification of the temperature rise of the terminals, terminations and clamping units according to Figure 44, the maximum temperature rise of accessible metal parts shall be measured and shall not be higher than 30 K and of accessible non-metallic parts not higher than 40 K.

In the case of non-rewirable accessories care should be taken to minimize the influence on the structure/design/performance of the product when accessing the terminations of the product.

20 Breaking capacity

This clause of Part 1 is applicable except as follows:

Replacement of the second paragraph:

Compliance is checked by testing socket-outlet parts of adaptors and plug parts of adaptors with pins which are not solid, by means of an appropriate test apparatus, an example of which is shown in Figure 16.

Replacement of the fourth paragraph:

Socket-outlet parts of adaptors are tested using a test plug with brass pins having, if applicable, insulating sleeves, and having the maximum specified dimensions, with a tolerance of $\begin{matrix} 0 \\ -0,06 \end{matrix}$ mm and spaced at the nominal distance, with a tolerance of $\begin{matrix} +0,05 \\ 0 \end{matrix}$ mm. As far as the extremities of the sleeves are concerned, it is sufficient that their dimensions are within the tolerances given in the relevant standard sheet.

Replacement of the sixth paragraph:

Plug parts of adaptors are tested using fixed socket-outlets complying with Part 1 and having as near to average characteristics as can be selected.

Replacement of the eighth paragraph:

The plug part of the adaptor is inserted and withdrawn from the socket-outlet 50 times (100 strokes) at a rate of:

- 30 strokes per minute for adaptors having a rated current up to and including 16 A and a rated voltage up to and including 250 V;
- 15 strokes per minute for all other adaptors.

Replacement of the ninth paragraph:

The test voltage shall be 1,1 times the rated voltage and the test current shall be 1,25 times the rated current of the plug that can be inserted in the socket-outlet part.

Addition before the penultimate paragraph:

Each socket-outlet part and plug part of an adaptor shall be tested separately.

Adaptors with incorporated components are tested as follows:

- incorporated components connected in series to the live contacts are short circuited;
- incorporated components connected in parallel to the live contacts are disconnected.

21 Normal operation

This clause of Part 1 is applicable except as follows:

Replacement of the second paragraph:

Compliance is checked by testing the socket-outlet parts of adaptors and the plug part of adaptors with resilient earthing socket-contacts or with pins which are not solid, by means of an appropriate test apparatus, an example of which is shown in Figure 16.

Replacement of the paragraph before NOTE 3:

Plug parts of adaptors are tested using a fixed socket-outlet complying with Part 1 and having as near to average characteristics as can be selected.

Replacement of the two paragraphs after NOTE 3:

The specimens are tested at rated voltage, in a circuit with $\cos \varphi = 0,8 \pm 0,05$, with an alternating current as follows:

- for adaptors without incorporated overcurrent protective device, the test current being the rated current of the plug that can be inserted in the socket-outlet part;
- for adaptors with incorporated overcurrent protective device, the test current being the rated current of the incorporated overcurrent protective device, but not higher than the rated current of the plug that can be inserted in the socket-outlet part.

Each socket-outlet part and plug part of an adaptor shall be tested separately.

The plug is inserted into and withdrawn from the socket-outlet part of an adaptor 5 000 times (10 000 strokes), and the plug part of an adaptor is inserted into and withdrawn from the socket-outlet 1 000 times (2 000 strokes), at a rate of:

- 30 strokes per minute for adaptors having a rated current up to and including 16 A and a rated voltage up to and including 250 V;
- 15 strokes per minute for all other adaptors.

Adaptors with incorporated components are tested with these components operating as in normal use.

In addition, after the test the incorporated components shall be operating as in normal use.

Compliance is checked by inspection.

22 Force necessary to withdraw the plug

Replacement:

The construction of adaptors shall allow the easy insertion and withdrawal of the plug, and prevent the plug from working out of the socket-outlet part of the adaptor, in normal use.

For the purpose of this test, resilient earthing contacts, irrespective of the number, are considered as one pole, and non-resilient earthing contacts (for example solid pins used for earthing), irrespective of the number, are considered not to be a pole.

Interlocked adaptors are tested in the unlocked position.

Compliance is checked as follows.

For socket-outlet parts of adaptors, by

- a test to ascertain that the maximum force necessary to withdraw the test plug from the socket-outlet part is not higher than the force specified in Table 16 considering the rating of each socket-outlet type, and
- a test to ascertain that the minimum force necessary to withdraw a single pin gauge from the individual contact assembly is not lower than the force specified in Table 16 considering the rating of each socket-outlet type.

For plug parts of adaptors with resilient earthing contact assemblies, by

- a test to ascertain that the maximum force necessary to withdraw a single pin gauge from the individual resilient earthing contact assembly of the plug part is not higher than the force specified in Table 16 considering the rating of the plug part, and
- a test to ascertain that the minimum force necessary to withdraw a single pin gauge from the individual earthing contact assembly is not lower than the force specified in Table 16 considering the rating of the plug part.

22.1 Verification of the maximum withdrawal force

22.1.1 Test for socket-outlet parts of adaptors

The adaptor is fixed to the mounting plate A of an apparatus as shown in Figure 18, so that the axes of the socket-contacts are vertical and the entry holes for the pins of the plug face downwards.

The test plugs have finely ground pins of hardened steel, having a surface roughness between $0,6 \mu\text{m}$ ($\sqrt{\text{0,6}}$) and $0,8 \mu\text{m}$ ($\sqrt{\text{0,8}}$) over their active length and spaced at the nominal distance, with a tolerance of $\pm 0,05 \text{ mm}$.

The diameter, for round pins, and the distance between contact surfaces, for other types of pins, shall have respectively the maximum specified dimensions, with a tolerance of $^{0}_{-0,01} \text{ mm}$.

The pins are wiped free from grease, before each test, using a cold chemical degreaser.

The test plug with the maximum size pins is inserted into and withdrawn from the socket-outlet part of the adaptor 10 times. It is then inserted again, a carrier E for a principal mass F and a supplementary mass G being attached to it by means of a suitable clamp D. The supplementary mass is such that it exerts a force equal to one-tenth of the maximum withdrawal force shown in Table 16.

The principal mass, together with the supplementary mass, the clamp, the carrier and the plug exert a force equal to the maximum withdrawal force shown in Table 16.

The principal mass is hung on the plug without jolting and the supplementary mass is, if necessary, allowed to fall from a height of 50 mm onto the principal mass.

The plug shall not remain in the socket-outlet part of the adaptor.

The test is repeated for each socket-outlet part.

22.1.2 Test for plug parts of adaptors with resilient earthing contact assemblies

The test pin gauge, illustrated in Figure 19, is applied to the resilient earthing contact assembly, while the plug is held vertically and the gauge is hanging downwards.

The test pin gauge is made of hardened steel, having a surface roughness between $0,6 \mu\text{m}$ ($\sqrt{\text{0,6}}$) and $0,8 \mu\text{m}$ ($\sqrt{\text{0,8}}$) over its active length.

The diameter, for round pins, and the distance between contact surfaces, for other types of pins, shall have respectively the maximum specified dimensions, with a tolerance of $^{0}_{-0,01} \text{ mm}$.

The mass of the gauge shall be such that it exerts a force equal to that specified in Table 16.

The pin is wiped free from grease, before the test, using a cold chemical degreaser.

The test pin with the maximum dimension(s) is inserted into and withdrawn from the earthing contact ten times. It is then inserted again and shall not remain in the contact assembly.

22.2 Verification of the minimum withdrawal force

The test pin gauge, illustrated in Figure 19, is applied to each individual contact with the socket-outlet part or the plug part held in such way that the gauge is hanging downwards.

Shutters, if any, are rendered inoperative so as not to affect the test.

The test pin gauge is made of hardened steel, having a surface roughness between $0,6 \mu\text{m}$ ($\sqrt{0,6}$) and $0,8 \mu\text{m}$ ($\sqrt{0,8}$) over its active length.

The diameter, for round pins, and the distance between contact surfaces, for other types of pins, shall have respectively the minimum specified dimensions, with a tolerance of $^0_{-0,01}$ mm and a length sufficient to make adequate contact with the contact assembly. The force of the gauge shall be equal to that specified in Table 16.

If the socket-outlet part of the adaptor is intended to accept plugs having pins with different nominal dimensions the smallest appropriate one shall be used.

In this case, the rating of the accessory in Table 16 is the rating of the plug with the smallest dimensions for the pins.

The pin is wiped free from grease, before each test, using a cold chemical degreaser.

The test pin gauge is inserted into the contact assembly.

The test pin gauge is applied gently, and care is taken not to knock the assembly when checking the minimum withdrawal force. The gauge shall not fall from the contact assembly within 30 s.

Table 16 – Maximum and minimum withdrawal force for plug and socket-outlet parts of adaptors

Ratings of the relevant part	Number of poles of the adaptor	Withdrawal force N		
		Multi-pin gauge maximum	Single-pin gauge minimum	Single-pin gauge maximum ^a
Up to and including 13 A	2	40	1,5	17
	3	50		
	More than 3	70		
Above 13 A up to and including 16 A	2	50	2,0	25
	3	54		
	More than 3	70		
Above 16 A up to and including 32 A	2	80	3,0	27
	3	80		
	More than 3	100		

^a These withdrawal forces are only for testing the resilient earthing contact assembly of a plug part of the adaptor.

NOTE In the following countries different values apply: MY, SG, UK.

23 Flexible cables and their connection

This clause of Part 1 is applicable except as follows:

23.1 Replacement:

Adaptors with cable outlet and rewirable intermediate adaptors shall be provided with a cable anchorage such that the conductors are relieved from strain, including twisting, where they are connected to the terminals and such that their covering is protected from abrasion.

The sheath, if any, of the flexible cable shall be clamped within the cable anchorage.

Compliance is checked by inspection and by the test of 23.2.

Non-rewirable intermediate adaptors shall be designed in such a way that the cable is maintained in position and the terminations are relieved from strain and twisting.

The sheath, if any, of the flexible cable shall be maintained inside the accessory.

Compliance is checked by the test of 23.2 and 23.4.

23.2 *Replacement in Table 18 of “Rating of plug or portable socket-outlet” with “Rating of adaptor with cable outlet or intermediate adaptor”.*

Replacement of the first paragraph after Table 18:

Adaptors with cable outlet or intermediate adaptors provided with flat tinsel cables are not subjected to the torque test.

23.3 *Replacement of the first paragraph and NOTE:*

Non-rewirable intermediate adaptors intended for use with a flexible cable shall be provided with a flexible cable complying with IEC 60227 or IEC 60245 for external conductors able to supply a current according to the rated characteristics of appliances or an external flexible cable intended for control. The cross-sectional areas of the conductors in relation to the rating of the intermediate adaptors are given in the relevant columns of Table 20.

NOTE Table 20 also specifies the test currents for the test temperature rise and normal operation.

External flexible cables intended for control shall comply with the requirements of 14.103.

Replacement in Table 20 of the column headings “Rewirable portable accessories” by “Adaptors” and “Non-rewirable plugs” by “Non-rewirable intermediate adaptors with flexible cable connection”.

Replacement of the first paragraph after Table 20:

Flexible cables shall have the same number of conductors as there are poles in the adaptor with cable outlet or intermediate adaptor, earthing contacts, if any, being considered as one pole, irrespective of their number. The conductor connected to the earthing contact shall be identified by the colour combination green/yellow.

23.4 *Replacement of the first paragraph:*

Non-rewirable intermediate adaptors with a flexible cable shall be so designed that the flexible cable is protected against excessive bending where it enters the adaptor.

Replacement of the two dashes of the seventh paragraph:

– *plug part of non-rewirable intermediate adaptor: by the pins;*

- *socket-outlet part of non-rewirable intermediate adaptor: at a distance of 4 mm to 5 mm in the direction of the flexible cable, from the engagement face; a test plug having the maximum dimensions shall be inserted in the socket-outlet part during the test.*

24 Mechanical strength

This clause of Part 1 is applicable except as follows:

Replacement of the first and second paragraphs:

Adaptors shall have adequate mechanical strength to withstand the stresses imposed during use.

Compliance is checked by the appropriate tests as indicated below:

- *for adaptors:*
 - *with enclosures, covers or bodies other than elastomeric or thermoplastic material 24.2 and 24.10;*
 - *with enclosures, covers or bodies of elastomeric or thermoplastic material 24.2, 24.4, 24.5 and 24.10;*
- *for pins provided with insulating sleeves in plug parts of adaptors 24.7;*
- *for socket-outlet parts of adaptors provided with shutters 24.8;*
- *for shroud of socket-outlet parts of adaptors 24.19.*

24.2 *Addition at the end of the fourth paragraph:*

For adaptors:

- *50 if the mass of the specimen does not exceed 50 g;*
- *25 if the mass of the specimen exceeds 50 g.*

Replacement of the last dashed item of the sixth paragraph:

- *the pins shall not turn when a torque of 0,4 Nm is applied, first in one direction for 1 min and then in the opposite direction for 1 min. This test is not carried out on adaptors where the rotation of the pins does not impair safety or function.*

Addition at the end:

NOTE 101 The breakage of parts of equipment incorporated in the adaptors is ignored provided the requirements of Clause 10 are met and the functioning of the equipment does not give rise to a dangerous situation.

24.7 *Replacement of the first paragraph:*

Pins of plug parts of adaptors with insulating sleeves are subjected to the following test by means of an apparatus as shown in Figure 28.

24.8 *Replacement of the first paragraph:*

Shuttered socket-outlet parts of adaptors shall have a shutter so designed that it withstands the mechanical force which may be expected in normal use, for example when a pin of a plug is inadvertently forced against the shutter of a socket-outlet entry hole.

24.10 *Replacement of the second paragraph:*

The adaptor is placed on a rigid steel plate provided with holes suitable for the pins of the plug part of an adaptor as shown as an example in Figure 30.

24.19 Replacement of the second paragraph:

The shrouds of socket-outlet parts of adaptors are subjected to a compression test at an ambient temperature of $(25 \pm 5) ^\circ\text{C}$ in an apparatus similar to that shown in Figure 38.

25 Resistance to heat

This clause of Part 1 is applicable.

26 Screws, current-carrying parts and connections

This clause of Part 1 is applicable.

27 Creepage distances, clearances and distances through sealing compound

This clause of Part 1 is applicable except as follows:

27.1

Replacement of the fifth dashed text of item 2 in Table 23:

- external assembly screws, other than screws which are on the engagement face of the adaptor and are isolated from earthing circuit

Replacement of item 3 in Table 23:

- 3) between pins of an adaptor and metal parts connected to them when fully engaged, and a socket-outlet having accessible unearthed metal parts^b, made according to the most unfavourable construction^c

Replacement of item 4 in Table 23:

- 4) between the accessible unearthed metal parts^b of a socket-outlet and a fully-engaged adaptor having pins and metal parts connected to them made according to the most unfavourable construction^c

Replacement of item 5 in Table 23:

- 5) between the live parts of a socket-outlet part of an adaptor (without a plug) and its accessible unearthed metal parts^b

Replacement of the fifth dashed text of item 7 in Table 23:

- external assembly screws, other than screws which are on the engagement face of the adaptor and are isolated from earthing circuit

Replacement of the value “6” by “6^d” in the third dashed text of item 8, in the column mm, in Table 23 in order to apply footnote d to that clearance.

Replacement of the sixth paragraph:

Adaptors are checked when in engagement with a socket-outlet and with and without corresponding plugs fitted.

28 Resistance of insulating material to abnormal heat, to fire and to tracking

This clause of Part 1 is applicable except as follows:

28.1 Replacement of the second paragraph:

Compliance is checked by the test of 28.1.1 and, in addition, for pins of adaptors provided with insulating sleeves, by the test of 28.1.2.

28.1.2 Replacement of the first paragraph:

A specimen with pins provided with insulating sleeves is tested by means of the test apparatus as shown in Figure 40.

29 Resistance to rusting

This clause of Part 1 is applicable.

30 Additional tests on pins provided with insulating sleeves

This clause of Part 1 is applicable.

not for sale www.psqca.com.pk

Annex A
(normative)

**Safety-related routine tests for factory-wired portable accessories
(protection against electric shock and correct polarity)**

This annex of Part 1 is applicable.

not for sale www.psqca.com.pk

Annex B
(normative)

Survey of specimens needed for tests

This annex of Part 1 is not applicable.

not for sale www.psqca.com.pk

Annex C
(informative)

Alternative gripping tests

This annex of Part 1 is applicable.

not for sale www.psqca.com.pk

Annex D (normative) Switches incorporated in portable socket-outlets

This annex of Part 1 is applicable except as follows:.

Replace the title of Annex D:

not for sale www.psqca.com.pk

Annex D
(normative)

Switches incorporated in adaptors

not for sale www.psqca.com.pk

Annex E
(informative)

Changes planned for the future in order to align IEC 60884-1 with the requirements of IEC 60228, IEC 60998 and IEC 60999

This annex of Part 1 is applicable.

Addition:

not for sale www.psqca.com.pk

Annex AA (normative)

Travel adaptors

Annex AA includes specific requirements for travel adaptors as defined in the main part of this document.

For some travel adaptor designs, which allow the connection of a plug to a socket-outlet of a different national system, it may be necessary to deviate from some of the requirements in the main part of this document and in particular to some of the dimensions in the national standard sheets.

Annex AA supplements or modifies the corresponding clauses of the main part of this document.

Where this annex states "addition", "modification" or "replacement", the relevant requirement, test specifications or explanatory matter in the main part shall be adapted accordingly.

1 Scope

This clause of the main part is applicable:

2 Normative references

This clause of the main part is applicable.

3 Definitions

This clause of the main part is applicable.

4 General requirements

This clause of the main part is applicable.

5 General remarks on tests

This clause of the main part is applicable except as follows:

5.4 Addition after the NOTE:

Unless otherwise stated, all tests shall be performed for all possible combinations of plug parts and socket-outlet parts as declared by the manufacturer.

All tests shall also be performed for all possible working positions of movable pins, if any.

For the tests of Clauses 19, 20 and 21 the number of specimens and tests may be reduced considering the dimensions of the plugs to be inserted and their rated current assuring that the most onerous cases are covered for each separate set of contacts, if any.

Where the travel adaptor accepts round and flat plug pins, at least one of each type shall be tested.

6 Ratings

This clause of the main part is applicable except as follows:

6.102 *Replacement:*

6.102 The rated current of the travel adaptor shall be the lowest value of the following:

- the lowest rated current of the plug type(s) of the plug part; or
- the highest rated current of the plug type(s) which can be inserted into the travel adaptors;
or
- the rated current of the incorporated overcurrent protective device, if any.

7 Classification

This clause of the main part is applicable except as follows:

7.2.2 *Delete the dashed text a).*

8 Marking

This clause of the main part is applicable except as follows:

Addition:

8.101 **Additional requirements for travel adaptors**

NOTE In the following country, the instructions for use shall include that travel adaptors shall not be used for charging electrical vehicles: SE.

The manufacturer shall indicate on the travel adaptor and/or in the documentation accompanying the travel adaptor that the travel adaptor is for temporary use only and that it shall not be used permanently.

The manufacturer shall indicate on the travel adaptor and/or in the documentation accompanying the travel adaptor the types of plugs and socket-outlets according to Figure AA.1 and the countries in which it is intended to be used.

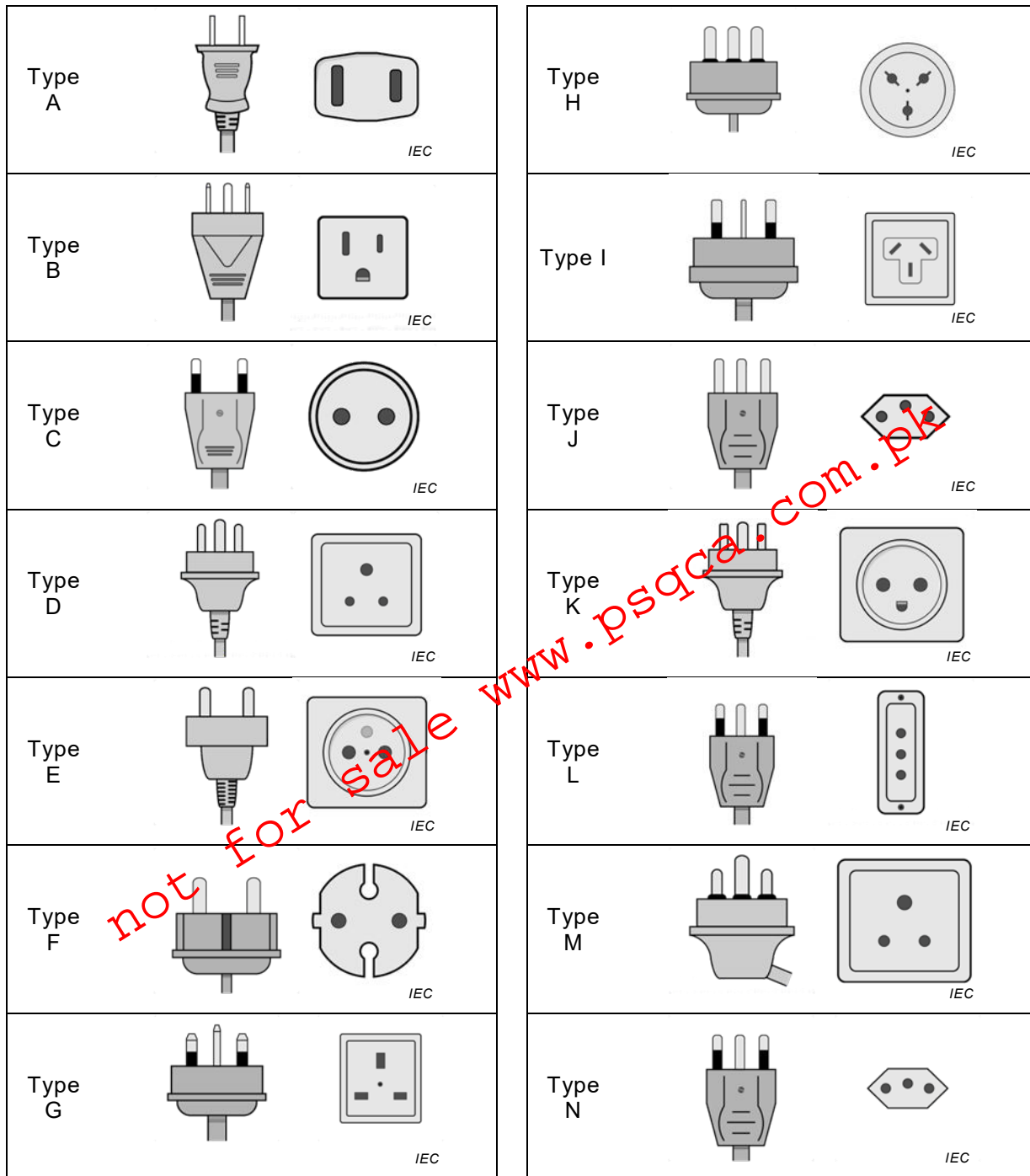

Figure AA.1 – World plug types

Compliance is checked by inspection of the documentation and of the design of the travel adaptor.

9 Checking of dimensions

This clause of the main part is applicable except as follows:

9.1 Replacement of the first paragraph:

For travel adaptors the plug part and the socket-outlet part shall comply with the national specifications and standard sheets of the countries for which the manufacturer declares compatibility.

For travel adaptors allowing the connection of plugs of different national systems or insertion into different national systems the following deviations may be allowed if safety is not impaired:

- overlapping entry holes on the socket-outlet part,
- plugs combining different national standards on the plug part,
- outer body dimensions.

NOTE 1 See also 9.3 for additional information about deviations from the dimensions specified in the standard sheets.

NOTE 2 In the following countries travel adaptors with deviations from the national specifications and standard sheets are allowed: CH, ES, FR, ZA.

NOTE 3 In the following countries restrictions to the overlapping entry holes are applied: AU, CN, DK, IT, MY.

NOTE 4 In the following countries travel adaptors with deviations from the national specifications and standard sheets are not allowed: CA.

9.2 Addition after the first paragraph:

Travel adaptors allowing temporary connection of a plug with a socket-outlet having a higher voltage rating are allowed, provided that the manufacturer gives information for the safe use directly on the travel adaptor, for example “DOES NOT CONVERT VOLTAGE”.

10 Protection against electric shock

This clause of the main part is applicable, except as follows:

10.1 Replacement of the second paragraph and NOTE:

Live parts shall not be accessible when the plug part of a travel adaptor is in partial or complete engagement with a socket-outlet.

NOTE In the following countries this requirement does not apply when the plug part of the travel adaptor is partially engaged: CA, DK, JP, US.

Replacement of the sixth paragraph:

For travel adaptors, the test finger is applied in every possible position when the travel adaptor is in partial or complete engagement with a socket-outlet.

Addition:

NOTE 101 In the following countries the use of a shutter as the only means to prevent single-pole insertion is not allowed: AT, CA, CZ, DE, DK, ES, FI, NL, NO, PT, SE, UK, US.

10.3 Replacement of the first paragraph:

It shall not be possible to make contact between a pin of a plug and a live socket contact of a travel adaptor or between a pin of a travel adaptor and a live socket contact of a socket-outlet whilst any other current carrying pin is accessible.

11 Provision for earthing

This clause of the main part is applicable except as follows:

Addition:

11.101 For earthed configurations, it shall not be possible to engage the current-carrying pins of the travel adaptor in a socket-outlet without the corresponding earth becoming engaged.

Compliance is checked by inspection and electrical test.

The test shall be performed with the travel adaptor pins in all possible positions.

12 Terminals and terminations

This clause of the main part is applicable.

13 Construction of fixed socket-outlets

This clause of the main part is applicable.

14 Construction of travel adaptors

This clause of the main part is applicable except as follows:

14.1 Replacement:

The socket-outlet part of a travel adaptor may have one or more socket-outlet type(s), but it shall accommodate only one plug at a time.

Compliance is checked by inspection.

The socket-outlet part(s) of travel adaptors shall be provided with shutters.

Compliance is checked by inspection.

For travel adaptors comprising several parts, the use of the travel adaptor shall remain safe for all combinations of parts.

NOTE An example of a travel adaptor comprising several parts is one where the socket-outlet part can be attached to several detachable plug parts and vice versa.

Compliance is checked by inspection and applying all the tests to each different combination.

Live parts of any detachable plug part, when not attached to the relevant socket-outlet part of the travel adaptor, shall not be accessible when inserted into the relevant socket-outlet.

Compliance is checked by inspections and, in case of doubt, by applying test probe 13 according to IEC 61032 with a force not exceeding 5 N, in every possible position, with the plug part in full engagement with a socket-outlet. The test probe shall not touch live parts.

The plug part of a travel adaptor may have one or several plug type(s), but only one plug can be electrically connected at a time.

There shall be no electrical connection between different pin combinations, if any, when one of them is ready for use. This shall additionally be tested with the pin combinations (use and unused, if any) in intermediate positions.

Compliance is checked by applying the standard test finger, test probe B of IEC 61032, in every possible position, an electrical indicator with a voltage between 40 V and 50 V being used to show contact with the relevant parts.

14.107 Replacement:

Travel adaptors shall not have any socket-outlet part which permits the insertion of a plug with current rating exceeding 1,25 times the lowest rated current of the plug types(s) of the plug part of the travel adaptor, unless the travel adaptor is provided with an overcurrent protective device rated less than or equal to the rated current of the plug part.

Compliance is checked by inspection.

15 Interlocked socket-outlets

Replacement of the heading of Clause 15 by the following:

15 Interlocked socket-outlet parts of adaptors

This clause of the main part is applicable.

16 Resistance to ageing, protection provided by enclosures, and resistance to humidity

This clause of the main part is applicable except as follows:

16.1 Addition before the last paragraph:

For travel adaptors with movable pins or detachable plug and/or socket-outlet parts, all specimens shall be subjected to a test with 300 cycles of complete movements of the pins which have been selected for the tests of Clause 19, 20 and 21 or of the detachable plug and/or socket-outlet parts.

17 Insulation resistance and electric strength

This clause of the main part is applicable.

18 Operation of earthing contacts

This clause of the main part is applicable.

19 Temperature rise

This clause of the main part is applicable.

20 Breaking capacity

This clause of the main part is applicable except as follows:

Replacement of the paragraph after "Replacement of the ninth paragraph":

The test voltage shall be 1,1 times the rated voltage of the plug part and the test current shall be 1,25 times the current which is the lowest between the rated current of the plug that can be inserted in the socket-outlet part and the rated current of the plug part of the travel adaptor.

Addition:

If more than one type of plug can be engaged into the socket-outlet part, this test shall be performed for the types of plugs on new additional sets of specimens (one set of 3 specimens for each type of plug), chosen according to 5.4, previously submitted to the test of 16.1, and subsequently submitted to the tests of Clause 21.

In addition to the above tests, an additional set of specimens is required to be tested with all types of plugs. Each plug is inserted and withdrawn from the socket-outlet 50 times (100 strokes) divided by the number of plugs which may be inserted in that socket-outlet part. That set of specimens shall also be previously submitted to the test of 16.1, and subsequently submitted to the tests of Clause 21.

21 Normal operation

This clause of the main part is applicable except as follows:

Replacement of the paragraph after "Replacement of the two paragraphs after NOTE 3:"

The specimens are tested at the rated voltage of the plug part, in a circuit with $\cos\phi = 0,8 \pm 0,05$, with an alternating current as follows:

- for travel adaptors without incorporated overcurrent protective device, the test current being the current which is the lowest between the rated current of the plug that can be inserted in the socket-outlet part and the rated current of the plug part of the travel adaptor,*
- for travel adaptors with incorporated overcurrent protective device, the test current being the rated current of the protective device but not higher than the lowest between the rated current of the plug that can be inserted in the socket-outlet part and the rated current of the plug part of the travel adaptor.*

Addition:

For the additional set of specimens which was tested in Clause 20 with all types of plugs, each plug is inserted and withdrawn from the socket-outlet 5 000 times (10 000 strokes) divided by the number of plugs which may be inserted in that socket-outlet part.

22 Force necessary to withdraw the plug

This clause of the main part is applicable.

23 Flexible cables and their connection

This clause of the main part is applicable.

24 Mechanical strength

This clause of the main part is applicable except as follows:

24.2 Addition:

For travel adaptors with movable pins, the test shall be repeated on a new set of specimens for each plug type.

25 Resistance to heat

This clause of the main part is applicable.

26 Screws, current-carrying parts and connections

This clause of the main part is applicable.

27 Creepage distances, clearances and distances through sealing compound

This clause of the main part is applicable.

28 Resistance of insulating material to abnormal heat, to fire and to tracking

This clause of the main part is applicable.

29 Resistance to rusting

This clause of the main part is applicable.

30 Additional tests on pins provided with insulating sleeves

This clause of the main part is applicable.

not for sale www.psqca.com.pk

Annex BB (informative)

Examples of adaptors

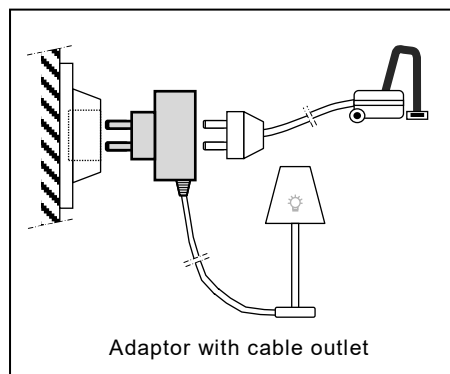
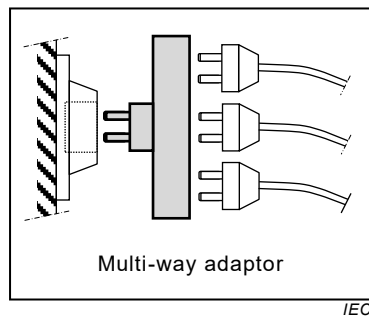
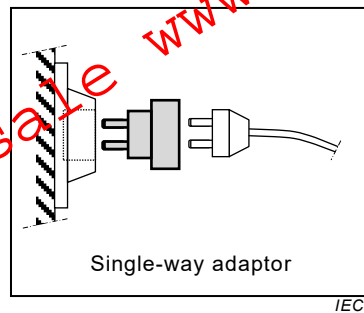
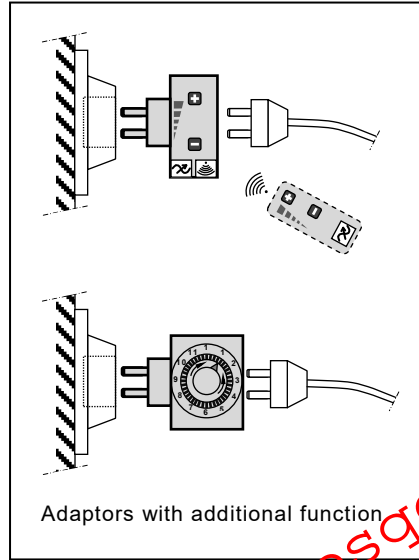

not for sale www.psgca.com.pk

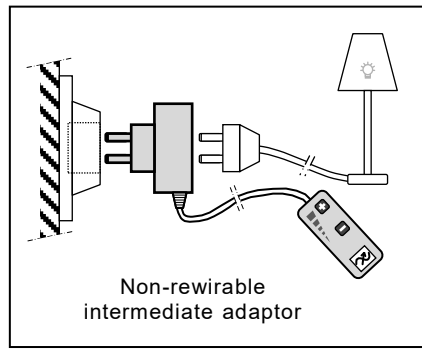

IEC

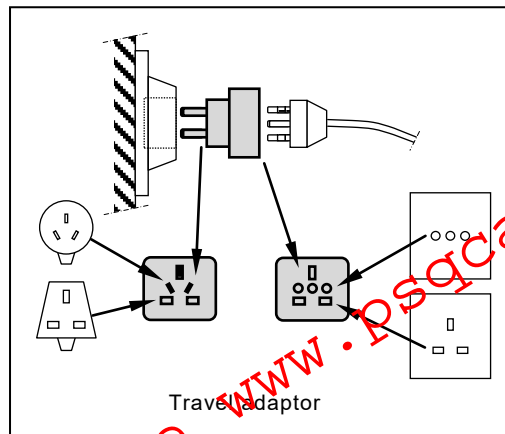

IEC

not for sale www.psgca.com.pk

Bibliography

The Bibliography of part 1 is applicable except as follows:

Addition:

IEC 60038, *IEC standard voltages*

IEC TR 60083, *Plugs and socket-outlets for domestic and similar general use standardized in member countries of IEC*

EN 50075, *Flat non-rewirable two-pole plugs, 2,5 A 250 V, with cord, for the connection of class II-equipment for household and similar purposes*

not for sale www.psqca.com.pk